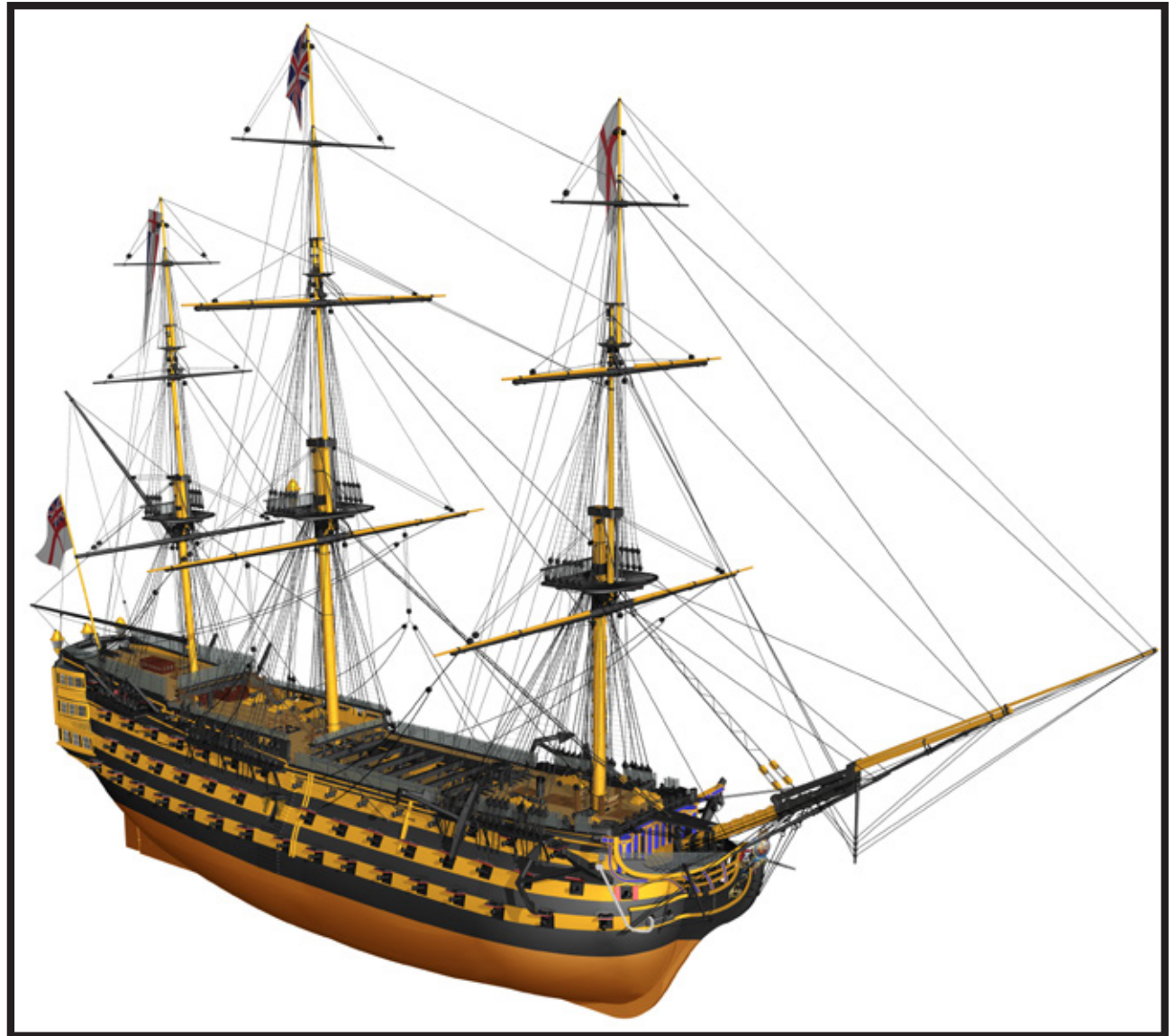


HMS Victory “498” ***



BUILDING INSTRUCTION

This model is Copyright protected.
All Copyrights to the designs of this
version of the HMS Victory belongs to
Billing Boats Denmark Aps



DK

HMS Victory blev søsat i 1765 fra Chatham Skibsværft, og hun blev indsat i flådens tal i 1778. Hun tjente den engelske flåde i 34 år, og deltog i det berømte "Slaget ved Trafalgar" i 1805. I 1812 blev hun pensioneret fra aktiv tjeneste, og kastede anker i Portsmouth Havn. Her lå hun i de næste 110 år, hvor udførte en række praktiske opgaver samt ceremonielle tjenester. Af frygt for at hun måske ikke vil overleve de kommende år, blev hun i 1922 flyttet til Portsmouths Royal Navy Dockyard (Flådens Skibsværft) og placeret i tørdok nummer 2. HMS Victory er det eneste overlevende skib, der kan dokumentere de mange kompetencer, som de engelske skibsdesignere og skibs-byggere havde i midten af det 18. århundrede.

GB

HMS Victory was launched in 1765 at Chatham Dockyard and was commissioned in 1778. She continued in active service for the next 34 years which included her most famous moment "the Battle of Trafalgar" in 1805. In 1812 the Victory was retired from frontline duty and anchored in Portsmouth Harbour, on the south coast of England. For the next 110 years the Victory remained at her moorings in Portsmouth Harbour fulfilling a combination of practical and ceremonial roles. In 1922, amid fears for her continued survival, the Victory was moved into Portsmouth's Royal Naval Dockyard and placed in No2 Dry Dock. Her Majesty's Ship Victory is the only surviving

naval warship that represents the skill of naval dockyard shipwrights, ship designers and the industrial ability of Britain during the mid 18th century.

D

"Die HMS Victory lief im Jahre 1765 in der Chatham Schiffswerft vom Stapel, ihren Dienst in der Marine begann sie im Jahre 1778. 34 Jahre lang segelte sie als Kriegsschiff unter der Fahne der Flotte und nahm an der berühmten Schlacht von Trafalgar 1805 teil. Im Jahre 1812 schied das Schiff aus dem Militärdienst aus und ging im Hafen von Portsmouth vor Anker. Hier war die HMS Victory fast 110 Jahre lang zu Hause, führte eine Reihe praktischer Aufgaben aus und diente als Kulisse für verschiedene Zeremonien. Als zu befürchten war, dass das Schiff die kommenden Jahre vielleicht nicht mehr überstehen würde, verfrachtete man die alte Dame im Jahre 1922 zur Portsmouths Royal Navy Dockyard (Schiffswerft der Marine) in das Trockendock Nummer 2. Die HMS Victory ist das einzige noch existierende Schiff, anhand dessen sich die große Kompetenz-Palette englischer Schiffsdesigner und -bauer des 18. Jahrhunderts dokumentieren lässt."

F

"Le HMS Victory fut mis à l'eau en 1765 à partir du chantier naval de Chatham pour ensuite

faire partie de la flotte en 1778. Il servait la flotte anglaise pendant 34 ans et participa à la célèbre bataille de Trafalgar en 1805. Le navire fut retiré du service actif en 1812 et l'ancre jetée au port de Portsmouth. Le navire y reposait pendant les 110 années suivantes pendant lesquelles une série de tâches pratiques et des services cérémoniels furent réalisés. De crainte que le navire ne survive les années à venir, il fut déplacé au " Portsmouth Royal Navy Dockyard " (le chantier naval de la flotte) à la cale sèche numéro 2. Le HMS Victory est le seul navire survivant qui puisse documenter les nombreuses compétences que possédaient les dessinateurs et constructeurs de navires anglais au milieu du 18e siècle."

NL

De HMS Victory werd in 1765 op de scheepswerf van Chatham te water gelaten en in 1778 ingezet door de marine. Ze diende gedurende 34 jaar de Britse vloot en speelde een belangrijke rol in de beroemde zeeslag bij Trafalgar in 1805. In 1812 werd ze uit actieve dienst gesteld en ging ze in Portsmouth voor anker waar ze vervolgens ruim honderd jaar praktische taken en ceremoniële diensten uitvoerde. Uit vrees dat ze het niet zou overleven werd ze in 1922 naar droogdok nummer 2 van de Portsmouths Royal Navy Dockyard (de scheepswerf van de marine) versleept. De HMS Victory is het enige in dienst zijnde schip dat nog getuigt van de vaardigheden van de Britse scheepsontwerpers en schepenbouwers in het midden van de 19e eeuw.

E

El HMS Victory fue botado a mar en 1765 desde el astillero Chatham y se incorporó a la flota en 1778. Prestó sus servicios en la flota inglesa durante 34 años y participó en la famosa "Batalla de Trafalgar" en 1805. En 1812 se jubiló del servicio activo y fue fondeado en puerto Portsmouth. Allí estuvo durante los próximos 110 años, donde desempeñó una serie de ejercicios prácticos y actos ceremoniales. Por temor a que quizás no sobreviviera los años siguientes, fue trasladado en 1922 a la Royal Navy Dockyard en Portsmouth (Astillero naval), y fondeado en el Dique 2. El HMS Victory es el único buque sobreviviente que muestra pruebas de las muchas habilidades que los diseñadores y constructores de buques ingleses poseían a mediados del siglo XVIII.

KØL OG SPANTER

Først sættes spanterne helt vinkelret på kølen. Dette gøres nemmest på en byggebedding (Billing Boats #397). Derefter monteres dæk og evt. skot. Når dette er tørt, slibes spanterne i smig, derved opnås en større limflade. Samtidig bevirker dette, at beklædningslisterne ligger langt pænere. Beklædningen af skroget kan gøres på mange måder. Vi vælger her at gøre det som følgende: Start med at lægge første liste så denne følger dækkets overkant. Der limes på hver spant samt listens underkant, og listen sættes fast med nåle. Nu kan du beklæde skroget nedefter skiftene fra side til side for at undgå skævheder pga. listernes træk. Hver enkelt liste skal skæres/slibes konisk så den følger skrogets facon, når den med et let tryk sættes på plads. Pres ikke listen på plads. Skal skroget bejdses, tør da overflødig lim væk med en fugtig klud. Når du er nået til kølen, starter du igen fra dækket og beklæder opefter. Derefter grovpudses skroget og efterlimes, hvis dette er nødvendigt. Man kan med stor fordel også påføre en primer (hvid lim tilsat en smule vand), mens man sliber skroget, da dette vil lukke små huller og revner. Dette må ikke gøres, hvis skroget skal bejdses, da lim ikke optager bejdse. Når det er tørt, kan skroget finpudses og fenderlister, rælingslister mm. påsættes.

KEEL AND FRAMES

Position the frames at right angles to the keel. The use of a building slip simplifies this task (Billing Boats #397). Next mount the deck and bulkhead. When dry, sand the frames to taper. This ensures both a larger gluing surface and a better positioning of the planking strips. Planking the hull can be done in a number of ways. Here we have chosen to start by applying the

first strip so that it follows the upper edge of the deck. Apply glue to each frame and the upper edge of the strip, and hold the strip in place with pins until dry. Proceed planking the hull downwards, shifting from side to side in order to avoid any disalignment as the strips are applied. Each strip should be cut or sanded conically to fit the shape of the hull when gently placed on the frame. Do not force the strip into position. If the hull is to be stained, remove any excess cement with a damp cloth. When you have planked downwards to the keel, begin again from the deck and upwards. Sand the entire hull roughly, and re-glue where necessary. It can also be a good idea to apply a primer (white cement slightly diluted with water) while sanding the hull, as this will close off any small holes or cracks. This is not to be done if the hull is to be stained, as glue is stain-resistant. When dry, sand the hull again very carefully. Fender and railing strips, etc. can then be mounted.

KIEL UND SPANTEN

Als erstes werden die Spanten winkeltrecht auf dem Kiel angebracht. Für diese Arbeit ist eine Bauhelling von Vorteil (Billing Boats #397). Danach bringen Sie die Decks und eventuelle Schotten an. Nachdem die Leimungen ausgehärtet sind werden die Spanten in Facon (Schmiege) geschliffen, dadurch erhalten Sie eine genaue Rumpfform und eine größere Leimfläche. Die Beplankung des Rumpfes kann auf verschiedene Methoden vorgenommen werden. Wir schlagen folgende Methode vor: Beginnen Sie mit der ersten Leiste in Höhe Decksoberkante. Streichen Sie die Spantabschnitte die die Leisten aufnehmen gut mit Leim ein, das gleiche gilt für die Stoßkanten der Beplankungsleisten. Überschüssiger Leim sofort mit einem feuchten

Lappen abwischen. Niemals mit Leim sparen. Die Beplankungsleisten bis zum trocknen des Leimes mit Stecknadeln, kleinen Nägel oder Wäscheklammern festheften. Beplanken Sie nun nach unten, und zwar immer eine Leiste auf der einen, sowie auf der anderen Seite, dadurch wird ein Verziehen des Rumpfes vermieden. Außerdem müssen die Leisten konisch geschliffen oder geschnitten werden, da die Fläche des Hauptspantes größer als an den Bug- und Heckspanten. Niemals eine Leiste unter Spannung festsetzen. Danach das Schanzkleid beplanken, also nach oben. Jetzt kann der Rumpf grob vorgeschliffen und gespachtelt werden. Nachdem der Rumpf fertig geschliffen ist können Fenderleisten, Relingsleisten u.s.w. angebracht werden.

QUILLE ET MEMBRURES

Positionner les couples à angle droit par rapport à la quille. L'utilisation d'un bâti de montage simplifie ce travail (Billing Boats #397). Ensuite, installer le pont et les cloisons. Après séchage, poncer les couples aux différentes inclinaisons. Ceci donnera une plus grande surface de collage et un meilleur positionnement des baguettes de coffrage. Le coffrage de la coque peut être réalisé de différentes facons. Ici nous avons choisi de commencer en appliquant la première baguette de manière qu'elle suive le bord supérieur du pont. Mettre de la colle sur chaque couple et sur le bord supérieur de chaque baguette. Maintenir les baguettes en place jusqu'au séchage complet avec des épingles. Continuer à coffrer la coque vers le bas en passant d'un côté à l'autre pour éviter de déformer la coque. Chaque baguette doit être coupée, poncée coniquement pour respecter les formes de la coque lorsqu'elle est mise en

position sur les couples. Les baguettes doivent prendre place sans forcer. Si la coque doit être vernie, il faut d'abord retirer tous les excédents de colle. Lorsque la coque a été coffrée jusqu'à la quille, recommencer à partir du pont vers le haut. Poncer soigneusement toute la coque et remettre de la colle aux endroits qui en ont besoin. On peut également diluer de la colle blanche dans de l'eau et en passer sur toute la surface de la coque, ce qui aura pour effet de renforcer les collages et de bucher les petits orifices. Mais ceci ne doit pas être effectué dans le cas d'une coque vernie, la colle deviendrait apparente et empêcherait le vernis de sécher. Après séchage de la colle, poncer à nouveau la coque. Les défenses, les balustades, etc... peuvent être montées.

KIEL EN SPANTEN

Zorg er altijd voor dat de spanten haaks op kiel staan! Het gebruik van een bouwhelling (Billing Boats #397) vereenvoudigt deze taak. Daarna dekken en schotten aanbrengen. Als de lijm goed droog is, moeten de spanten in het verloop van de romp gevijld en geschuurd worden. Hierdoor verkrijgt men een groter lijmvlak voor de huidlatten en voorkomt men het ontstaan van lelijke bulten in de romp, die er later niet meer uit te schuren zijn. Er zijn verschillende manieren om een romp te bekleden. Wij hebben ervoor gekozen om eerst vanaf het dek naar beneden te werken en daarna vanaf het dek naar boven. Begin met het aanbrengen van een huidlat op de spanten met de bovenrand van de lat gelijk met de bovenkant van het dek. Zet deze lat op de spanten vast met glaskopspelden, nog niet lijmen. Zet daarna de volgende lat met een speld vast op de middelste spant en druk hem naar voor en naar achter te-

gen de spanten. Als deze lat de bovenliggende lat ergens overlapt, dit dan met een potlood aftekenen op de onderliggende lat. Hierna beide latten verwijderen en het afgetekende gedeelte op de eerste lat verwijderen (dit heet verjongen). Nú pas de eerste lat vastlijmen en met spelden vastzetten tot de lijm goed droog is. De latten worden tegen de spanten en tegen elkaar gelijmd. Deze procedure verder volgen tot de romp dicht is. Het dichtmaken van de romp moet om en om gebeuren, d.w.z. eerst een lat links, dan een lat rechts, dan weer een links enz., dit om het kromtrekken van de romp te voorkomen. Latten die sterk gebogen moeten worden bij voorof achtersteven, kunnen het best in de stoom van een fluitketel gehouden worden tot ze soepel gebogen kunnen worden. Daarna op de romp aanbrengen, met spelden vastzetten, in vorm laten drogen en vastlijmen. Als de onderkant van de romp dicht is, de romp vanaf het dek naar de toppen van de spanten dichtmaken. Door het volgen van deze methode is het gebruiken van spijkertjes overbodig, wat als voordeel heeft dat ze later niet kunnen gaan roesten. Gebruikt U tóch spijkertjes, dan moeten ze bij een varend model goed doorgeslagen worden, waarna de gaatjes met plammuur gedicht moeten worden. Als de romp helemaal dicht is kan hij glad geschuurd worden, waarna eventuele berghouten (stootranden) en potdeksels (afdeklatten op bovenste huidlat) aangebracht kunnen worden. Indien de romp gebeitst moet worden, dient overtollige lijm direct met een vochtige doek verwijderd te worden, daar opgedroogde lijm geen beits opneemt.

QUILLA Y CUADERNAS

Primero monte las cuadernas perpendicularmente en la quilla. Esto se hace más fácilmente

en una basada de construcción (Billing Boats #397). Luego monte la cubierta y eventualmente mamparos. Una vez seco, puede achaflanar las cuadernas para obtener una superficie de encolado más grande. Al mismo tiempo los listones de forro reposan más naturalmente. Se puede efectuar el forro del casco de muchas maneras. Nosotros preferimos hacerlo de la manera siguiente: Coloque el primer listón de manera tal que siga el canto superior de la cubierta. Aplique cola a todas las cuadernas y al canto inferior del listón antes de fijar el listón con agujas. Ahora puede proceder con el revestimiento del casco hacia abajo, cambiando de un lado a otro para evitar torciones del casco como consecuencia de la tracción de los listones. Corte o esmerile cada listón cónicamente, de manera tal que siga la forma del casco al montarlo aplicando una presión ligera. No aplique demasiada presión. En el caso de que desee aplicar mordiente al casco debe remover todo exceso de cola con un trapo mojado. Cuando llegue a la quilla puede empezar de nuevo desde la cubierta hacia arriba. Luego esmerile el casco gruesamente y aplique la cola adicional necesaria. Puede ser una ventaja aplicar una imprimación (cola blanca con un poco de agua) al esmerilar el casco, ya que esto cierra las pequeñas aberturas y grietas. No debe hacer esto en el caso de que desee aplicar mordiente, ya que la cola no absorbe el mordiente. Una vez seco, puede proceder al esmerilado fino del casco y luego al montaje de los listones de defensa, de barandilla, etc.

DÆK

Et dæk kan bearbejdes på flere måder afhængig af, hvor detaljeret du ønsker modellen skal være. Du kan nøjes med at lakere dækket og bruge det, som det er. Du kan også efter lakeringen fordybe alle stregerne på langs med en spids blyant for at markere dæksplankerne. Du kan også lime tynde lister i bredden som angivet nederst. Imellem alle listerne kan du så presse tynd rigningstråd, som skal markere kalfatringen. Derefter lakeres eller males dækket. Kahytter, skylights, nedgange m.m. bør samles og males, før disse anbringes på modellen. Da det gi'r det bedste resultat, og gør det væsentlig nemmere at komme til overalt. Desuden bør alle plastfittings vaskes af med alm. Opvaskemiddel, før disse bliver malet for at fjerne en eventuel fedtet overflade. Ved bukning af lister kan man evt. fugte listen og bukke den over et stearinlys. Alternativt kan du blødgøre listerne i 50% koldt vand og 50% 3-dobbelt salmiakspiritus i et par timer, og skylle dem i koldt vand efter denne procedure. Dette gør at listerne kan bøjes meget let. Sørg for en god udluftning, da lugten fra salmiakspiritussen er meget stærk.

DECK

You can work with the deck in a variety of ways, depending on how detailed you wish your model to be. You can varnish the deck and use as it is. Alternatively, you can varnish the deck and use a sharp pencil to deepen the lines, thereby indicating deck planks. You can also glue thin strips on the deck and press thin rigging thread between the strips, thereby simulating caulking. The varnish or paint the deck. For the best

results, assemble and paint cabin skylights, companionways, etc. before positioning these on the model. It is a good idea to wash all plastic fittings with detergent before painting. This removes any grease from the surface. Bending strips to shape can be made easier by moistening the strip and bending it over a candle flame. You can alternatively soak the strips for a couple of hours in 50% cold water and 50% household ammonia, and rinse in plain water after this procedure. This will make the strips bend easier. Please be careful to soak the strips where you have lots of aircondition, due to the smell of the ammonia.

DECK.

Das Deck zugestalten möchten wir gerne Ihnen überlassen, doch nicht ohne ein paar Tips an Sie weiterzugeben. Sie können das Deck lassen wie es ist, und nur lackieren. Sie können aber auch Linien mit einem harten Bleistift nachziehen, Sie erhalten dadurch eine kleine Vertiefung die wie Plankengänge aussieht. Das beste Ergebnis erzielen Sie, indem Sie dünne Leisten auf das Deck leimen. (In diesem Baukasten bereits enthalten). Zwischen die Leisten können Sie nun schwarzes Nähgarn legen, dadurch erhalten Sie eine täuschend Echte Kalfaterung. Danach das Deck lackieren. Bemalen Sie die fertig zusammengebauten Deckaufbauten vor dem plazieren an Deck. Es ist empfehlenswert den Plastik-Spritzling vor Gebrauch mit Abwaschmittel von Fett zureinigen. Leisten können Sie biegen indem Sie diese etwas befeuchten, oder über der Flamme einer Kerze erhitzen.

PONT

Le pont pourra être réalisé de différentes facons suivant l'aspect final que l'on veut donner au modèle. On pourra simplement le vernir, ou alors après l'avoir verni tracer au feutre ou à l'encre de chine les lignes en faisant apparaître les baguettes de coffrage, on peut également utiliser de très fines baguettes pour coffrer le pont, c'est de cette dernière facon que l'on obtiendra le plus grand réalisme. Le pont sera ensuite verni ou peint. Pour obtenir un meilleur résultat, il est recommandé d'assembler et de peindre les cabines et claire-voies séparément et de les installer ensuite sur le modèle. Il est recommandé de nettoyer toutes les pièces d'accastillage en plastique avec un détergent avant de les peindre. Ceci afin d'éviter d'enlever toute trace de graisse qui empêcherait l'adhésion de la peinture. Ai cas ou certaines baguettes devraient être cintrées, il est recommandé de les mettre dans l'eau et ensuite de les sécher sous forme à la chaleur.

DEK

Het dek kan, afhankelijk van Uw eigen voorkeur, op verschillende manieren afgewerkt worden. De eenvoudigste methode is om met een hard, scherp potlood de deknaden na te trekken en het dek met lak, vernis of beits te verven. Mooier is het om het dek met dunne latjes te bekleden en tussen de latjes dun garen aan te brengen om breeuwnaden te simuleren. (Fig.1). Dekhuizen, bovenlichten e.d. kunnen het beste van te voren in hun geheel samengesteld en gelakt worden; daarna pas op het dek aanbrengen. Het is een goed idee om alle plastic onderdelen vóór het lakken even in afwasmiddel schoon te maken; dit verwijderd

de vettige laag die er tijdens het productie-proces op kan komen.

CUBIERTA

La cubierta puede trabajarse de varios modos, según el grado de precisión que desea para su modelo. Puede conformarse tan sólo con barnizarla y utilizarla tal como está. Puede también, una vez barnizada, profundizar todo el largo de las líneas con un lápiz afilado para marcar los tablones de cubierta. También puede encolar listones delgados a lo ancho entre las líneas marcadas sobre la cubierta. Entre cada uno de los listones puede colocar a presión hilo de aparejo, que marcará el calafateado. Luego se procede a barnizar o pintar la cubierta. Las lumbreras de los camarotes, las bajadas, etc. deben reunirse y pintarse antes de su colocación en el modelo, ya que así se obtiene un mejor resultado y todo resulta más sencillo. Además se debe lavar todos los herrajes de plástico con detergente común antes de pintarlos, para eliminar cualquier superficie engrasada. Para el plegado de listones es posible humedecer el listón y plegarlo sobre una vela de estearina.

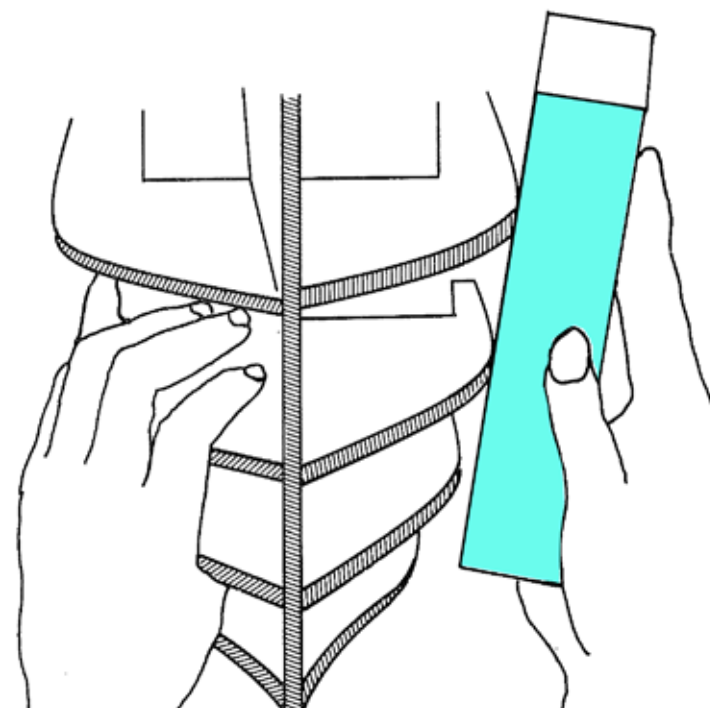
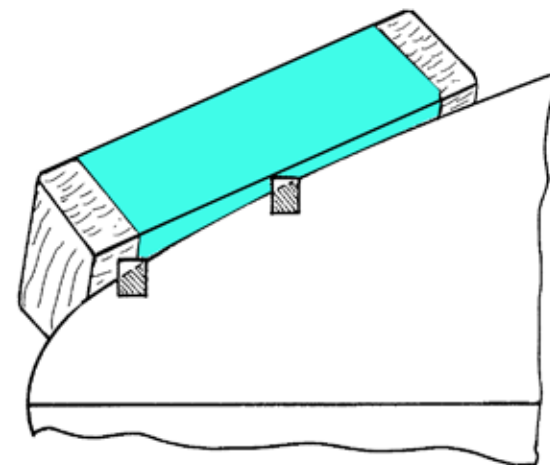


Table contents for "HMS Victory" Art. No. 498

Pcs.	No.	Dimension	Material	DK	GB	D	F
1	1	5mm	3238L - 3	Køl	Keel	Kiel	Quille
1	2	5mm	3238L - 4	Køl	Keel	Kiel	Quille
1	3	5mm	3238L - 3	Køl	Keel	Kiel	Quille
1	4	5mm	3238L - 3	Spant	Frame	Spant	Couple
1	5	5mm	3238L - 2	Spant	Frame	Spant	Couple
1	6	5mm	3238L - 3	Spant	Frame	Spant	Couple
1	7	5mm	3238L - 2	Spant	Frame	Spant	Couple
1	8	5mm	3238L - 3	Støttespant	Support frame	Hilfspant	Pièce d'appui
1	9	5mm	3238L - 1	Spant	Frame	Spant	Couple
1	10	5mm	3238L - 1	Spant	Frame	Spant	Couple
1	11	5mm	3238L - 1	Spant	Frame	Spant	Couple
1	12	5mm	3238L - 1	Spant	Frame	Spant	Couple
1	13	5mm	3238L - 1	Spant	Frame	Spant	Couple
1	14	5mm	3238L - 3	Støttespant	Support frame	Hilfspant	Pièce d'appui
2	15	5mm	3238L - 2	Støttespant	Support frame	Hilfspant	Pièce d'appui
1	16	5mm	3238L - 3	Spant	Frame	Spant	Couple
1	17	5mm	3238L - 2	Spant	Frame	Spant	Couple
1	18	5mm	3238L - 2	Støttespant	Support frame	Hilfspant	Pièce d'appui
1	19	5mm	3238L - 2	Støttespant	Support frame	Hilfspant	Pièce d'appui
1	20	5mm	3238L - 3	Støttespant	Support frame	Hilfspant	Pièce d'appui
1	21	5mm	3238L - 2	Spant	Frame	Spant	Couple
1	22	5mm	3238L - 2	Spant	Frame	Spant	Couple
1	23	5mm	3238L - 2	Støttespant	Support frame	Hilfspant	Pièce d'appui
2	24	5mm	3238L - 2	Støttespant	Support frame	Hilfspant	Pièce d'appui
2	25	5mm	3238L - 2	Stolpe	Posts	Stütze	Socle
2	26	5mm	3238L - 3	Kranbjælke	Crane former	Kranbalken	Traverses de Grue
2	27	5mm	3238L - 1	Bov, træ	Bow timber	Bug Holz	bois Beau
2	28	5mm	3238L - 1	Konsol	Bracket	Halter	Console
2	29	5mm	3238L - 3	Ræling	Rail	Reling	Gouvernail
4	30	5mm	3238L - 1	Stolpe	Posts	Stütze	Socle
2	31	5mm	3238L - 3	Ræling	Rail	Reling	Gouvernail

2	32	5mm	3238L - 3	Mastbeslag	Mast fittings	Mastbeschlag	Garniture de mât
1	33	5mm	3238L - 3	Mastbeslag	Mast fittings	Mastbeschlag	Garniture de mât
6	34	5mm	3238L - 3	Støttebjælke	Support former	Stützbalken	Support Traverses
1	35	5mm	3238L - 2	(Smides væk efter brug)	(Disposal part)	(Entsorgung Teil)	(Disposition une partie)
4	36	5mm	3238L - 3	Indgang	Entrance	Eingang	Entrée
2	37	5mm	3238L - 3	Ræling	Rail	Reling	Gouvernail
1	38	5mm	3238L - 3	Bedding	Slip	Helling	Cale de construction
1	39A	5mm	3238L - 2	Bedding	Slip	Helling	Cale de construction
1	39B	5mm	3238L - 2	Bedding	Slip	Helling	Cale de construction
1	40	5mm	3238L - 3	Bedding	Slip	Helling	Cale de construction
1	41	5mm	3238L - 3	Bjælkebugt	Former	Balkbögen	Traverses
2	42	5mm	3238L - 3	Toilet	Toilet	Toilette	Toilette
8	42A	5mm	3238L - 3	Konsol	Bracket	Halter	Console
2	42B	5mm	3238L - 3	Konsol	Bracket	Halter	Console
2	43	3mm	3241L	Faconstykker	Formed piece	Formteil	Pièce formée
2	44	3mm	3241L	Stolpe	Posts	Stütze	Socle
1	45	3mm	3241L	For bovspryd	For bowsprit	Für Bugsprit	Pour beaupré
1	46	3mm	3241L	For bovspryd	For bowsprit	Für Bugsprit	Pour beaupré
1	47	3mm	3241L	Skot	Bulkhead	Schott	Cloison
2	48	3mm	3241L	Klyds	Fairlead	Verhölklüse	Chaumard
2	49	3mm	3241L	Kanonkugle, opbevaring	Cannonball, storage	Kanonenkugeln, Lagerung	Boulet de canon, stockage
2	50	3mm	3241L	Knæ	Knee	Knie	Genou
2	51	3mm	3241L	Knæ	Knee	Knie	Genou
2	52	3mm	3241L	Kanon	Canon	Geschütze	Canon
2	53	3mm	3241L	Kanon	Canon	Geschütze	Canon
2	54	3mm	3241L	Kanon	Canon	Geschütze	Canon
1	55	Ø3x15mm	Wood	Stolpe	Posts	Stütze	Socle
2	56	3mm	3241L	Stolpe	Posts	Stütze	Socle
4	57	3mm	3241L	Ræling	Rail	Reling	Gouvernail
2	58	3mm	3241L	Klokketårn	Belfry	Glockenturm	Clocher
2	59	3mm	3241L	Klokketårn	Belfry	Glockenturm	Clocher
2	60	3mm	3241L	Klokketårn	Belfry	Glockenturm	Clocher
1	61	3mm	3241L	Bjælkebugt	Former	Balkbögen	Traverses
2	62	3mm	3241L	Støttebjælke	Support former	Stützbalken	Support Traverses

1	63	3mm	3241L	Bjælkebugt	Former	Balkbögen	Traverses
20	64	3mm	3241L	Stolpe	Posts	Stütze	Socle
2	65	3mm	3241L	Ræling	Rail	Reling	Gouvernail
2	66	3mm	3241L	Stolpe	Posts	Stütze	Socle
4	67	3mm	3241L	Indgang	Entrance	Eingang	Entrée
2	68	3mm	3241L	Konsol	Bracket	Halter	Console
2	69	3mm	3241L	Konsol	Bracket	Halter	Console
2	70	3mm	3241L	Ræling	Rail	Reling	Gouvernail
1	71	3mm	3241L	Mastfod	Maststep	Mastfuss	Pommes de mat
2	72	3mm	3241L	Stolpe	Posts	Stütze	Socle
1	73	3mm	3241L	Støtte til bom	Boom saddle	Boom Sattel	selle Boom
4	74	3mm	3241L	Bomgaffel	Boom fork	Boom Gabel	Fourche Boom
2	75	3mm	3241L	For redningsbåd	For lifeboat	Für Rettungsboot	Pour chaloupe pont
2	76	3mm	3241L	For redningsbåd	For lifeboat	Für Rettungsboot	Pour chaloupe pont
2	77	3mm	3241L	Klyds	Fairlead	Verhölklüse	Chaumard
2	78	3mm	3241L	Signal-flagreol	Signal flag storage	Signal Flagge Lagerung	stockage drapeau de signalisation
2	79	3mm	3241L	Bjælkebugt	Former	Balkbögen	Traverses
2	80	3mm	3241L	Bjælkebugt	Former	Balkbögen	Traverses
2	81	3mm	3241L	Hjælpestykker	Auxiliary pieces	Hilfsstücke	Pièce annexes
1	82	3mm	3241L	Hjælpestykker	Auxiliary pieces	Hilfsstücke	Pièce annexes
1	83	3mm	3241L	Hjælpestykker	Auxiliary pieces	Hilfsstücke	Pièce annexes
1	84	3mm	3241L	Hjælpestykker	Auxiliary pieces	Hilfsstücke	Pièce annexes
2	85	3mm	3241L	Mærs	Top	Mars	Hune
2	86	2mm	3241L	Liste	Strip	Leiste	Baguette
2	87	3mm	3241L	Mærs	Top	Mars	Hune
2	88	3mm	3241L	Mærs	Top	Mars	Hune
2	89	3mm	3241L	Mærs	Top	Mars	Hune
2	90	3mm	3241L	Mærs	Top	Mars	Hune
2	91	3mm	3241L	Mærs	Top	Mars	Hune
1	92	3mm	3241L	Mærs	Top	Mars	Hune
1	93	3mm	3241L	Mærs	Top	Mars	Hune
1	94	3mm	3241L	Mærs	Top	Mars	Hune
2	95	3mm	3241L	Hjælpestykker	Auxiliary pieces	Hilfsstücke	Pièce annexes
1	96	2mm	3240L-2	For bovspryd	For bowsprit	Für Bugsprit	Pour beaupré

2	97	2mm	3240L-3	For bovspryd	For bowsprit	Für Bugsprit	Pour beaupré
2	98	2mm	3240L-1	Hjælpestykker	Auxiliary pieces	Hilfsstücke	Pièce annexes
2	99	2mm	3240L-2	Klydsbræt	Fairleadboard	Klüsenbretter	Cahumard de cadènes
1	100	3mm	3241L	Spant	Frame	Spant	Couple
1	101	3mm	3241L	Spant	Frame	Spant	Couple
1	102	3mm	3241L	Spant	Frame	Spant	Couple
1	103	3mm	3241L	Spant	Frame	Spant	Couple
1	104	2mm	3240L-2	Spant	Frame	Spant	Couple
1	105	2mm	3240L-2	Gangbro	Gangway	Laufplanken	Passavant
2	106	2mm	3240L-3	Bov, træ	Bow timber	Bug Holz	bois Beau
2	107	2mm	3240L-2	Ornament	Ornament	Ornamente	Ornament
6	108	2mm	3240L-3	Hjælpestykker	Auxiliary pieces	Hilfsstücke	Pièce annexes
1	109	2mm	3240L-3	Ræling	Rail	Reling	Gouvernail
1	110	2mm	3240L-3	Ræling	Rail	Reling	Gouvernail
2	111	2mm	3240L-3	Ræling	Rail	Reling	Gouvernail
1	112	2mm	3240L-3	Bjælkebugt	Former	Balkbögen	Traverses
2	113	2mm	3240L-2	Kofilnaglebænk	Belaying pin bench	Belegnägelbank	Ratelier de cordage
2	114	2mm	3240L-2	Ræling	Rail	Reling	Gouvernail
2	115	2mm	3240L-2	Ræling	Rail	Reling	Gouvernail
1	116	2mm	3240L-1	Dæk	Deck	Deck	Pont
2	117	2mm	3240L-3	Røstbrædt	Chainboard	Rüstbrett	Cadènes de grand mat
8	118	2mm	3240L-2	Rælingsstøtter	Rail stanchions	Relingsstützen	Chandeliers
1	119	2mm	3240L-3	Liste	Strip	Leiste	Baguette
2	120	2mm	3240L-2	Ræling	Rail	Reling	Gouvernail
4	121	2mm	3240L-2	Ræling	Rail	Reling	Gouvernail
1	122	2mm	3240L-3	Klokketårn	Belfry	Glockenturm	Clocher
1	123	2mm	3240L-3	Klokketårn	Belfry	Glockenturm	Clocher
8	124	2mm	3240L-2	Anker	Anchor	Anker	Ancre
16	125	2mm	3240L-3	Anker	Anchor	Anker	Ancre
8	126	2mm	3240L-2	Anker	Anchor	Anker	Ancre
8	127	2mm	3240L-2	Anker	Anchor	Anker	Ancre
1	128	2mm	3240L-2	Dæk	Deck	Deck	Pont
2	129	2mm	3240L-2	Ræling	Rail	Reling	Gouvernail
1	130	2mm	3240L-3	Kofilnaglebænk	Belaying pin bench	Belegnägelbank	Ratelier de cordage

2	131	2mm	3240L-3	Liste	Strip	Leiste	Baguette
2	132	2mm	3240L-1	Ræling	Rail	Reling	Gouvernail
1	133	2mm	3240L-1	Ræling	Rail	Reling	Gouvernail
1	134	2mm	3240L-3	Ræling	Rail	Reling	Gouvernail
1	135	2mm	3240L-2	Mastfod	Maststep	Mastfuss	Pommes de mat
1	136	2mm	3240L-2	Mastfod	Maststep	Mastfuss	Pommes de mat
1	137	2mm	3240L-2	Kofilnaglebænk	Belaying pin bench	Belegnägelbank	Ratelier de cordage
2	138	2mm	3240L-1	Kofilnaglebænk	Belaying pin bench	Belegnägelbank	Ratelier de cordage
2	139	2mm	3240L-1	Kofilnaglebænk	Belaying pin bench	Belegnägelbank	Ratelier de cordage
2	140	2mm	3240L-3	Røstbrædt	Chainboard	Rüstbrett	Cadènes de grand mat
2	141	2mm	3240L-2	Røstbrædt	Chainboard	Rüstbrett	Cadènes de grand mat
2	142	2mm	3240L-2	Rælingsstøtter	Rail stanchions	Relingsstützen	Chandeliers
1	143	2mm	3240L-2	Rat	Wheel	Steurrad	Roue
1	144	2mm	3240L-2	Rat	Wheel	Steurrad	Roue
1	145	2mm	3240L-2	Ræling	Rail	Reling	Gouvernail
1	146	2mm	3240L-3	Ræling	Rail	Reling	Gouvernail
1	147	2mm	3240L-2	Dæk	Deck	Deck	Pont
1	148	2mm	3240L-2	Mastfod	Maststep	Mastfuss	Pommes de mat
1	149	2mm	3240L-2	Holder, flagstang	flagpole, bracket	Fahnenmast Halterung	support de mât
1	150	2mm	3240L-2	Kofilnaglebænk	Belaying pin bench	Belegnägelbank	Ratelier de cordage
2	151	2mm	3240L-2	Hjælpestykker	Auxiliary pieces	Hilfsstücke	Pièce annexes
2	152	2mm	3240L-3	Hjælpestykker	Auxiliary pieces	Hilfsstücke	Pièce annexes
2	153	2mm	3240L-3	Hjælpestykker	Auxiliary pieces	Hilfsstücke	Pièce annexes
2	154	2mm	3240L-3	Hjælpestykker	Auxiliary pieces	Hilfsstücke	Pièce annexes
2	155	2mm	3240L-3	Hjælpestykker	Auxiliary pieces	Hilfsstücke	Pièce annexes
2	156	2mm	3240L-3	Hjælpestykker	Auxiliary pieces	Hilfsstücke	Pièce annexes
2	157	2mm	3240L-3	Hjælpestykker	Auxiliary pieces	Hilfsstücke	Pièce annexes
2	158	2mm	3240L-3	Hjælpestykker	Auxiliary pieces	Hilfsstücke	Pièce annexes
2	159	2mm	3240L-3	Hjælpestykker	Auxiliary pieces	Hilfsstücke	Pièce annexes
2	160	2mm	3240L-1	Røstbrædt	Chainboard	Rüstbrett	Cadènes de grand mat
2	161	2mm	3240L-3	Røstbrædt	Chainboard	Rüstbrett	Cadènes de grand mat
8	162	2mm	3240L-2	Hængsel	Hinge	Scharnier	Charnière
2	163	2mm	3240L-3	Skot, Halvdæk	Bulkhead, Quarterdeck	Schott, Quarterdeck	Cloison, Avant pont
2	164	2mm	3240L-3	Skot, Halvdæk	Bulkhead, Quarterdeck	Schott, Quarterdeck	Cloison, Avant pont

1	165	2mm	3240L-3	Skot, Halvdæk	Bulkhead, Quarterdeck	Schott, Quarterdeck	Cloison, Avant pont
2	166	2mm	3240L-3	Mærs	Top	Mars	Hune
4	167	2mm	3240L-2	Mærs	Top	Mars	Hune
2	168	2mm	3240L-1	Mastbeslag	Mast fittings	Mastbeschlag	Garniture de mât
2	169	2mm	3240L-2	Mastbeslag	Mast fittings	Mastbeschlag	Garniture de mât
1	170	2mm	3240L-2	Mastbeslag	Mast fittings	Mastbeschlag	Garniture de mât
4	171	2mm	3240L-1	Mærs	Top	Mars	Hune
9	172	2mm	3240L-1	Mærs	Top	Mars	Hune
2	173	2mm	3240L-1	Mærs	Top	Mars	Hune
2	174	1mm	3239L-4	Beklædning	Plankingstrips	Beplankung	Baguettes de bordé
4	175	3mm	3241L	Konsol	Bracket	Halter	Console
2	176	5mm	3238L-3	Ornament	Ornament	Ornamente	Ornament
2	177	1mm	3239L-4	Beklædning	Plankingstrips	Beplankung	Baguettes de bordé
2	178	1mm	3239L-4	Beklædning	Plankingstrips	Beplankung	Baguettes de bordé
2	179	1mm	3239L-3	Beklædning	Plankingstrips	Beplankung	Baguettes de bordé
2	180	1mm	3239L-2	Køl	Keel	Kiel	Quille
2	181	1mm	3239L-4	Køl	Keel	Kiel	Quille
2	182	1mm	3239L-2	Køl	Keel	Kiel	Quille
2	183	1mm	3239L-2	Ror	Rudder	Ruder	Gouvernail
1	183A	5mm	3238L-3	Ror	Rudder	Ruder	Gouvernail
2	184	1mm	3239L-2	Ornament	Ornament	Ornamente	Ornament
2	185	1mm	3239L-2	Ornament	Ornament	Ornamente	Ornament
2	186	1mm	3239L-2	Ornament	Ornament	Ornamente	Ornament
2	187	1mm	3239L-2	Liste	Strip	Leisten	Baguette
2	188	1mm	3239L-2	Liste	Strip	Leisten	Baguette
2	189	1mm	3239L-2	Liste	Strip	Leisten	Baguette
1	190	1mm	3239L-2	Ristværk	Grating	Grätting	Grillage
1	191	1mm	3239L-2	Skot	Bulkhead	Schott	Cloison
1	192	1mm	3239L-1	Ornament	Ornament	Ornamente	Ornament
2	193	1mm	3239L-1	Faconstykke	Formed piece	Faconbeplankung	Pièce formée
2	194	1mm	3239L-1	Ornament	Ornament	Ornamente	Ornament
2	195	1mm	3239L-1	Toilet	Toilet	Toilette	Toilette
2	196	1mm	3239L-1	Ristværk	Grating	Grätting	Grillage
1	197	1mm	3239L-1	Ristværk	Grating	Grätting	Grillage

1	198	1mm	3239L-1	Mærs	Top	Mars	Hune
1	199	1mm	3239L-1	Mærs	Top	Mars	Hune
1	200	1mm	3239L-2	Mærs	Top	Mars	Hune
1	201	1mm	3239L-2	Mærs	Top	Mars	Hune
1	202	1mm	3239L-2	Mærs	Top	Mars	Hune
1	203	1mm	3239L-2	Mærs	Top	Mars	Hune
2	204	1mm	3239L-2	Beklædning	Plankingstrips	Beplankung	Baguettes de bordé
2	205	1mm	3239L-2	Beklædning	Plankingstrips	Beplankung	Baguettes de bordé
2	206	1mm	3239L-2	Ristværk	Grating	Grätting	Grillage
1	207	1mm	3239L-1	Ristværk	Grating	Grätting	Grillage
10	208	1mm	3239L-1	Lejder	Ladder	Leiter	Echelle
52	209	1mm	3239L-2	Lejder	Ladder	Leiter	Echelle
1	210	1mm	3239L-2	Bjælkebugt	Former	Balkbögen	Traverses
2	211	3mm	3241L	Hjælpestykker	Auxiliary pieces	Hilfsstücke	Pièce annexes
2	212	1mm	3239L-1	Kantliste	Rubbing strake	Sülleiste	Cimaise de rebord
1	213	1mm	3239L-1	Kantliste	Rubbing strake	Sülleiste	Cimaise de rebord
9	214	1mm	3239L-2	Lejder	Ladder	Leiter	Echelle
2	215	1mm	3239L-1	Lejder	Ladder	Leiter	Echelle
2	216	1mm	3239L-1	Lejder	Ladder	Leiter	Echelle
2	217	1mm	3239L-5	Lejder	Ladder	Leiter	Echelle
2	218	1mm	3239L-2	Lejder	Ladder	Leiter	Echelle
2	219	1mm	3239L-2	Lejder	Ladder	Leiter	Echelle
2	220	1mm	3239L-2	Lejder	Ladder	Leiter	Echelle
2	221	1mm	3239L-1	Skot, Halvdæk	Bulkhead, Quarterdeck	Schott, Quarterdeck	Cloison, Avant pont
2	222	1mm	3239L-1	Skot, Halvdæk	Bulkhead, Quarterdeck	Schott, Quarterdeck	Cloison, Avant pont
1	223	1mm	3239L-1	Skot, Halvdæk	Bulkhead, Quarterdeck	Schott, Quarterdeck	Cloison, Avant pont
1	224	2mm	3240L-2	Bjælkebugt	Former	Balkbögen	Traverses
2	225	1mm	3239L-1	Skylight	Skylight	Oberlicht	Claire voie
2	226	1mm	3239L-1	Skylight	Skylight	Oberlicht	Claire voie
1	227	1mm	3239L-1	Skylight	Skylight	Oberlicht	Claire voie
2	228	1mm	3239L-1	Signal-flagreol	Signal flag storage	Signal Flagge Lagerung	stockage drapeau de signalisation
2	229A	1mm	3239L-1	Signal-flagreol	Signal flag storage	Signal Flagge Lagerung	stockage drapeau de signalisation
2	229B	1mm	3239L-1	Signal-flagreol	Signal flag storage	Signal Flagge Lagerung	stockage drapeau de signalisation
2	230	1mm	3239L-1	Signal-flagreol	Signal flag storage	Signal Flagge Lagerung	stockage drapeau de signalisation

2	231	1mm	3239L-1	Signal-flagreol	Signal flag storage	Signal Flagge Lagerung	stockage drapeau de signalisation
1	232	1mm	3239L-1	Galleri	Gallery	Galerie	Galerie
1	233	1mm	3239L-1	Galleri	Gallery	Galerie	Galerie
1	234	1mm	3239L-1	Galleri	Gallery	Galerie	Galerie
1	235	1mm	3239L-1	Galleri	Gallery	Galerie	Galerie
4	235A	1mm	3239L-1	Galleri	Gallery	Galerie	Galerie
8	236	1mm	3239L-1	Røstjern	Chainplate	Rüsteisen	Cadénes
2	237	1mm	3239L-1	Vinduer, Galleri	Windows, Gallery	Fenster Galerie	Fenêtres galerie
2	238	1mm	3239L-1	Vinduer, Galleri	Windows, Gallery	Fenster Galerie	Fenêtres galerie
2	239	1mm	3239L-1	Galleri, Side	Gallery, Side	Gallerie, Seiten	Galerie, Côte
2	240	1mm	3239L-1	Galleri, Side	Gallery, Side	Gallerie, Seiten	Galerie, Côte
2	241	1mm	3239L-1	Vinduer, Galleri	Windows, Gallery	Fenster Galerie	Fenêtres galerie
2	242	1mm	3239L-1	Vinduer, Galleri	Windows, Gallery	Fenster Galerie	Fenêtres galerie
2	243	1mm	3239L-1	Galleri, Side	Gallery, Side	Gallerie, Seiten	Galerie, Côte
2	244	1mm	3239L-1	Galleri, Side	Gallery, Side	Gallerie, Seiten	Galerie, Côte
2	245	1mm	3239L-1	Vinduer, Galleri	Windows, Gallery	Fenster Galerie	Fenêtres galerie
2	246	1mm	3239L-1	Vinduer, Galleri	Windows, Gallery	Fenster Galerie	Fenêtres galerie
2	247	1mm	3239L-1	Galleri, Side	Gallery, Side	Gallerie, Seiten	Galerie, Côte
2	248	1mm	3239L-5	Ornament	Ornament	Ornements	Ornament
2	249	1mm	3239L-1	Galleri, Side	Gallery, Side	Gallerie, Seiten	Galerie, Côte
2	250	1mm	3239L-1	Galleri, Side	Gallery, Side	Gallerie, Seiten	Galerie, Côte
2	251	1mm	3239L-1	Liste	Strip	Leisten	Baguette
1	252	1mm	3239L-1	Liste	Strip	Leisten	Baguette
2	253	1mm	3239L-1	Liste	Strip	Leisten	Baguette
2	254	1mm	3239L-1	Liste	Strip	Leisten	Baguette
11	255	1mm	3239L-1	Lejder	Ladder	Leiter	Echelle
11	255	1mm	3239L-2	Lejder	Ladder	Leiter	Echelle
8	256	1mm	3239L-1	Lejder	Ladder	Leiter	Echelle
8	256	1mm	3239L-2	Lejder	Ladder	Leiter	Echelle
1	257	1mm	3239L-1	Lejder	Ladder	Leiter	Echelle
1	257	1mm	3239L-2	Lejder	Ladder	Leiter	Echelle
5	258	1mm	3239L-1	Lejder	Ladder	Leiter	Echelle
5	258	1mm	3239L-2	Lejder	Ladder	Leiter	Echelle
2	259	1mm	3239L-2	Liste	Strip	Leisten	Baguette

2	260	1mm	3239L-2	Ornament	Ornament	Ornamente	Ornament
2	261	1mm	3239L-2	Ornament	Ornament	Ornamente	Ornament
4	262	1mm	3239L-1	Ornament	Ornament	Ornamente	Ornament
28	263	1mm	3239L-1	Kanonport	Gunports	Stückerpforte	Sabord
18	264	1mm	3239L-2	Kanonport	Gunports	Stückerpforte	Sabord
28	265	1mm	3239L-1	Kanonport	Gunports	Stückerpforte	Sabord
4	266	1mm	3239L-2	Kanonport	Gunports	Stückerpforte	Sabord
4	267	1mm	3239L-2	Kanonport	Gunports	Stückerpforte	Sabord
4	268	1mm	3239L-2	Kanonport	Gunports	Stückerpforte	Sabord
156	269	1mm	3239L-2	Røstjern	Chainplate	Rüsteisen	Cadénes
32	270	1mm	3239L-2	Ornament	Ornament	Ornamente	Ornament
4	271	1mm	3239L-1	Ornament	Ornament	Ornamente	Ornament
24	272	1mm	3239L-1	Ornament	Ornament	Ornamente	Ornament
2	273	1mm	3239L-2	Ornament	Ornament	Ornamente	Ornament
1	274	2mm	3240L-2	Dæk	Deck	Deck	Pont
4	275	3mm	3241L	Hjælpestykker	Auxiliary pieces	Hilfsstücke	Pièce annexes
4	276	1mm	3239L-2	Kanon	Canon	Geschütze	Canon
2	277	2mm	3240L-1	Kanon	Canon	Geschütze	Canon
2	278	2mm	3240L-1	Kanon	Canon	Geschütze	Canon
2	279	2mm	3240L-1	Kanon	Canon	Geschütze	Canon
2	280	1mm	3239L-5	Kanon	Canon	Geschütze	Canon
1	281	3mm	3241L	Nathus	Binnacle	Kompasshaus	Habitacle
3	282	1mm	3239L-5	Del til bovspryd	Bowsprit,part	Teil für Bugspriet	partie de Beaupré
18	283	1mm	3239L-5	Mastbeslag	Mast fittings	Mastbeschlag	Garniture de mât
1	284	1mm	3239L-5	Ornament	Ornament	Ornamente	Ornament
1	285	1mm	3239L-5	Ornament	Ornament	Ornamente	Ornament
1	286	1mm	3239L-5	Navneskilt	Nameplate	Namensschild	Plaque
1	287	1mm	3239L-5	Ornament	Ornament	Ornamente	Ornament
1	288	1mm	3239L-5	Ornament	Ornament	Ornamente	Ornament
1	289	1mm	3239L-5	Ornament	Ornament	Ornamente	Ornament
2	325	1mm	3239L-5	Nathus	Binnacle	Kompass	Habitacle
2	326	1mm	3239L-5	Nathus	Binnacle	Kompass	Habitacle
1	327	1mm	3239L-5	Nathus	Binnacle	Kompass	Habitacle
4	328	1mm	3239L-5	Konsol	Bracket	Halter	Console

	290-324			Master, Ræer	Masts, Yards	Masten, Råhen	Mats, Vergues
	329-332			Master, Ræer	Masts, Yards	Masten, Råhen	Mats, Vergues
	3	Ø3x300MM		Rundstok	Round stick	Rundstab	Baguette ronde
	2	Ø3x200MM		Rundstok	Round stick	Rundstab	Baguette ronde
	1	Ø4x160MM		Rundstok	Round stick	Rundstab	Baguette ronde
	1	Ø4x190MM		Rundstok	Round stick	Rundstab	Baguette ronde
	2	Ø4x200MM		Rundstok	Round stick	Rundstab	Baguette ronde
	2	Ø4x210MM		Rundstok	Round stick	Rundstab	Baguette ronde
	1	Ø4x240MM		Rundstok	Round stick	Rundstab	Baguette ronde
	1	Ø4x250MM		Rundstok	Round stick	Rundstab	Baguette ronde
	1	Ø4x260MM		Rundstok	Round stick	Rundstab	Baguette ronde
	1	Ø4x300MM		Rundstok	Round stick	Rundstab	Baguette ronde
	2	Ø4x400MM		Rundstok	Round stick	Rundstab	Baguette ronde
	6	Ø6x300MM		Rundstok	Round stick	Rundstab	Baguette ronde
	3	Ø6x250MM		Rundstok	Round stick	Rundstab	Baguette ronde
	2	Ø8x400MM		Rundstok	Round stick	Rundstab	Baguette ronde
	1	Ø8x260MM		Rundstok	Round stick	Rundstab	Baguette ronde
	3	Ø12x350MM		Rundstok	Round stick	Rundstab	Baguette ronde
2		1,8x2x650	Obechi	Liste	Strip	Leiste	Baguette
2		1,8x4x650	Obechi	Liste	Strip	Leiste	Baguette
10		1,5x3x500	Pine	Liste	Strip	Leiste	Baguette
1		1,8x2x550	Pine	Liste	Strip	Leiste	Baguette
72		0,7x4x550	Annegre	Liste	Strip	Leiste	Baguette
1		3x3x500	Basswood	Liste	Strip	Leiste	Baguette
80		1,8x7x820	Obechi	Liste	Strip	Leiste	Baguette
28	F10	40mm	Brass	Røstjern	Chainplate	Rüsteisen	Cadènes
18	F39	25cm	Brass	Messingtråd	Brasswire	Messingdraht	Fil de laiton
1	F70	100m		Rigningstråd	Rigging thread	Takelgarn	Fil de gréement
1	F71	100m		Rigningstråd	Rigging thread	Takelgarn	Fil de gréement
3	F72	30m		Rigningstråd	Rigging thread	Takelgarn	Fil de gréement
1	F73	6m		Rigningstråd	Rigging thread	Takelgarn	Fil de gréement
1	F74	0,7m		Rigningstråd	Rigging thread	Takelgarn	Fil de gréement
60	F54	8mm	Brass	Kofilnagle	Belaying pin	Belegnägel	Cabillots

1	F56	ø5x5,5mm	Brass	Klokke	Bell	Glocken	Cloche
88	F81	18mm	Brass	Kanon	Canon	Kanon	Canon
4	F120	ø16mm	Brass/plastic	Lanterner	Lights	Lanternen	Feux de navigation
18	F163	40mm	Brass	Kanon	Canon	Kanon	Canon
5	F164		Plastic	Lavet	Carriage	Lafette	Affut de canon
4	F224	12mm	Brass	Gelænderstøtte	Rail-stanchion	Relingstützen	Chandeliers
12	F285	5,5mm	Brass	Øjebolt	Eye bolt	Augenbolzen	Pitons
0,2	F327	2x1,5mm	Brass	Kæde	Chain	Kette	Chaîne
1	F409	ø1,5x250mm	Brass	Messingtråd	Brasswire	Messingdraht	Fil de laiton
26	F488	ø3mm		Perle	Pearl	Perlen	Perle
2	F490-1		Brass	Kanon	Canon	Kanon	Canon
20	F493	15mm	Brass	Gelænderstøtte	Rail-stanchion	Relingstützen	Chandeliers
3	F502		Brass	Ring	Ring	Ring	Bague
34	F537	25mm	Brass	Røstjern	Chainplate	Rüsteisen	Cadènes
42	F539	40mm	Brass	Røstjern	Chainplate	Rüsteisen	Cadènes
80	F664	11mm	Brass	Øjebolt	Eye bolt	Augenbolzen	Pitons
112	F080	Ø5mm	Wood	Jomfru	Dead eye	Jungfern	Cap de mouton
112	F219	Ø7mm	Wood	Jomfru	Dead eye	Jungfern	Cap de mouton
84	F064-1	5mm	Wood	Enkelt blok	Single blocks	Einzel, block	Poulies simple
8	F681	5x5x7,5mm	Wood	Trippel blok	Triple block	Triple-Block	Triple bloc
18	F223	7mm	Wood	Dobbelt blok	Double blocks	Doppel, block	Poulies doubles
23	F767	4x2x2,5mm	Wood	Enkelt blok	Single blocks	Einzel, block	Poulies simple
2	F920	21mm	Brass	Rat	Wheel	Steerrad	Roue
4	F921	Ø2x8mm	Brass	Rør	Tube	Rohre	tube
8	F922	Ø3x2mm	Brass	Ring	Ring	Ring	Bague
8	F923	Ø4x2mm	Brass	Ring	Ring	Ring	Bague
8	F924	Ø5x2mm	Brass	Ring	Ring	Ring	Bague
4	F925	Ø6x2mm	Brass	Ring	Ring	Ring	Bague
4	F926	Ø7x2mm	Brass	Ring	Ring	Ring	Bague
8	F927	Ø9x2mm	Brass	Ring	Ring	Ring	Bague
30	F928	Ø13x2mm	Brass	Ring	Ring	Ring	Bague
1	F929	Ø4x4mm	Brass	Rør	Tube	Rohre	tube
1	F930	Ø6x35mm	Brass	Rør	Tube	Rohre	tube

2	F773	0,4x2,5x250mm	Brass	Bånd	Tape	Band	Bande
1	F932		Brass	Galionsfigur	Figurehead	Gallionsfigur	Figure de proue
1				Byggevejledning	Building instruction	Bauanleitung	Instruction de montage
1				Hovedtegning Plan 1+4	Maindrawing 1+4	Zeichnung 1+4	Plan 1+4
1				Hovedtegning Plan 2+3	Maindrawing 2+3	Zeichnung 2+3	Plan 2+3
1		Flag150		Flag	Flag	Flagge	Drapeau
1			Acrylic	Vinduer	Windows	Fenster	Fenêtres
1		300x600mm		Net/Gelænder	Net/railing	Netz/reling	Filet/courante

Table contents for "HMS Victory" Art. No. 498

Pcs.	No.	Dimension	Material	NL	E	I	P
1	1	5mm	3238L - 3	Kiel	Quilla	Chiglia	Quilha
1	2	5mm	3238L - 4	Kiel	Quilla	Chiglia	Quilha
1	3	5mm	3238L - 3	Kiel	Quilla	Chiglia	Quilha
1	4	5mm	3238L - 3	Spant	Cuaderna	Ordinata	Armacao
1	5	5mm	3238L - 2	Spant	Cuaderna	Ordinata	Armacao
1	6	5mm	3238L - 3	Spant	Cuaderna	Ordinata	Armacao
1	7	5mm	3238L - 2	Spant	Cuaderna	Ordinata	Armacao
1	8	5mm	3238L - 3	Hulpspanten	Cuaderna de apoyo	Ordinata di supporto	Arracáo de apoio
1	9	5mm	3238L - 1	Spant	Cuaderna	Ordinata	Armacao
1	10	5mm	3238L - 1	Spant	Cuaderna	Ordinata	Armacao
1	11	5mm	3238L - 1	Spant	Cuaderna	Ordinata	Armacao
1	12	5mm	3238L - 1	Spant	Cuaderna	Ordinata	Armacao
1	13	5mm	3238L - 1	Spant	Cuaderna	Ordinata	Armacao
1	14	5mm	3238L - 3	Hulpspanten	Cuaderna de apoyo	Ordinata di supporto	Arracáo de apoio
2	15	5mm	3238L - 2	Hulpspanten	Cuaderna de apoyo	Ordinata di supporto	Arracáo de apoio
1	16	5mm	3238L - 3	Spant	Cuaderna	Ordinata	Armacao
1	17	5mm	3238L - 2	Spant	Cuaderna	Ordinata	Armacao
1	18	5mm	3238L - 2	Hulpspanten	Cuaderna de apoyo	Ordinata di supporto	Arracáo de apoio
1	19	5mm	3238L - 2	Hulpspanten	Cuaderna de apoyo	Ordinata di supporto	Arracáo de apoio
1	20	5mm	3238L - 3	Hulpspanten	Cuaderna de apoyo	Ordinata di supporto	Arracáo de apoio
1	21	5mm	3238L - 2	Spant	Cuaderna	Ordinata	Armacao
1	22	5mm	3238L - 2	Spant	Cuaderna	Ordinata	Armacao
1	23	5mm	3238L - 2	Hulpspanten	Cuaderna de apoyo	Ordinata di supporto	Arracáo de apoio

2	24	5mm	3238L - 2	Hulpspanten	Cuaderna de apoyo	Ordinata di suporto	Arracáo de apoio
2	25	5mm	3238L - 2	Paal	Poste	Supporto	Poste
2	26	5mm	3238L - 3	Kraan Spantdelen	Tablón de grúa	Trave della gru	Guindaste
2	27	5mm	3238L - 1	Boeg hout	Botalon de madera	Bom legname	madeira Bujarrona
2	28	5mm	3238L - 1	Halter	Consola	Consolle	Suporte
2	29	5mm	3238L - 3	Broekstuk galjoen	Borda	Parapetto	Amurada
4	30	5mm	3238L - 1	Paal	Poste	Supporto	Poste
2	31	5mm	3238L - 3	Broekstuk galjoen	Borda	Parapetto	Amurada
2	32	5mm	3238L - 3	Mastbeslag	Herrajes de palo	Accessori albero	Braçadeira do mastro
1	33	5mm	3238L - 3	Mastbeslag	Herrajes de palo	Accessori albero	Braçadeira do mastro
6	34	5mm	3238L - 3	Steunen spantdelen	Viga de soporte	Travi di sostegno	Poste de apoio
1	35	5mm	3238L - 2	(Verwijdering deel)	(Eliminación de parte)	(Smaltimento parte)	(Eliminação parcial)
4	36	5mm	3238L - 3	Ingang	Entrada	Ingresso	Entrada
2	37	5mm	3238L - 3	Broekstuk galjoen	Borda	Parapetto	Amurada
1	38	5mm	3238L - 3	Standaard	Grada	Supporto	Pé do Suporte de Casco
1	39A	5mm	3238L - 2	Standaard	Grada	Supporto	Pé do Suporte de Casco
1	39B	5mm	3238L - 2	Standaard	Grada	Supporto	Pé do Suporte de Casco
1	40	5mm	3238L - 3	Standaard	Grada	Supporto	Pé do Suporte de Casco
1	41	5mm	3238L - 3	Spantdelen	Traversas	Trave superiore	Viga superior
2	42	5mm	3238L - 3	Deel gemak (WC)	Lavabo	Gabinetto	Toalete
8	42A	5mm	3238L - 3	Halter	Consola	Consolle	Suporte
2	42B	5mm	3238L - 3	Halter	Consola	Consolle	Suporte
2	43	3mm	3241L	Gevormd deel	Plantilla	Pezzo prefabbricato	Amurada de popa
2	44	3mm	3241L	Paal	Poste	Supporto	Poste
1	45	3mm	3241L	Knie op boegspriet	Para bauprés	Per bompresso	Para o Gurupés
1	46	3mm	3241L	Knie op boegspriet	Para bauprés	Per bompresso	Para o Gurupés
1	47	3mm	3241L	Schot	Manpara	Paratia	Paredes divisórias
2	48	3mm	3241L	Verhaalklamp	Bocina	Rinforzo	Tube do escovém
2	49	3mm	3241L	kanonskogel, opslagruimte	bala de cañón, almacenamiento	Palla di cannone, immagazzinamento	bola de canhão, armazenamento
2	50	3mm	3241L	Knie galjoen	Rodilla	Ginocchio	Cotovelo
2	51	3mm	3241L	Knie galjoen	Rodilla	Ginocchio	Cotovelo
2	52	3mm	3241L	Kanon	Cañón	Cannone	Canhão
2	53	3mm	3241L	Kanon	Cañón	Cannone	Canhão

2	54	3mm	3241L	Kanon	Cañón	Cannone	Canhão
1	55	Ø3x15mm	Wood	Paal	Poste	Supporto	Poste
2	56	3mm	3241L	Paal	Poste	Supporto	Poste
4	57	3mm	3241L	Broekstuk galjoen	Borda	Parapetto	Amurada
2	58	3mm	3241L	Klokkentoren	Campanario	Campanile	Campanário
2	59	3mm	3241L	Klokkentoren	Campanario	Campanile	Campanário
2	60	3mm	3241L	Klokkentoren	Campanario	Campanile	Campanário
1	61	3mm	3241L	Spantdelen	Curvatón	Trave superiore	Fôrma
2	62	3mm	3241L	Steunen spantdelen	Viga de soporte	Travi di sostegno	Poste de apoio
1	63	3mm	3241L	Spantdelen	Curvatón	Trave superiore	Fôrma
20	64	3mm	3241L	Paal	Poste	Supporto	Poste
2	65	3mm	3241L	Broekstuk galjoen	Borda	Parapetto	Amurada
2	66	3mm	3241L	Paal	Poste	Supporto	Poste
4	67	3mm	3241L	Ingang	Entrada	Ingresso	Entrada
2	68	3mm	3241L	Halter	Consola	Consolle	Suporte
2	69	3mm	3241L	Halter	Consola	Consolle	Suporte
2	70	3mm	3241L	Broekstuk galjoen	Borda	Parapetto	Amurada
1	71	3mm	3241L	Dekdoorvoer mast	Base del palo	Piede d'albero	Degrau do mastro
2	72	3mm	3241L	Paal	Poste	Supporto	Poste
1	73	3mm	3241L	Boom zadel	Boom silla	Boom sella	sela Boom
4	74	3mm	3241L	Boom vork	Boom tenedor	Boom forchetta	Garfo Boom
2	75	3mm	3241L	Voor reddingboei	Bote salvavida	Per scialuppa	Assento
2	76	3mm	3241L	Voor reddingboei	Bote salvavida	Per scialuppa	Assento
2	77	3mm	3241L	Verhaalklamp	Bocina	Rinforzo	Tube do escovém
2	78	3mm	3241L	Signaal vlag opslag	Señal de almacenamiento de abanderamiento	Segnale bandiera di stoc-caggio	Sinal de armazenamento bandeira
2	79	3mm	3241L	Spantdelen	Curvatón	Trave superiore	Fôrma
2	80	3mm	3241L	Spantdelen	Curvatón	Trave superiore	Fôrma
2	81	3mm	3241L	Vulstukken	Trozo de ayuda	Pezzo ausiliario	Peças auxiliares
1	82	3mm	3241L	Vulstukken	Trozo de ayuda	Pezzo ausiliario	Peças auxiliares
1	83	3mm	3241L	Vulstukken	Trozo de ayuda	Pezzo ausiliario	Peças auxiliares
1	84	3mm	3241L	Vulstukken	Trozo de ayuda	Pezzo ausiliario	Peças auxiliares
2	85	3mm	3241L	Wangen	Verga	Coffa	Topo
2	86	2mm	3241L	Strip	Listón	Listello	Tira

2	87	3mm	3241L	Wangen	Verga	Coffa	Topo
2	88	3mm	3241L	Wangen	Verga	Coffa	Topo
2	89	3mm	3241L	Wangen	Verga	Coffa	Topo
2	90	3mm	3241L	Wangen	Verga	Coffa	Topo
2	91	3mm	3241L	Wangen	Verga	Coffa	Topo
1	92	3mm	3241L	Wangen	Verga	Coffa	Topo
1	93	3mm	3241L	Wangen	Verga	Coffa	Topo
1	94	3mm	3241L	Wangen	Verga	Coffa	Topo
2	95	3mm	3241L	Vulstukken	Trozo de ayuda	Pezzo ausiliario	Peças auxiliares
1	96	2mm	3240L-2	Knie op boegspriet	Para bauprés	Per bompresso	Para o Gurupés
2	97	2mm	3240L-3	Knie op boegspriet	Para bauprés	Per bompresso	Para o Gurupés
2	98	2mm	3240L-1	Vulstukken	Trozo de ayuda	Pezzo ausiliario	Peças auxiliares
2	99	2mm	3240L-2	Verhaalklambret	Escobén	Listelli passacavi	Tampo do escovém
1	100	3mm	3241L	Spant	Cuaderna	Ordinata	Armacao
1	101	3mm	3241L	Spant	Cuaderna	Ordinata	Armacao
1	102	3mm	3241L	Spant	Cuaderna	Ordinata	Armacao
1	103	3mm	3241L	Spant	Cuaderna	Ordinata	Armacao
1	104	2mm	3240L-2	Spant	Cuaderna	Ordinata	Armacao
1	105	2mm	3240L-2	Gangboord	Pasarela	Passerella	Ponte de passagem
2	106	2mm	3240L-3	Boeg hout	Botalon de madera	Bom legname	madeira Bujarrona
2	107	2mm	3240L-2	Sieraad	Adorno	Decorazioni	Adorno
6	108	2mm	3240L-3	Vulstukken	Trozo de ayuda	Pezzo ausiliario	Peças auxiliares
1	109	2mm	3240L-3	Broekstuk galjoen	Borda	Parapetto	Amurada
1	110	2mm	3240L-3	Broekstuk galjoen	Borda	Parapetto	Amurada
2	111	2mm	3240L-3	Broekstuk galjoen	Borda	Parapetto	Amurada
1	112	2mm	3240L-3	Spantdelen	Curvatón	Trave superiore	Fôrma
2	113	2mm	3240L-2	Nagelbank	Caballetes	Cavaletto	Assento de amarração
2	114	2mm	3240L-2	Broekstuk galjoen	Borda	Parapetto	Amurada
2	115	2mm	3240L-2	Broekstuk galjoen	Borda	Parapetto	Amurada
1	116	2mm	3240L-1	Dek	Cubierta	Ponte	Convés
2	117	2mm	3240L-3	Rusten	Cadenote	Asse di catene	Correntes do Mastro Principal
8	118	2mm	3240L-2	Railingspalen	Soporte de pasamanos	Supporti per corrimano	Pontaletes da amurada
1	119	2mm	3240L-3	Strip	Listón	Listello	Tira
2	120	2mm	3240L-2	Broekstuk galjoen	Borda	Parapetto	Amurada

4	121	2mm	3240L-2	Broekstuk galjoen	Borda	Parapetto	Amurada
1	122	2mm	3240L-3	Klokkentoren	Campanario	Campanile	Campanário
1	123	2mm	3240L-3	Klokkentoren	Campanario	Campanile	Campanário
8	124	2mm	3240L-2	Anker	Ancla	Ancora	Âncora
16	125	2mm	3240L-3	Anker	Ancla	Ancora	Âncora
8	126	2mm	3240L-2	Anker	Ancla	Ancora	Âncora
8	127	2mm	3240L-2	Anker	Ancla	Ancora	Âncora
1	128	2mm	3240L-2	Dek	Cubierta	Ponte	Convés
2	129	2mm	3240L-2	Broekstuk galjoen	Borda	Parapetto	Amurada
1	130	2mm	3240L-3	Nagelbank	Caballetes	Cavaletto	Assento de amarração
2	131	2mm	3240L-3	Strip	Listón	Listello	Tira
2	132	2mm	3240L-1	Broekstuk galjoen	Borda	Parapetto	Amurada
1	133	2mm	3240L-1	Broekstuk galjoen	Borda	Parapetto	Amurada
1	134	2mm	3240L-3	Broekstuk galjoen	Borda	Parapetto	Amurada
1	135	2mm	3240L-2	Dekdoorvoer mast	Base del palo	Piede d'albero	Degrau do mastro
1	136	2mm	3240L-2	Dekdoorvoer mast	Base del palo	Piede d'albero	Degrau do mastro
1	137	2mm	3240L-2	Nagelbank	Caballetes	Cavaletto	Assento de amarração
2	138	2mm	3240L-1	Nagelbank	Caballetes	Cavaletto	Assento de amarração
2	139	2mm	3240L-1	Nagelbank	Caballetes	Cavaletto	Assento de amarração
2	140	2mm	3240L-3	Rusten	Cadenote	Asse di catene	Correntes do Mastro Principal
2	141	2mm	3240L-2	Rusten	Cadenote	Asse di catene	Correntes do Mastro Principal
2	142	2mm	3240L-2	Railingspalen	Soporte de pasamanos	Supporti per corrimano	Pontaletes da amurada
1	143	2mm	3240L-2	Stuurwiel	Volante	Ruota del timone	Volante do timão
1	144	2mm	3240L-2	Stuurwiel	Volante	Ruota del timone	Volante do timão
1	145	2mm	3240L-2	Broekstuk galjoen	Borda	Parapetto	Amurada
1	146	2mm	3240L-3	Broekstuk galjoen	Borda	Parapetto	Amurada
1	147	2mm	3240L-2	Dek	Cubierta	Ponte	Convés
1	148	2mm	3240L-2	Dekdoorvoer mast	Base del palo	Piede d'albero	Degrau do mastro
1	149	2mm	3240L-2	vlaggenmast beugel	soporte de asta de la bandera	Staffa, pennone	suporte de mastro
1	150	2mm	3240L-2	Nagelbank	Caballetes	Cavaletto	Assento de amarração
2	151	2mm	3240L-2	Vulstukken	Trozo de ayuda	Pezzo ausiliario	Peças auxiliares
2	152	2mm	3240L-3	Vulstukken	Trozo de ayuda	Pezzo ausiliario	Peças auxiliares
2	153	2mm	3240L-3	Vulstukken	Trozo de ayuda	Pezzo ausiliario	Peças auxiliares
2	154	2mm	3240L-3	Vulstukken	Trozo de ayuda	Pezzo ausiliario	Peças auxiliares

2	155	2mm	3240L-3	Vulstukken	Trozo de ayuda	Pezzo ausiliario	Peças auxiliares
2	156	2mm	3240L-3	Vulstukken	Trozo de ayuda	Pezzo ausiliario	Peças auxiliares
2	157	2mm	3240L-3	Vulstukken	Trozo de ayuda	Pezzo ausiliario	Peças auxiliares
2	158	2mm	3240L-3	Vulstukken	Trozo de ayuda	Pezzo ausiliario	Peças auxiliares
2	159	2mm	3240L-3	Vulstukken	Trozo de ayuda	Pezzo ausiliario	Peças auxiliares
2	160	2mm	3240L-1	Rusten	Cadenote	Asse di catene	Correntes do Mastro Principal
2	161	2mm	3240L-3	Rusten	Cadenote	Asse di catene	Correntes do Mastro Principal
8	162	2mm	3240L-2	Hengsel	Charnela	Cerniera	Dobradiça
2	163	2mm	3240L-3	Schot, Voordek	Mamparo, Tilla	Paratia, Ponte anteriore	Paredes divisórias, Meia-coberta
2	164	2mm	3240L-3	Schot, Voordek	Mamparo, Tilla	Paratia, Ponte anteriore	Paredes divisórias, Meia-coberta
1	165	2mm	3240L-3	Schot, Voordek	Mamparo, Tilla	Paratia, Ponte anteriore	Paredes divisórias, Meia-coberta
2	166	2mm	3240L-3	Wangen	Verga	Coffa	Topo
4	167	2mm	3240L-2	Wangen	Verga	Coffa	Topo
2	168	2mm	3240L-1	Mastbeslag	Herrajes de palo	Accessori albero	Braçadeira do mastro
2	169	2mm	3240L-2	Mastbeslag	Herrajes de palo	Accessori albero	Braçadeira do mastro
1	170	2mm	3240L-2	Mastbeslag	Herrajes de palo	Accessori albero	Braçadeira do mastro
4	171	2mm	3240L-1	Wangen	Verga	Coffa	Topo
9	172	2mm	3240L-1	Wangen	Verga	Coffa	Topo
2	173	2mm	3240L-1	Wangen	Verga	Coffa	Topo
2	174	1mm	3239L-4	Rompbekleding	Listónes de forro	Listelli fasciame	Tiras
4	175	3mm	3241L	Halter	Consola	Consolle	Suporte
2	176	5mm	3238L-3	Sieraad	Adorno	Decorazioni	Adorno
2	177	1mm	3239L-4	Rompbekleding	Listónes de forro	Listelli fasciame	Tiras
2	178	1mm	3239L-4	Rompbekleding	Listónes de forro	Listelli fasciame	Tiras
2	179	1mm	3239L-3	Rompbekleding	Listónes de forro	Listelli fasciame	Tiras
2	180	1mm	3239L-2	Kiel	Quilla	Chiglia	Quilha
2	181	1mm	3239L-4	Kiel	Quilla	Chiglia	Quilha
2	182	1mm	3239L-2	Kiel	Quilla	Chiglia	Quilha
2	183	1mm	3239L-2	Roer	Timón	Timone	Leme
1	183A	5mm	3238L-3	Roer	Timón	Timone	Leme
2	184	1mm	3239L-2	Sieraad	Adorno	Decorazioni	Adorno
2	185	1mm	3239L-2	Sieraad	Adorno	Decorazioni	Adorno
2	186	1mm	3239L-2	Sieraad	Adorno	Decorazioni	Adorno
2	187	1mm	3239L-2	Strip	Listón	Listello	Tira

2	188	1mm	3239L-2	Strip	Listón	Listello	Tira
2	189	1mm	3239L-2	Strip	Listón	Listello	Tira
1	190	1mm	3239L-2	Roosterwerk	Emparillado	Piattaforma di poppa	Grade
1	191	1mm	3239L-2	Schot	Manpara	Paratia	Paredes divisórias
1	192	1mm	3239L-1	Sieraad	Adorno	Decorazioni	Adorno
2	193	1mm	3239L-1	Gevormd deel	Plantilla	Pezzo prefabbricato	Amurada de pôpa
2	194	1mm	3239L-1	Sieraad	Adorno	Decorazioni	Adorno
2	195	1mm	3239L-1	Deel gemak (WC)	Lavabo	Gabinetto	Toalete
2	196	1mm	3239L-1	Roosterwerk	Emparillado	Piattaforma di poppa	Grade
1	197	1mm	3239L-1	Roosterwerk	Emparillado	Piattaforma di poppa	Grade
1	198	1mm	3239L-1	Wangen	Verga	Coffa	Topo
1	199	1mm	3239L-1	Wangen	Verga	Coffa	Topo
1	200	1mm	3239L-2	Wangen	Verga	Coffa	Topo
1	201	1mm	3239L-2	Wangen	Verga	Coffa	Topo
1	202	1mm	3239L-2	Wangen	Verga	Coffa	Topo
1	203	1mm	3239L-2	Wangen	Verga	Coffa	Topo
2	204	1mm	3239L-2	Rompbekleding	Listónes de forro	Listelli fasciame	Tiras
2	205	1mm	3239L-2	Rompbekleding	Listónes de forro	Listelli fasciame	Tiras
2	206	1mm	3239L-2	Roosterwerk	Emparillado	Piattaforma di poppa	Grade
1	207	1mm	3239L-1	Roosterwerk	Emparillado	Piattaforma di poppa	Grade
10	208	1mm	3239L-1	Ladder	Escalera	Scaletta	Escada
52	209	1mm	3239L-2	Ladder	Escalera	Scaletta	Escada
1	210	1mm	3239L-2	Spantdelen	Curvatón	Trave superiore	Fôrma
2	211	3mm	3241L	Vulstukken	Trozo de ayuda	Pezzo ausiliario	Peças auxiliares
2	212	1mm	3239L-1	Schuurlijst	Listón de defensa	Bordatura laterale	lista Edge
1	213	1mm	3239L-1	Schuurlijst	Listón de defensa	Bordatura laterale	lista Edge
9	214	1mm	3239L-2	Ladder	Escalera	Scaletta	Escada
2	215	1mm	3239L-1	Ladder	Escalera	Scaletta	Escada
2	216	1mm	3239L-1	Ladder	Escalera	Scaletta	Escada
2	217	1mm	3239L-5	Ladder	Escalera	Scaletta	Escada
2	218	1mm	3239L-2	Ladder	Escalera	Scaletta	Escada
2	219	1mm	3239L-2	Ladder	Escalera	Scaletta	Escada
2	220	1mm	3239L-2	Ladder	Escalera	Scaletta	Escada
2	221	1mm	3239L-1	Schot, Voordek	Mamparo, Tilla	Paratia, Ponte anteriore	Paredes divisórias, Meia-coberta

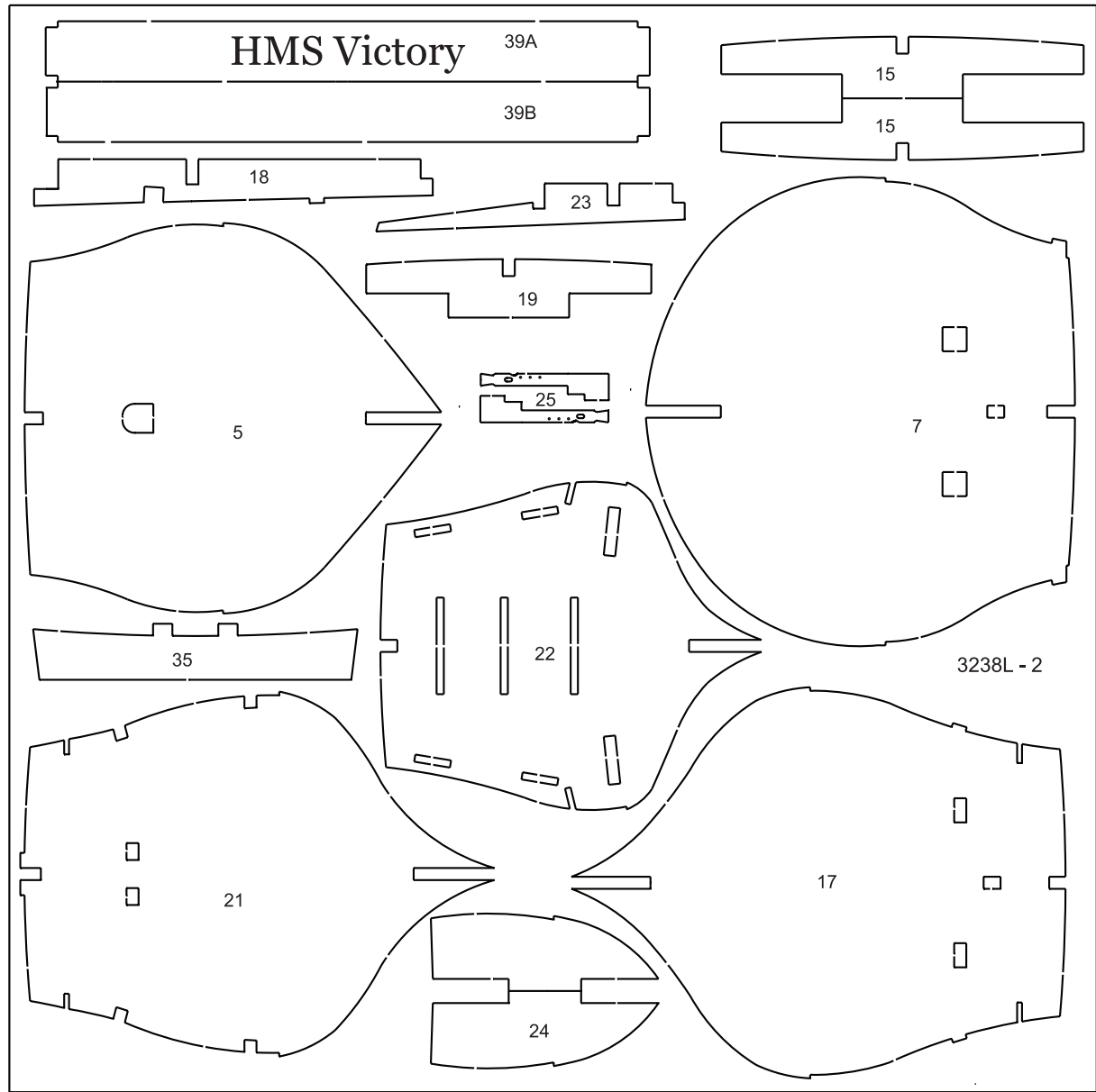
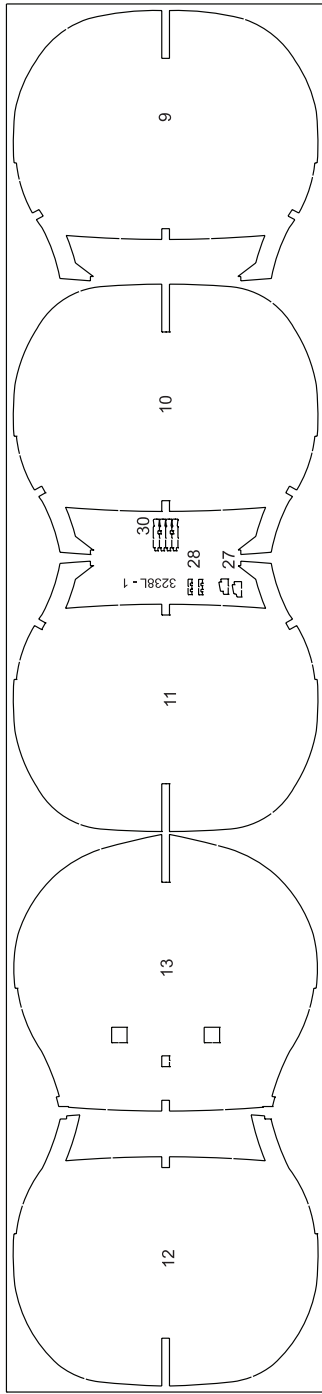
2	222	1mm	3239L-1	Schot, Voordek	Mamparo, Tilla	Paratia, Ponte anteriore	Paredes divisórias, Meia-coberta
1	223	1mm	3239L-1	Schot, Voordek	Mamparo, Tilla	Paratia, Ponte anteriore	Paredes divisórias, Meia-coberta
1	224	2mm	3240L-2	Spantdelen	Curvatón	Trave superiore	Fôrma
2	225	1mm	3239L-1	Bovenlicht	Lumbrera	Osteriggio	Clarabóia
2	226	1mm	3239L-1	Bovenlicht	Lumbrera	Osteriggio	Clarabóia
1	227	1mm	3239L-1	Bovenlicht	Lumbrera	Osteriggio	Clarabóia
2	228	1mm	3239L-1	Signaal vlag opslag	Señal de almacenamiento de abanderamiento	Segnale bandiera di stoc-caggio	Sinal de armazenamento bandeira
2	229A	1mm	3239L-1	Signaal vlag opslag	Señal de almacenamiento de abanderamiento	Segnale bandiera di stoc-caggio	Sinal de armazenamento bandeira
2	229B	1mm	3239L-1	Signaal vlag opslag	Señal de almacenamiento de abanderamiento	Segnale bandiera di stoc-caggio	Sinal de armazenamento bandeira
2	230	1mm	3239L-1	Signaal vlag opslag	Señal de almacenamiento de abanderamiento	Segnale bandiera di stoc-caggio	Sinal de armazenamento bandeira
2	231	1mm	3239L-1	Signaal vlag opslag	Señal de almacenamiento de abanderamiento	Segnale bandiera di stoc-caggio	Sinal de armazenamento bandeira
1	232	1mm	3239L-1	Galerie	Galeria	Galleria	Galeria
1	233	1mm	3239L-1	Galerie	Galeria	Galleria	Galeria
1	234	1mm	3239L-1	Galerie	Galeria	Galleria	Galeria
1	235	1mm	3239L-1	Galerie	Galeria	Galleria	Galeria
4	235A	1mm	3239L-1	Galerie	Galeria	Galleria	Galeria
8	236	1mm	3239L-1	Puttings	Cadenote	Landra	Fixador do ovém
2	237	1mm	3239L-1	Raam galerie	Ventanas, Galería	Finestrini, Galleria	Janelas, Galeria
2	238	1mm	3239L-1	Raam galerie	Ventanas, Galería	Finestrini, Galleria	Janelas, Galeria
2	239	1mm	3239L-1	Galerie, Kant	Galería, Lateral	Galleria, Fiancate	Galeria, Lateral
2	240	1mm	3239L-1	Galerie, Kant	Galería, Lateral	Galleria, Fiancate	Galeria, Lateral
2	241	1mm	3239L-1	Raam galerie	Ventanas, Galería	Finestrini, Galleria	Janelas, Galeria
2	242	1mm	3239L-1	Raam galerie	Ventanas, Galería	Finestrini, Galleria	Janelas, Galeria
2	243	1mm	3239L-1	Galerie, Kant	Galería, Lateral	Galleria, Fiancate	Galeria, Lateral
2	244	1mm	3239L-1	Galerie, Kant	Galería, Lateral	Galleria, Fiancate	Galeria, Lateral
2	245	1mm	3239L-1	Raam galerie	Ventanas, Galería	Finestrini, Galleria	Janelas, Galeria
2	246	1mm	3239L-1	Raam galerie	Ventanas, Galería	Finestrini, Galleria	Janelas, Galeria
2	247	1mm	3239L-1	Galerie, Kant	Galería, Lateral	Galleria, Fiancate	Galeria, Lateral
2	248	1mm	3239L-5	Sieraad	Adorno	Decorazioni	Adorno
2	249	1mm	3239L-1	Galerie, Kant	Galería, Lateral	Galleria, Fiancate	Galeria, Lateral

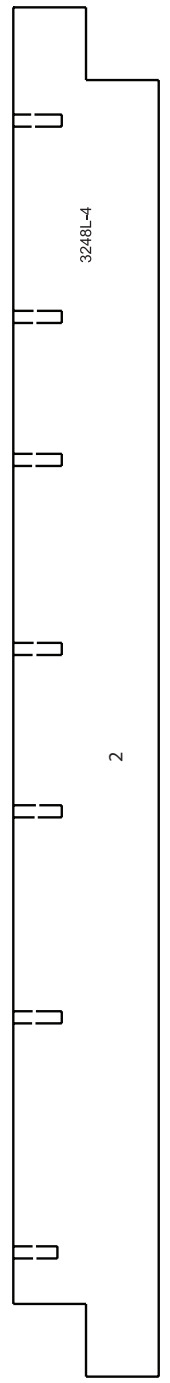
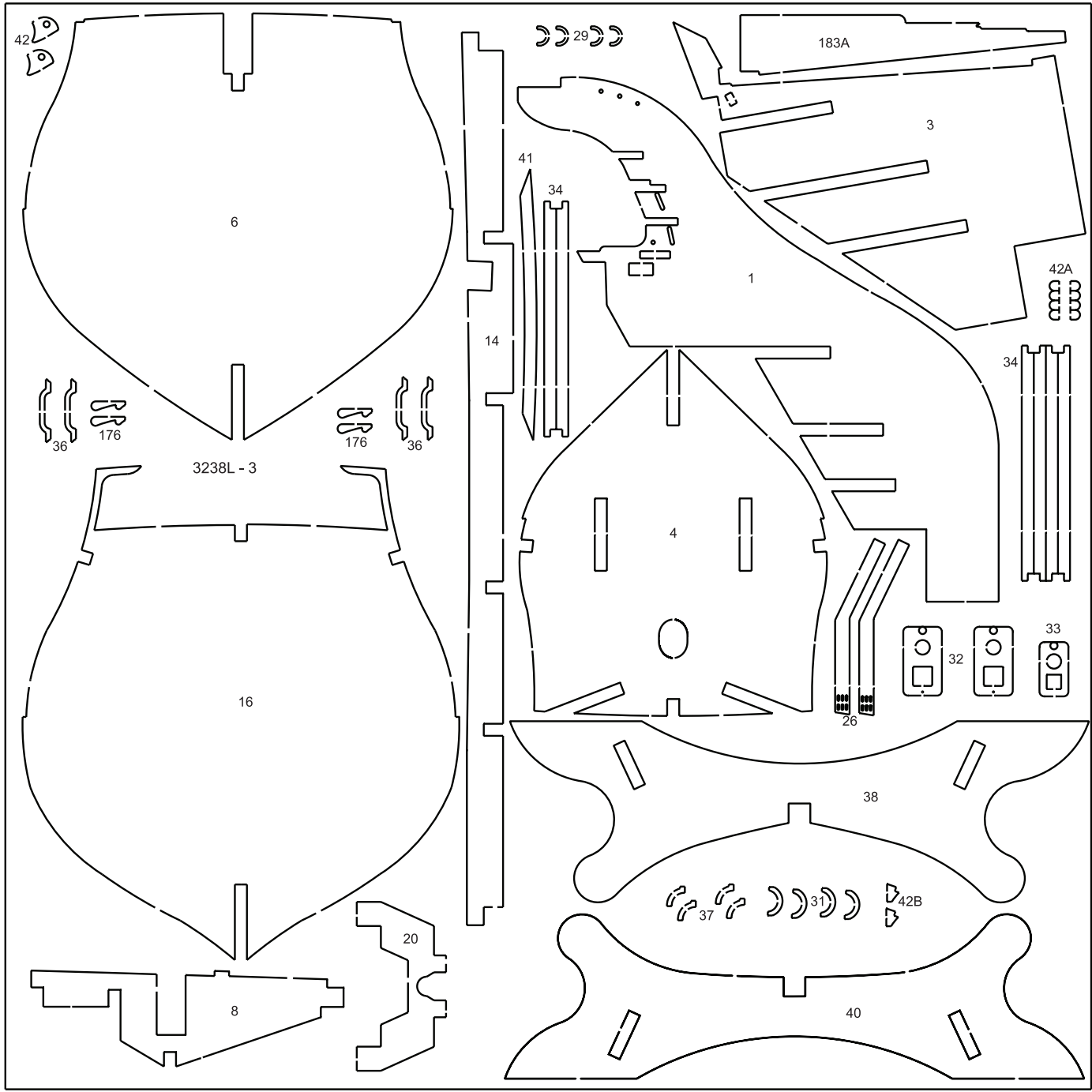
2	250	1mm	3239L-1	Galerie, Kant	Galería, Lateral	Galleria, Fiancate	Galeria, Lateral
2	251	1mm	3239L-1	Strip	Listón	Listello	Tira
1	252	1mm	3239L-1	Strip	Listón	Listello	Tira
2	253	1mm	3239L-1	Strip	Listón	Listello	Tira
2	254	1mm	3239L-1	Strip	Listón	Listello	Tira
11	255	1mm	3239L-1	Ladder	Escalera	Scaletta	Escada
11	255	1mm	3239L-2	Ladder	Escalera	Scaletta	Escada
8	256	1mm	3239L-1	Ladder	Escalera	Scaletta	Escada
8	256	1mm	3239L-2	Ladder	Escalera	Scaletta	Escada
1	257	1mm	3239L-1	Ladder	Escalera	Scaletta	Escada
1	257	1mm	3239L-2	Ladder	Escalera	Scaletta	Escada
5	258	1mm	3239L-1	Ladder	Escalera	Scaletta	Escada
5	258	1mm	3239L-2	Ladder	Escalera	Scaletta	Escada
2	259	1mm	3239L-2	Strip	Listón	Listello	Tira
2	260	1mm	3239L-2	Sieraad	Adorno	Decorazioni	Adorno
2	261	1mm	3239L-2	Sieraad	Adorno	Decorazioni	Adorno
4	262	1mm	3239L-1	Sieraad	Adorno	Decorazioni	Adorno
28	263	1mm	3239L-1	Geschutspoorten	Puertecilla de cañón	Portello di murata	Portinholas dos Canhões
18	264	1mm	3239L-2	Geschutspoorten	Puertecilla de cañón	Portello di murata	Portinholas dos Canhões
28	265	1mm	3239L-1	Geschutspoorten	Puertecilla de cañón	Portello di murata	Portinholas dos Canhões
4	266	1mm	3239L-2	Geschutspoorten	Puertecilla de cañón	Portello di murata	Portinholas dos Canhões
4	267	1mm	3239L-2	Geschutspoorten	Puertecilla de cañón	Portello di murata	Portinholas dos Canhões
4	268	1mm	3239L-2	Geschutspoorten	Puertecilla de cañón	Portello di murata	Portinholas dos Canhões
156	269	1mm	3239L-2	Puttings	Cadenote	Landra	Fixador do ovém
32	270	1mm	3239L-2	Sieraad	Adorno	Decorazioni	Adorno
4	271	1mm	3239L-1	Sieraad	Adorno	Decorazioni	Adorno
24	272	1mm	3239L-1	Sieraad	Adorno	Decorazioni	Adorno
2	273	1mm	3239L-2	Sieraad	Adorno	Decorazioni	Adorno
1	274	2mm	3240L-2	Dek	Cubierta	Ponte	Convés
4	275	3mm	3241L	Vulstukken	Trozo de ayuda	Pezzo ausiliario	Peças auxiliares
4	276	1mm	3239L-2	Kanon	Cañón	Cannone	Canhão
2	277	2mm	3240L-1	Kanon	Cañón	Cannone	Canhão
2	278	2mm	3240L-1	Kanon	Cañón	Cannone	Canhão
2	279	2mm	3240L-1	Kanon	Cañón	Cannone	Canhão

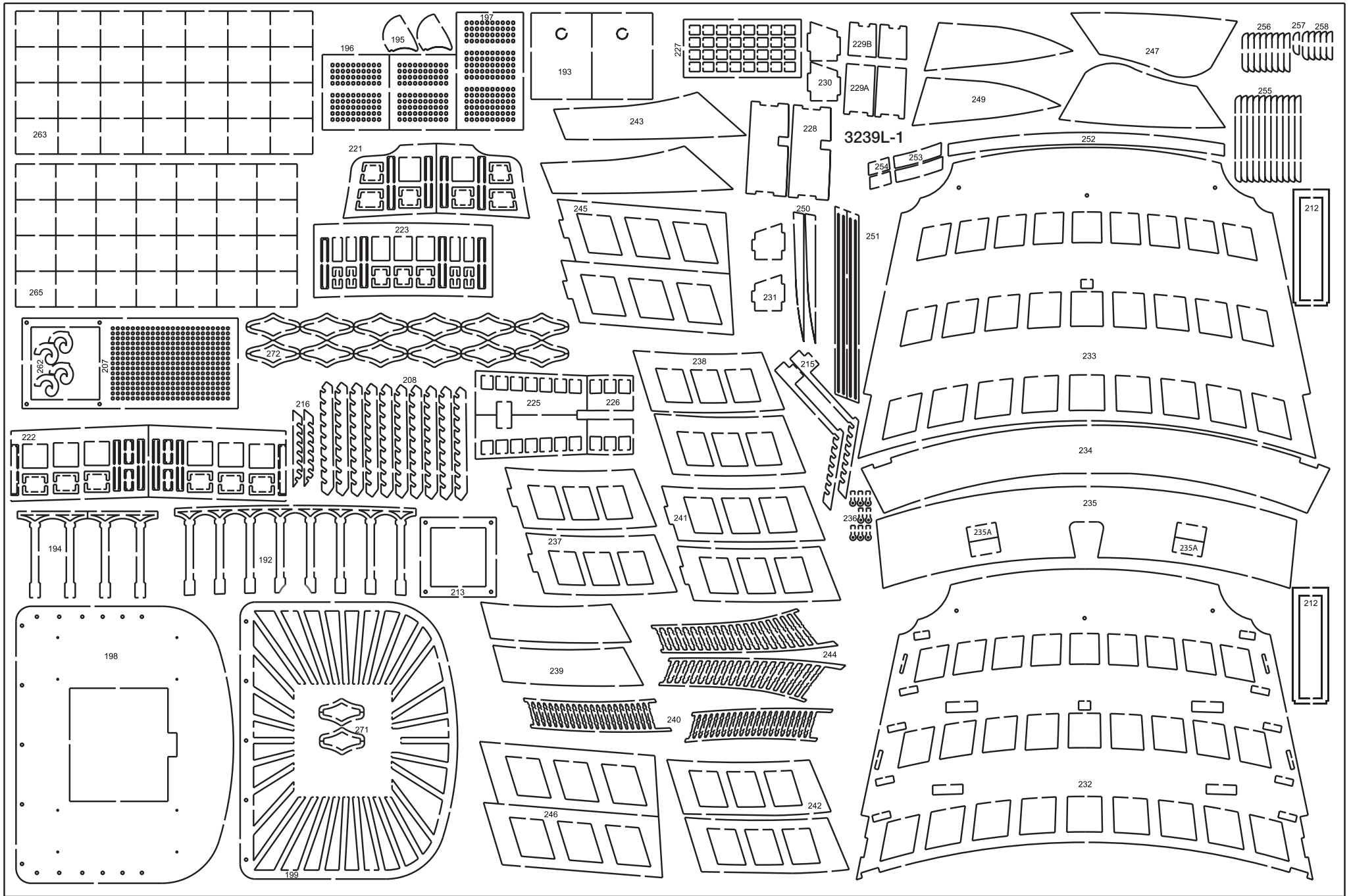
2	280	1mm	3239L-5	Kanon	Cañón	Cannone	Canhão
1	281	3mm	3241L	Kompashuis	Casa nocturna	Bussola	Suporte da bússola
3	282	1mm	3239L-5	deel voor Boegspriet	parte de Bauprés	parte di Bompresso	parte para gurupés
18	283	1mm	3239L-5	Mastbeslag	Herrajes de palo	Accessori albero	Braçadeira do mastro
1	284	1mm	3239L-5	Sieraad	Adorno	Decorazioni	Adorno
1	285	1mm	3239L-5	Sieraad	Adorno	Decorazioni	Adorno
1	286	1mm	3239L-5	Naambord	Placa del fabricante	Targhetta	Placa de identificação
1	287	1mm	3239L-5	Sieraad	Adorno	Decorazioni	Adorno
1	288	1mm	3239L-5	Sieraad	Adorno	Decorazioni	Adorno
1	289	1mm	3239L-5	Sieraad	Adorno	Decorazioni	Adorno
2	325	1mm	3239L-5	Nachthuis	Casa nocturna	Bussola	Suporte da bússola
2	326	1mm	3239L-5	Nachthuis	Casa nocturna	Bussola	Suporte da bússola
1	327	1mm	3239L-5	Nachthuis	Casa nocturna	Bussola	Suporte da bússola
4	328	1mm	3239L-5	Halter	Consola	Consolle	Suporte
	290-324			Mast, Stengen	Mast, Stengen	Alberi, Pennoni	Mastros, Vergas
	329-332			Mast, Stengen	Mast, Stengen	Alberi, Pennoni	Mastros, Vergas
3		Ø3x300MM		Rondhout	Barra reronda	Tondino (listello)	Bastão cilíndrico
2		Ø3x200MM		Rondhout	Barra reronda	Tondino (listello)	Bastão cilíndrico
1		Ø4x160MM		Rondhout	Barra reronda	Tondino (listello)	Bastão cilíndrico
1		Ø4x190MM		Rondhout	Barra reronda	Tondino (listello)	Bastão cilíndrico
2		Ø4x200MM		Rondhout	Barra reronda	Tondino (listello)	Bastão cilíndrico
2		Ø4x210MM		Rondhout	Barra reronda	Tondino (listello)	Bastão cilíndrico
1		Ø4x240MM		Rondhout	Barra reronda	Tondino (listello)	Bastão cilíndrico
1		Ø4x250MM		Rondhout	Barra reronda	Tondino (listello)	Bastão cilíndrico
1		Ø4x260MM		Rondhout	Barra reronda	Tondino (listello)	Bastão cilíndrico
1		Ø4x300MM		Rondhout	Barra reronda	Tondino (listello)	Bastão cilíndrico
2		Ø4x400MM		Rondhout	Barra reronda	Tondino (listello)	Bastão cilíndrico
6		Ø6x300MM		Rondhout	Barra reronda	Tondino (listello)	Bastão cilíndrico
3		Ø6x250MM		Rondhout	Barra reronda	Tondino (listello)	Bastão cilíndrico
2		Ø8x400MM		Rondhout	Barra reronda	Tondino (listello)	Bastão cilíndrico
1		Ø8x260MM		Rondhout	Barra reronda	Tondino (listello)	Bastão cilíndrico
3		Ø12x350MM		Rondhout	Barra reronda	Tondino (listello)	Bastão cilíndrico
2		1,8x2x650	Obechi	Strip	Listón	Listello	Tira
2		1,8x4x650	Obechi	Strip	Listón	Listello	Tira

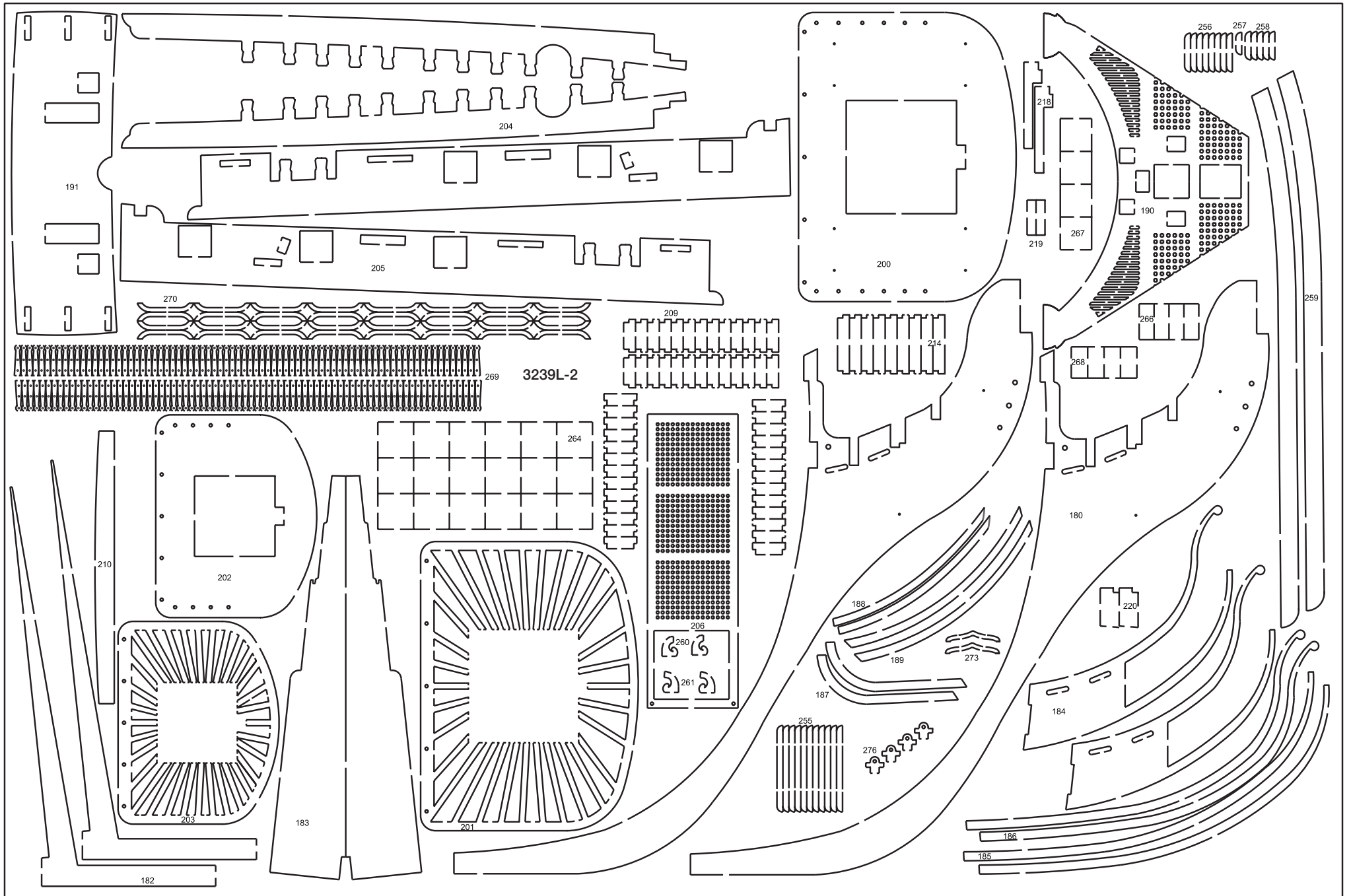
10		1,5x3x500	Pine	Strip	Listón	Listello	Tira
1		1,8x2x550	Pine	Strip	Listón	Listello	Tira
72		0,7x4x550	Annegre	Strip	Listón	Listello	Tira
1		3x3x500	Basswood	Strip	Listón	Listello	Tira
80		1,8x7x820	Obechi	Strip	Listón	Listello	Tira
28	F10	40mm	Brass	Puttings	Cadenote	Landra	Fixador do ovém
18	F39	25cm	Brass	Messingdraad	Hilo de latón	Filo in ottone	Fio de latão
1	F70	100m		Takelgaren	Takelgaren	Filo per manovre	Linha de cordame
1	F71	100m		Takelgaren	Takelgaren	Filo per manovre	Linha de cordame
3	F72	30m		Takelgaren	Takelgaren	Filo per manovre	Linha de cordame
1	F73	6m		Takelgaren	Takelgaren	Filo per manovre	Linha de cordame
1	F74	0,7m		Takelgaren	Takelgaren	Filo per manovre	Linha de cordame
60	F54	8mm	Brass	Korvijnnagel	Cabillas	Ribattino	Pino de amarracão
1	F56	ø5x5,5mm	Brass	Scheepbel	Campanilla	Campana	Sino
88	F81	18mm	Brass	Kanon	Cañon	Cannone	Canhão
4	F120	ø16mm	Brass/plastic	Bordlichten	Linternas	Lanterne	Luzes
18	F163	40mm	Brass	Kanon	Cañon	Cannone	Canhão
5	F164		Plastic	Kanonwagen	Cureña	Affusto	Carro
4	F224	12mm	Brass	Railingpalen	Barandilla	Supporti per corrimano	Pontaletes da amurada
12	F285	5,5mm	Brass	Oogbauten	Pernos de cánamo	Bullone ad occhio	Ferrolho
0,2	F327	2x1,5mm	Brass	Ketting	Cadena de ancla	Catena ancora	Corrente da âncora
1	F409	ø1,5x250mm	Brass	Messingdraad	Hilo de latón	Filo in ottone	Fio de latão
26	F488	ø3mm		Perle	Perla	Perla	Luz de alerta (pérola)
2	F490-1		Brass	Kanon	Cañon	Cannone	Canhão
20	F493	15mm	Brass	Railingpalen	Barandilla	Supporti per corrimano	Pontaletes da amurada
3	F502		Brass	Ring	Argolla	Anello	Anel
34	F537	25mm	Brass	Puttings	Cadenote	Landra	Fixador do ovém
42	F539	40mm	Brass	Puttings	Cadenote	Landra	Fixador do ovém
80	F664	11mm	Brass	Oogbauten	Pernos de cánamo	Bullone ad occhio	Ferrolho
112	F080	Ø5mm	Wood	Jufferblokken	Virgenes	Testa di montone	Bigota
112	F219	Ø7mm	Wood	Jufferblokken	Virgenes	Testa di montone	Bigota
84	F064-1	5mm	Wood	Enkel, blok	Polea, simple	Blocchi (semplici)	Blocos Simples
8	F681	5x5x7,5mm	Wood	Triple blok	Triple bloque	Triplo blocco	Triple bloco
18	F223	7mm	Wood	Dubbel, blok	Polea, doble	Blocchi (doppi)	Blocos Duplos

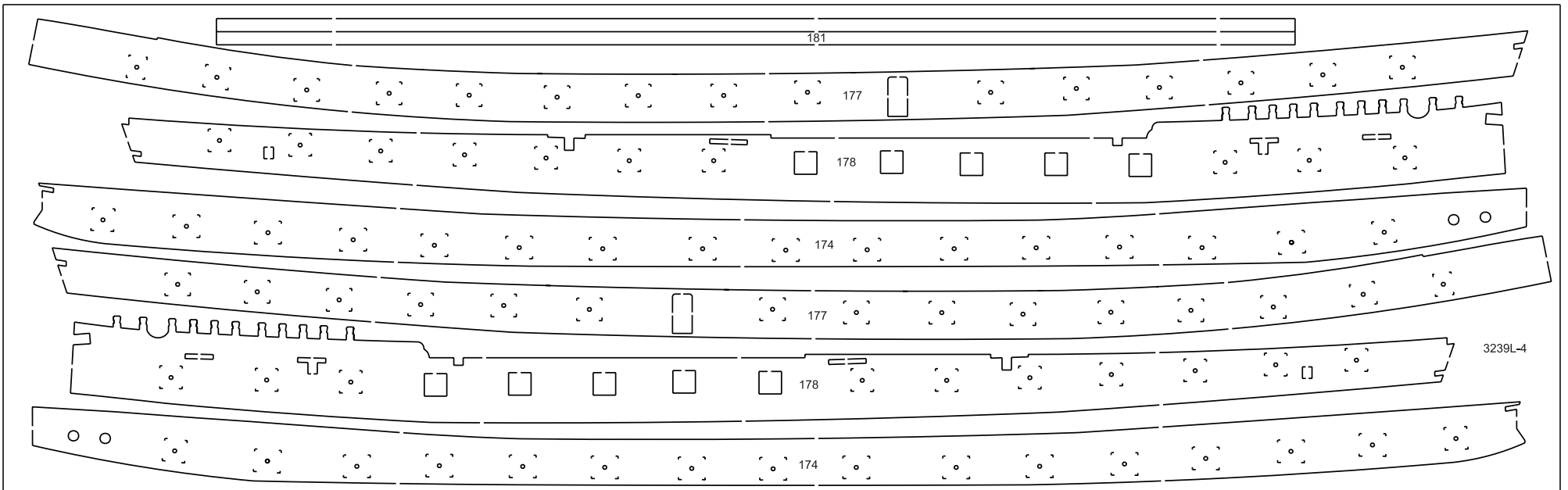
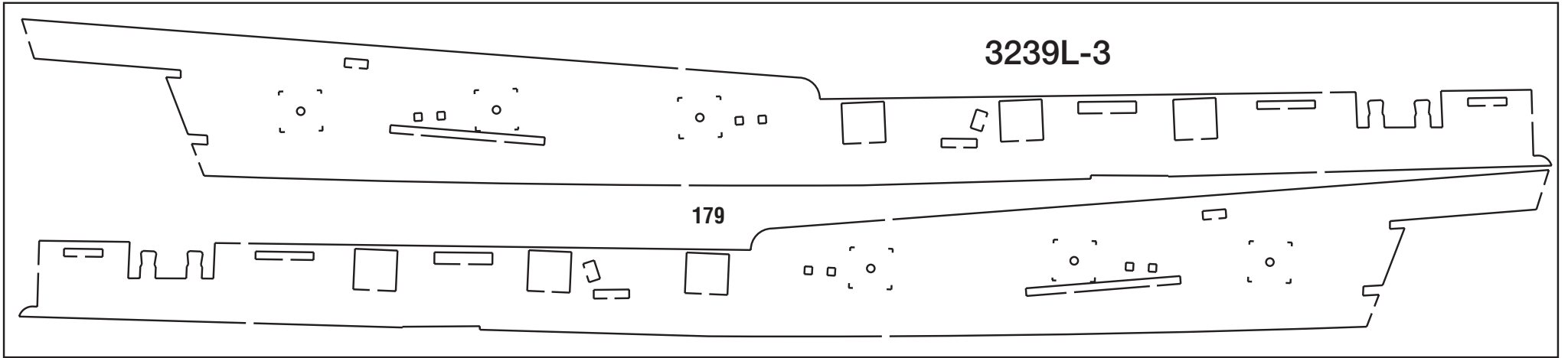
23	F767	4x2x2,5mm	Wood	Enkel, blok	Polea, simple	Blocchi (semplici)	Blocos Simples
2	F920	21mm	Brass	Stuurwiel	Volante	Ruota del timone	Volante do timão
4	F921	Ø2x8mm	Brass	buizen	Tubo	Tubi	Tubo
8	F922	Ø3x2mm	Brass	Ring	Argolla	Anello	Anel
8	F923	Ø4x2mm	Brass	Ring	Argolla	Anello	Anel
8	F924	Ø5x2mm	Brass	Ring	Argolla	Anello	Anel
4	F925	Ø6x2mm	Brass	Ring	Argolla	Anello	Anel
4	F926	Ø7x2mm	Brass	Ring	Argolla	Anello	Anel
8	F927	Ø9x2mm	Brass	Ring	Argolla	Anello	Anel
30	F928	Ø13x2mm	Brass	Ring	Argolla	Anello	Anel
1	F929	Ø4x4mm	Brass	buizen	Tubo	Tubi	Tubo
1	F930	Ø6x35mm	Brass	buizen	Tubo	Tubi	Tubo
2	F773	0,4x2,5x250mm	Brass	Band	cinta	Nastro	Fita
1	F932		Brass	Boegbeeld	Figurón de proa	Polena	Figura de proa e entalhes
1				Bouwbeschrijving	Instrucciones de construccion	Istruzioni di montaggio	Manual de instruções
1				Tekening 1+4	Ilustración 1+4	Piani di costruzione 1+4	Planta principal 1+4
1				Tekening 2+3	Ilustración 2+3	Piani di costruzione 2+3	Planta principal 2+3
1		Flag150		Vlag	Vlag	Bandiere	Bandeira
1			Acrylic	Raam	Ventanas	Finestrini	Janelas
1		300x600mm		Net/railing	Red/pasamanos	Rete/parapetto	Rede/amurada

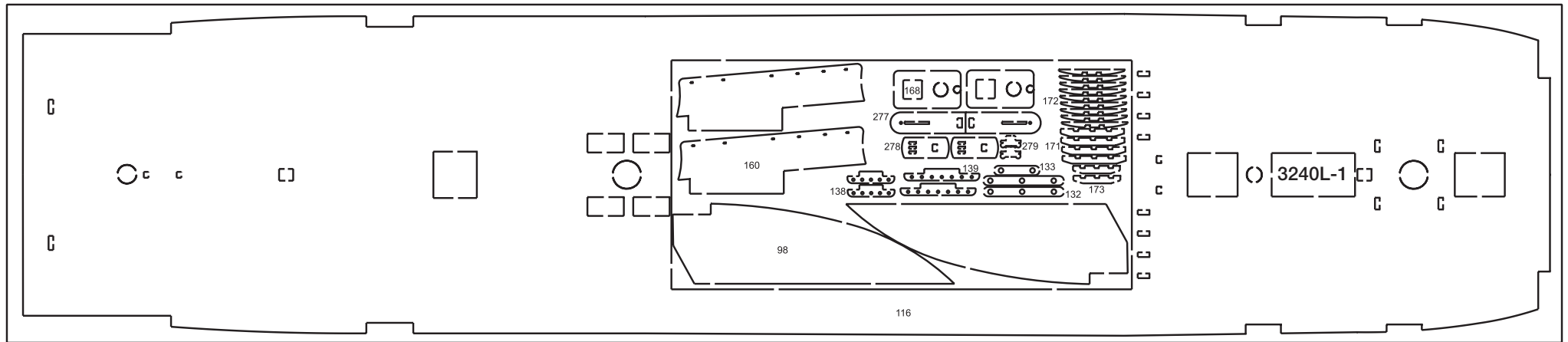
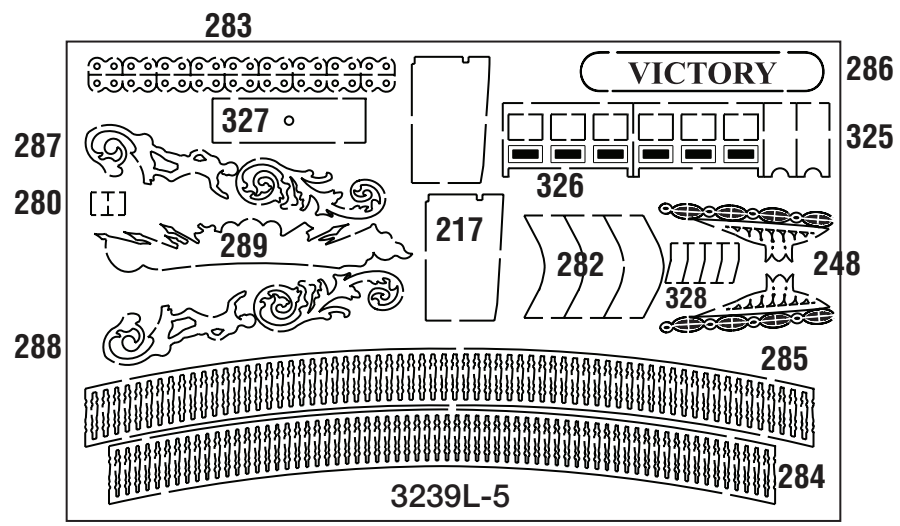












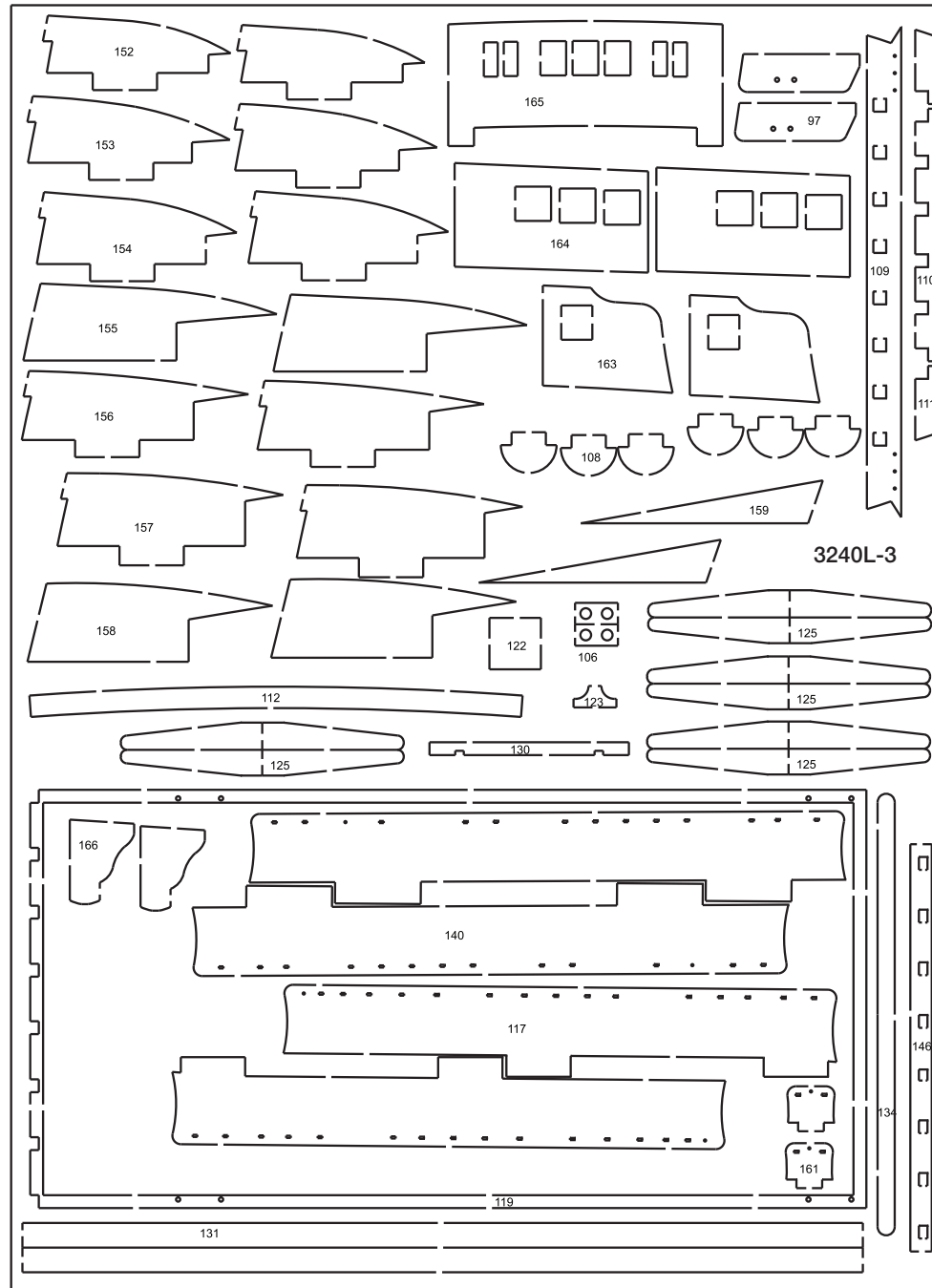


FIG 1

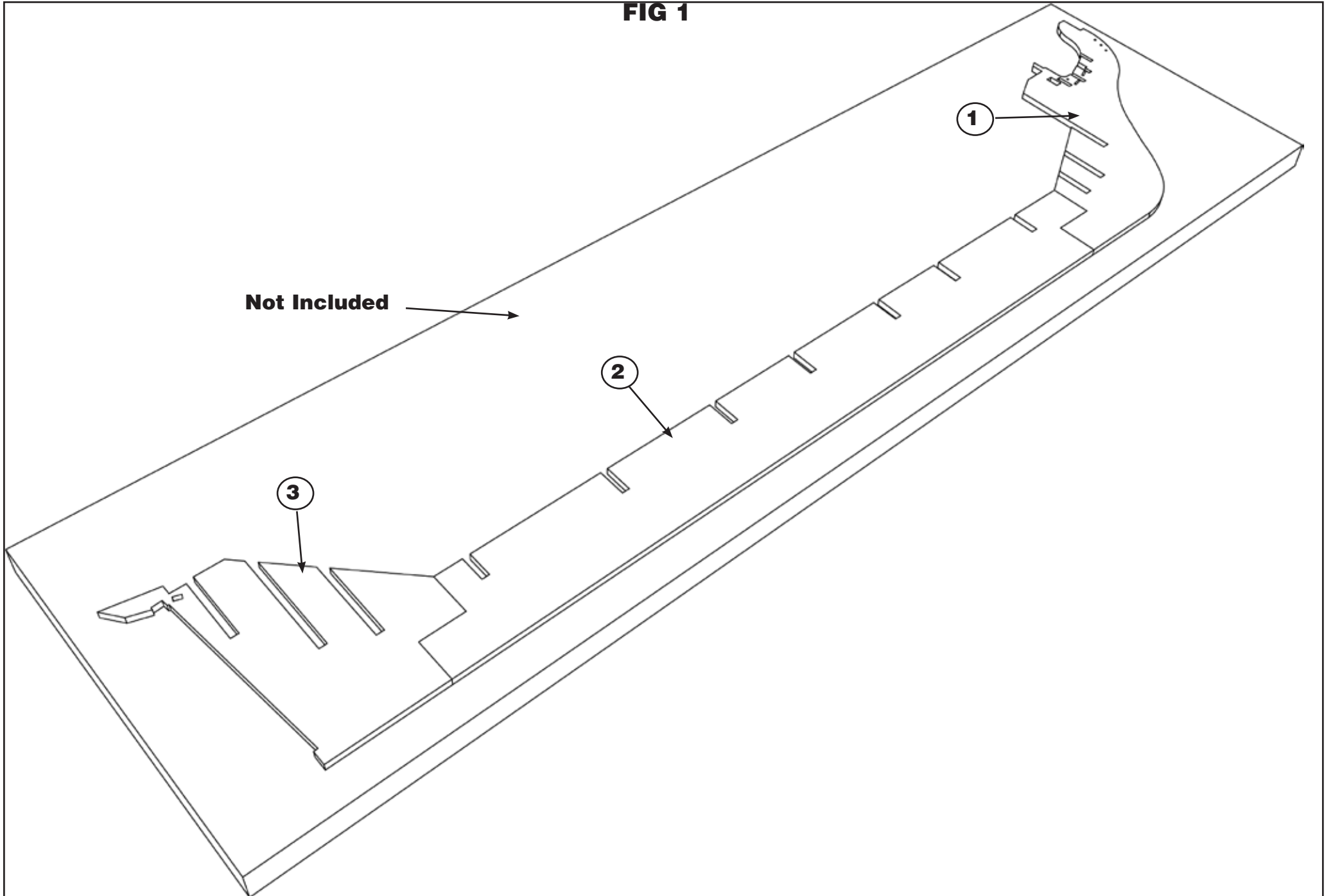


FIG 1A

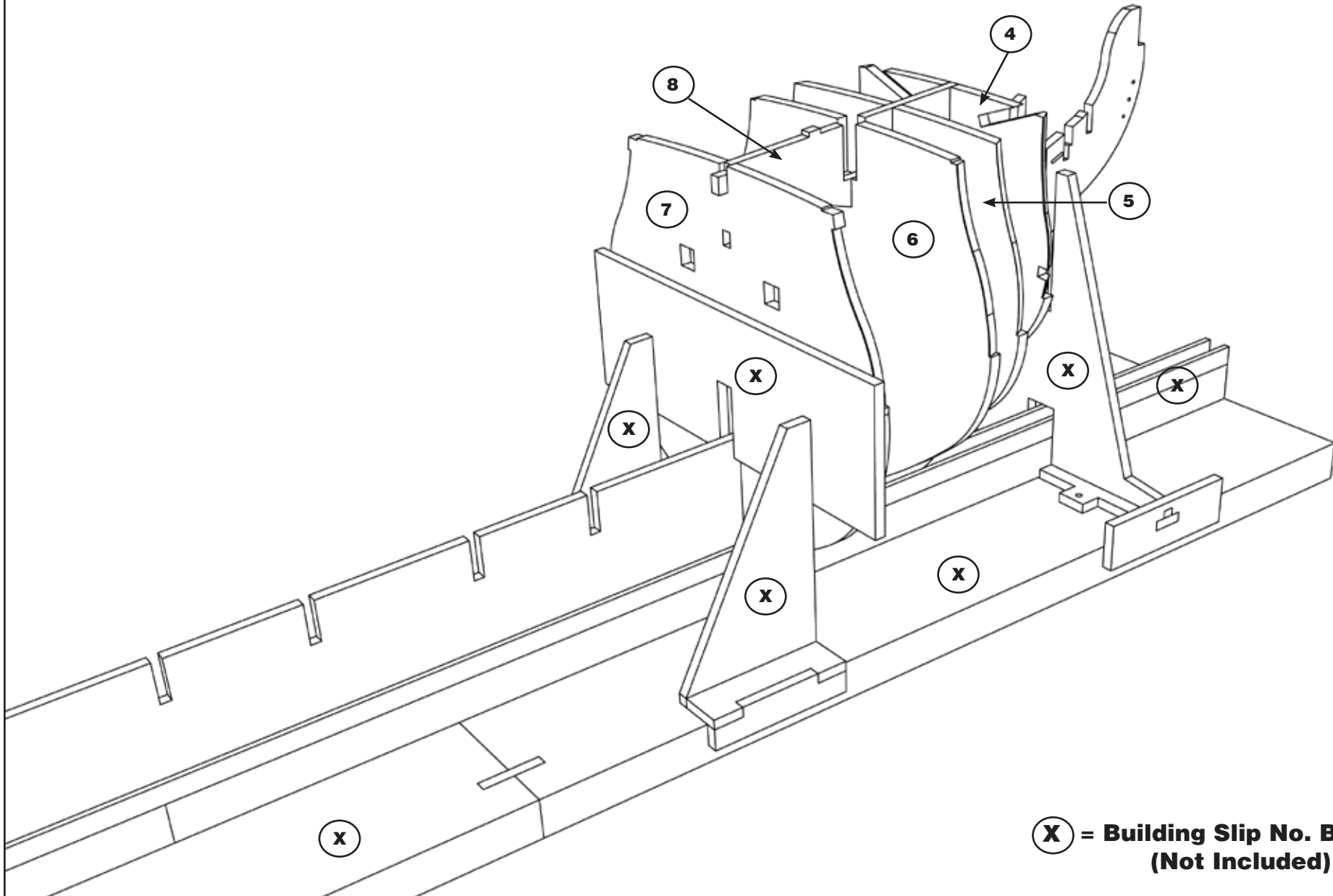
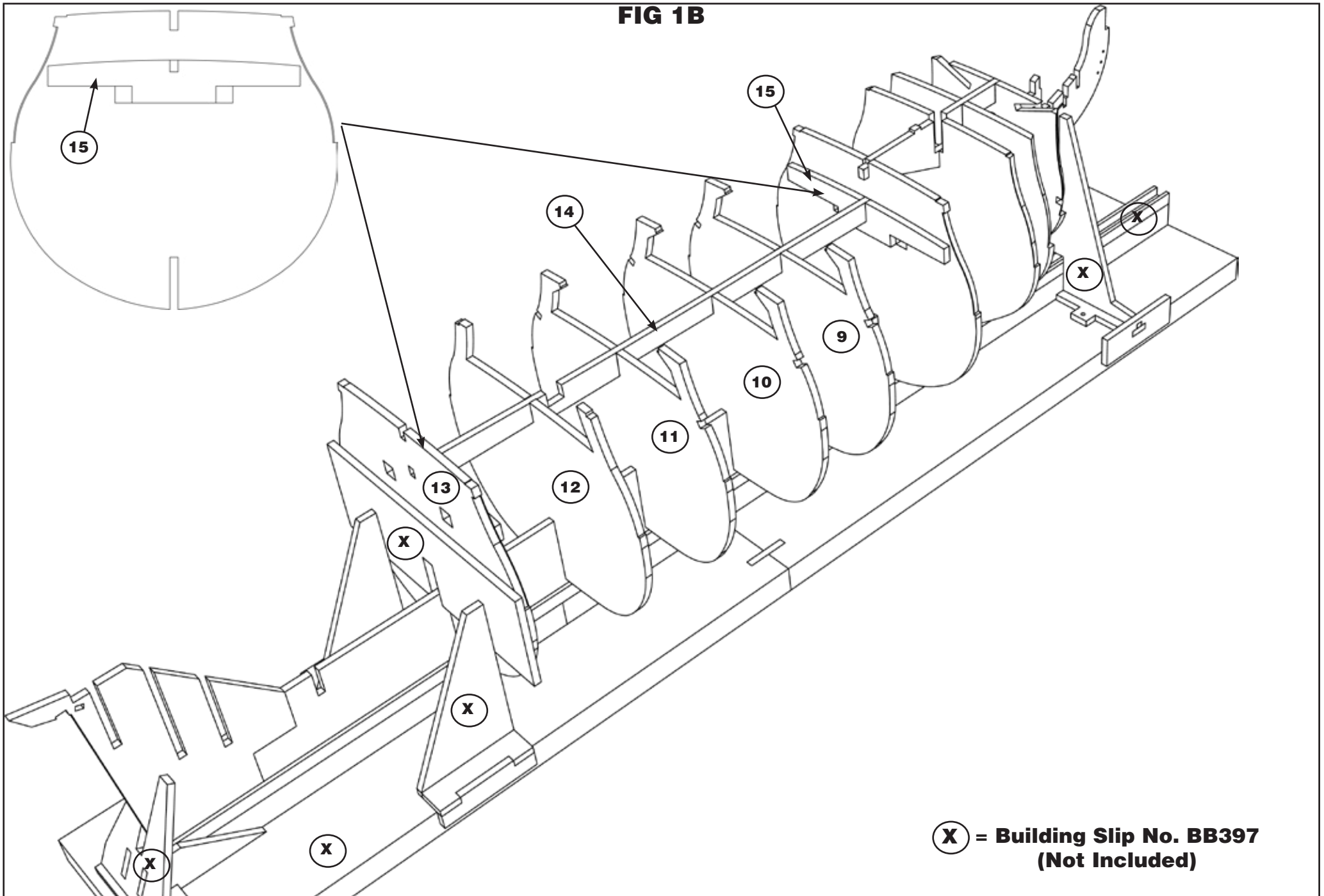


FIG 1B



**(X) = Building Slip No. BB397
(Not Included)**

FIG 2

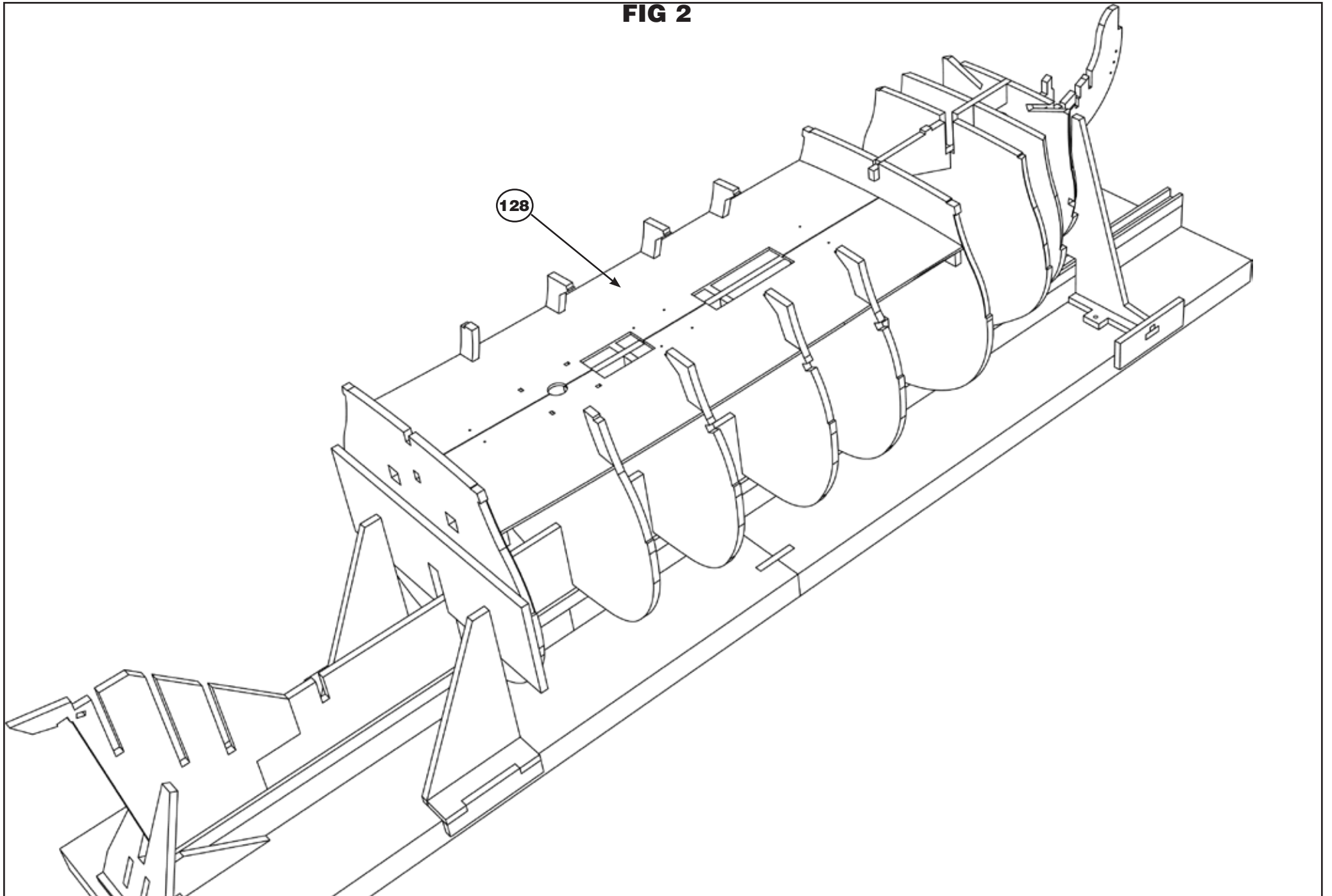


FIG 2A

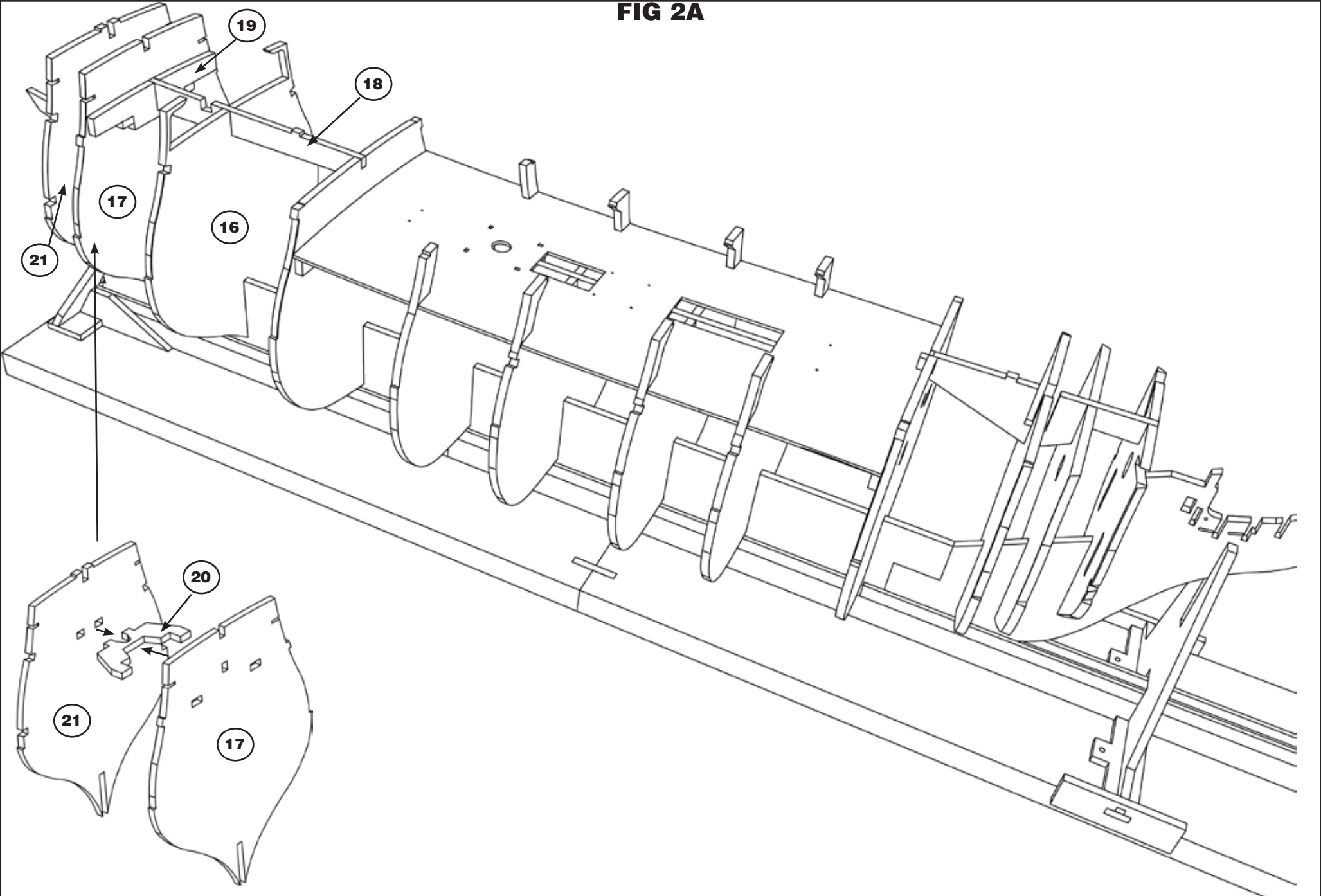


FIG 2B

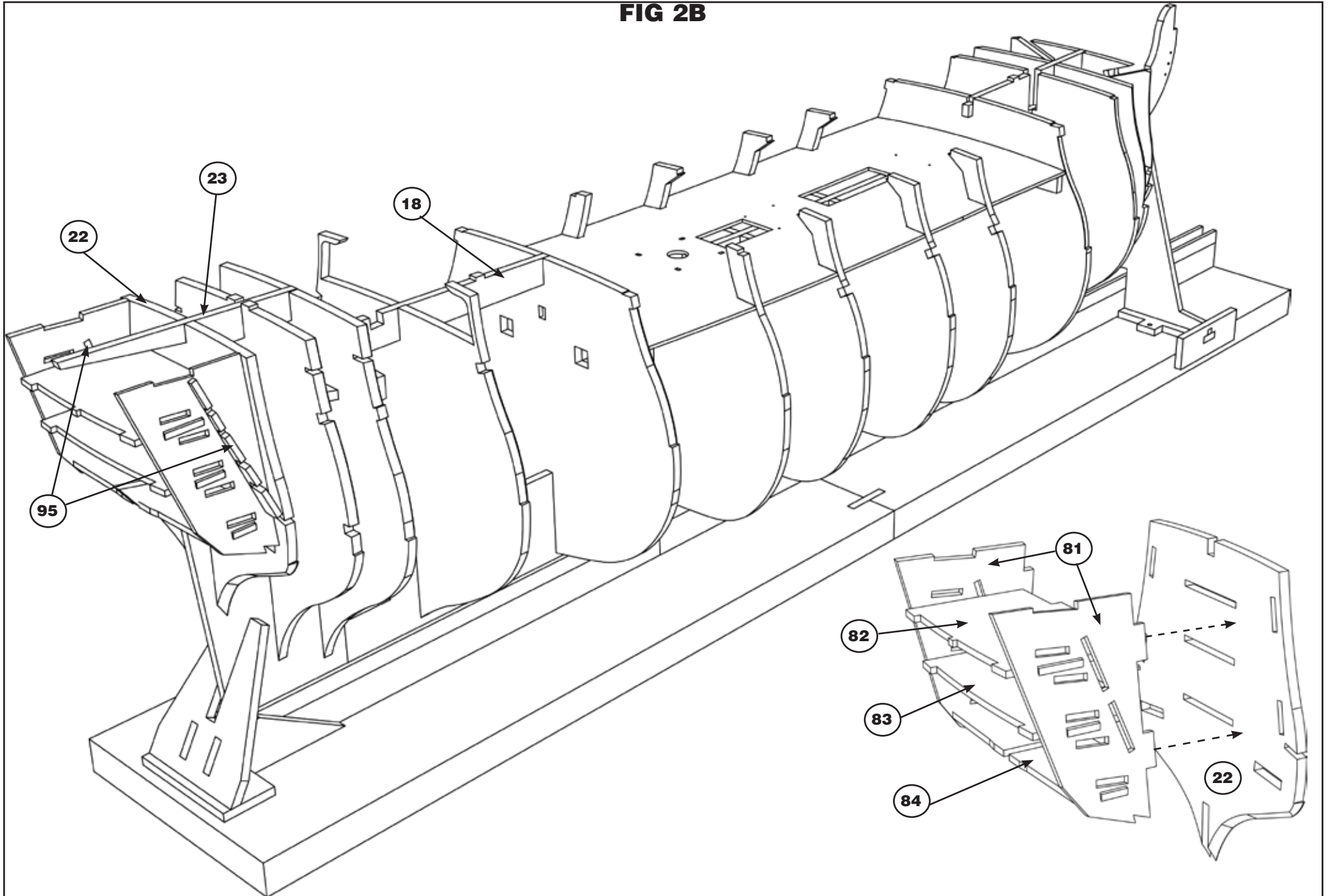


FIG 3

Deck 0,7x4mm

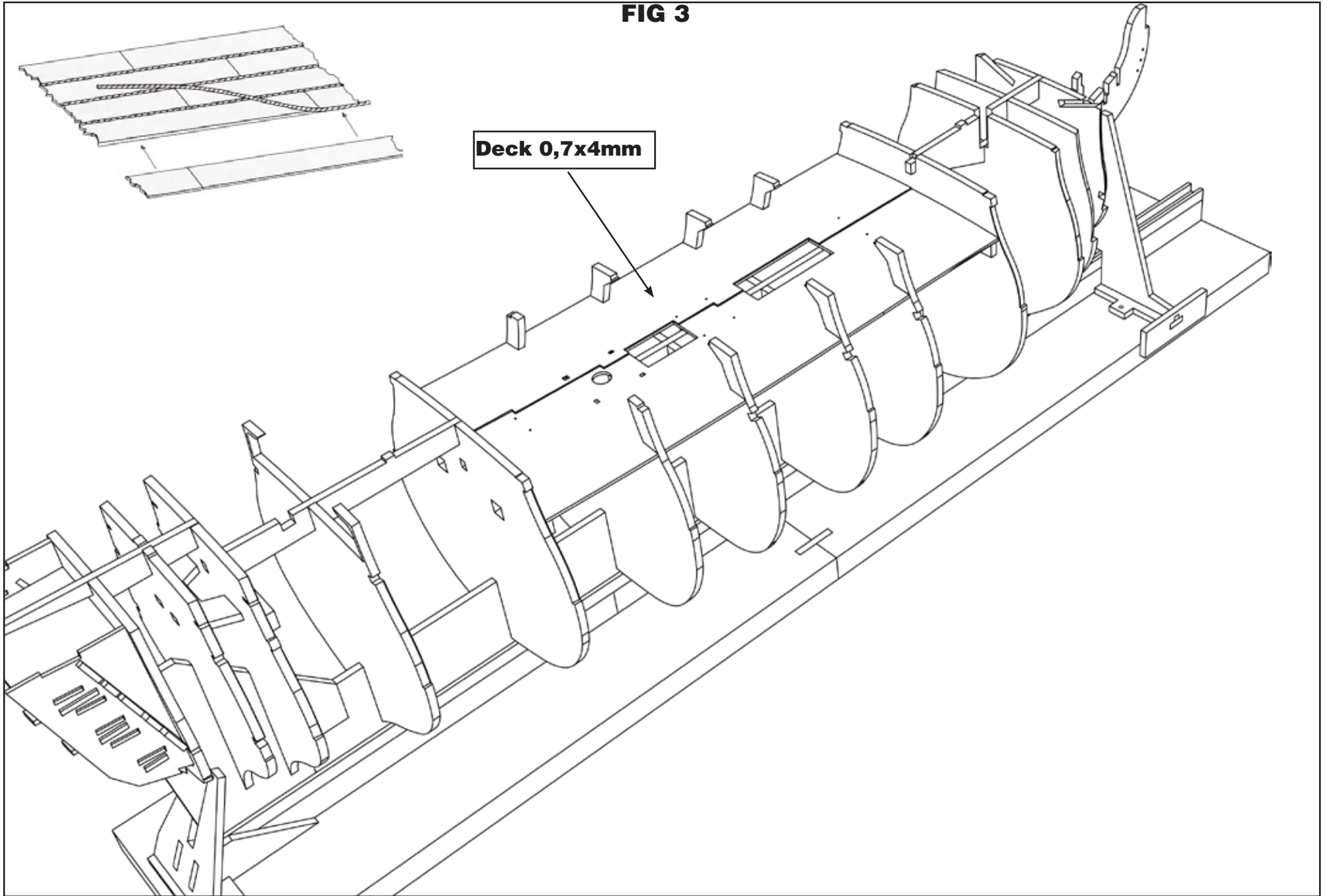


FIG 4

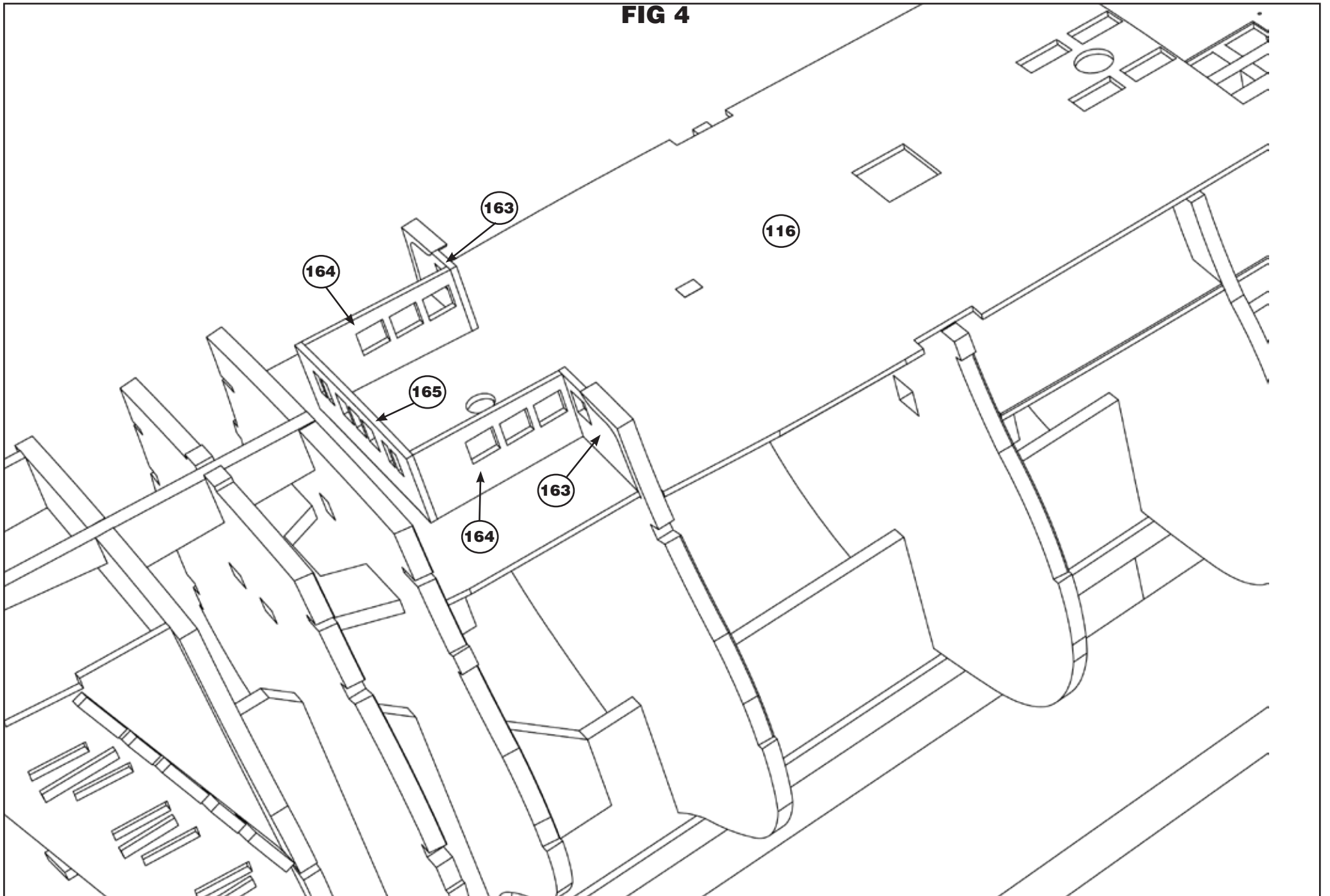


FIG 4A

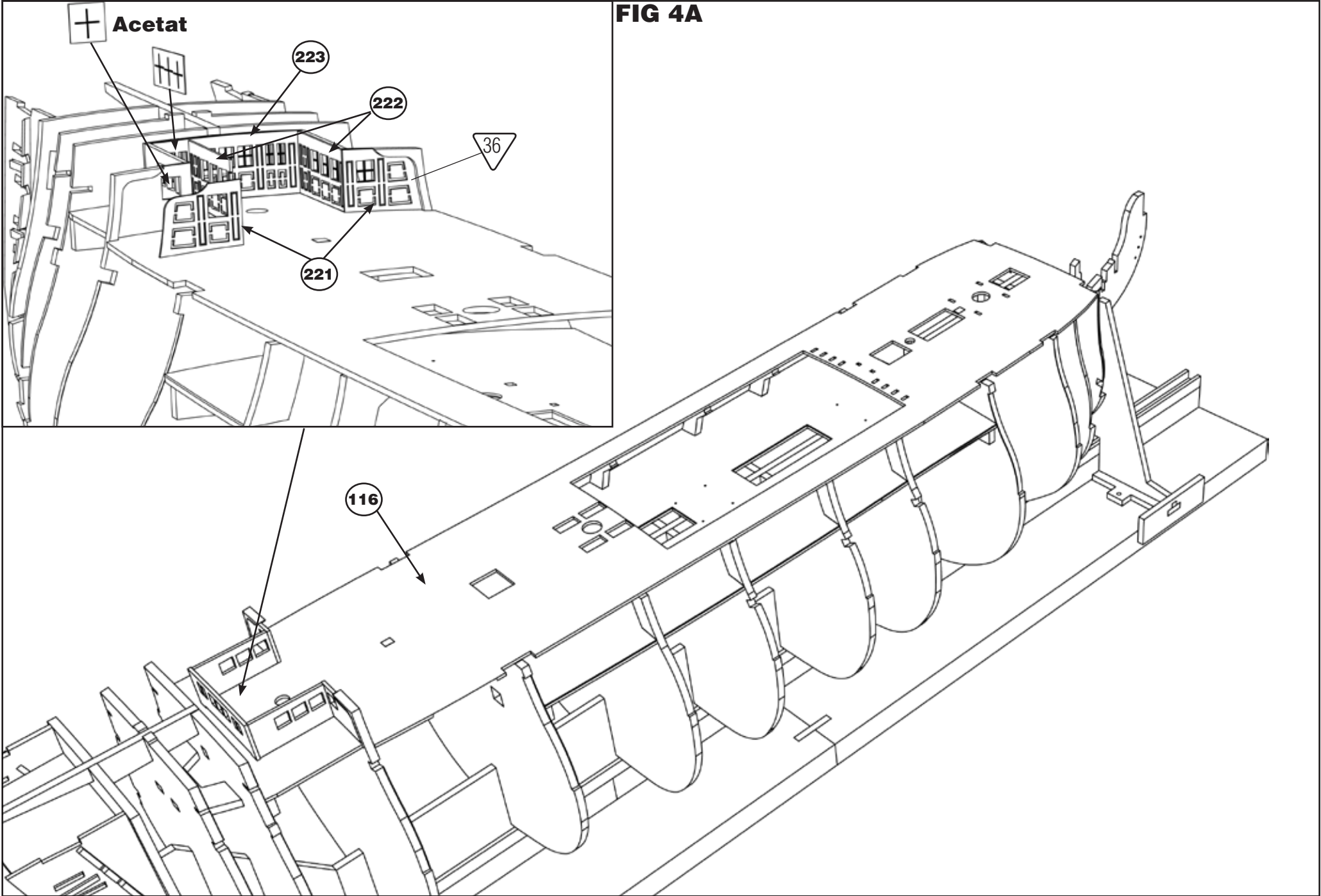


FIG 5

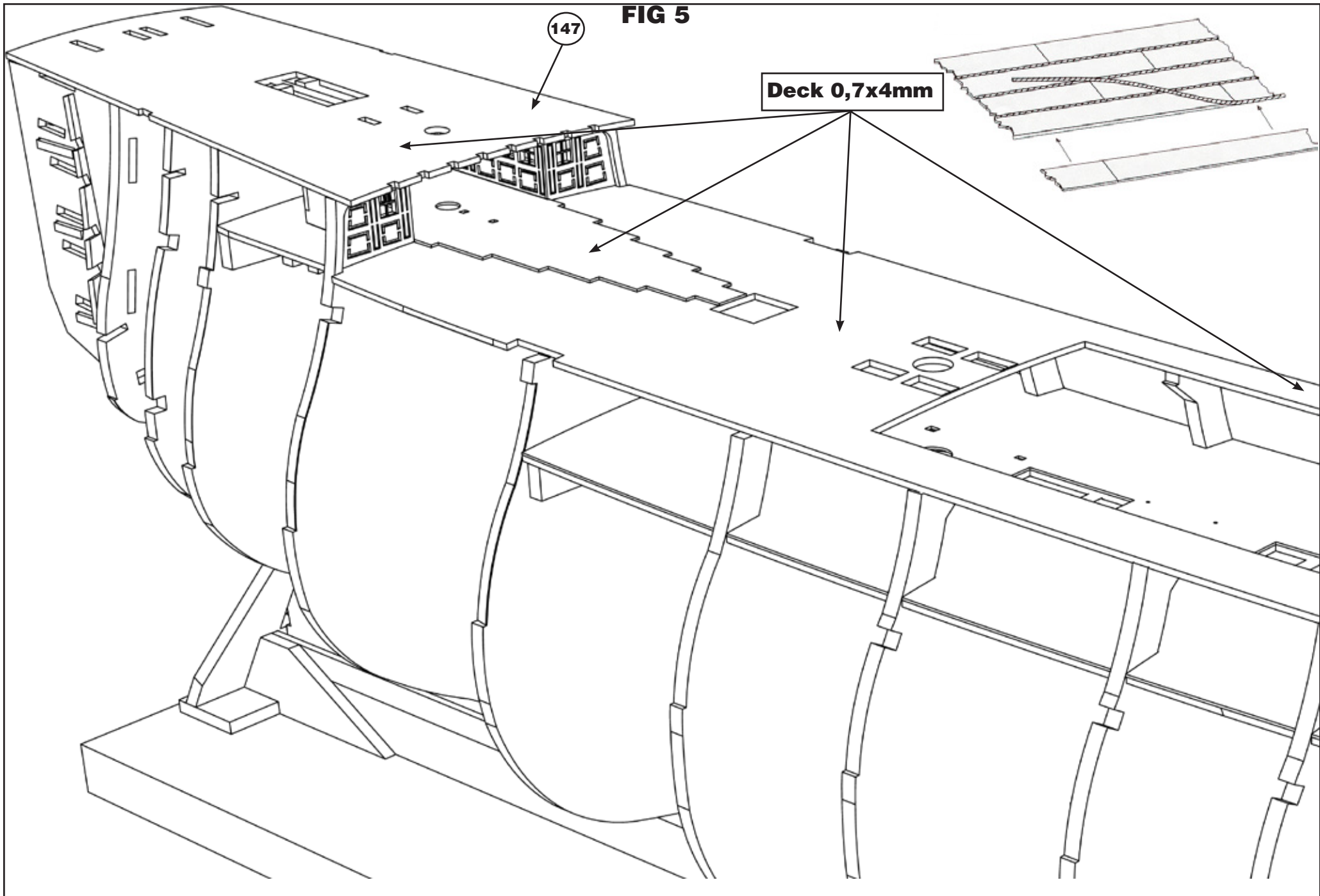


FIG 6

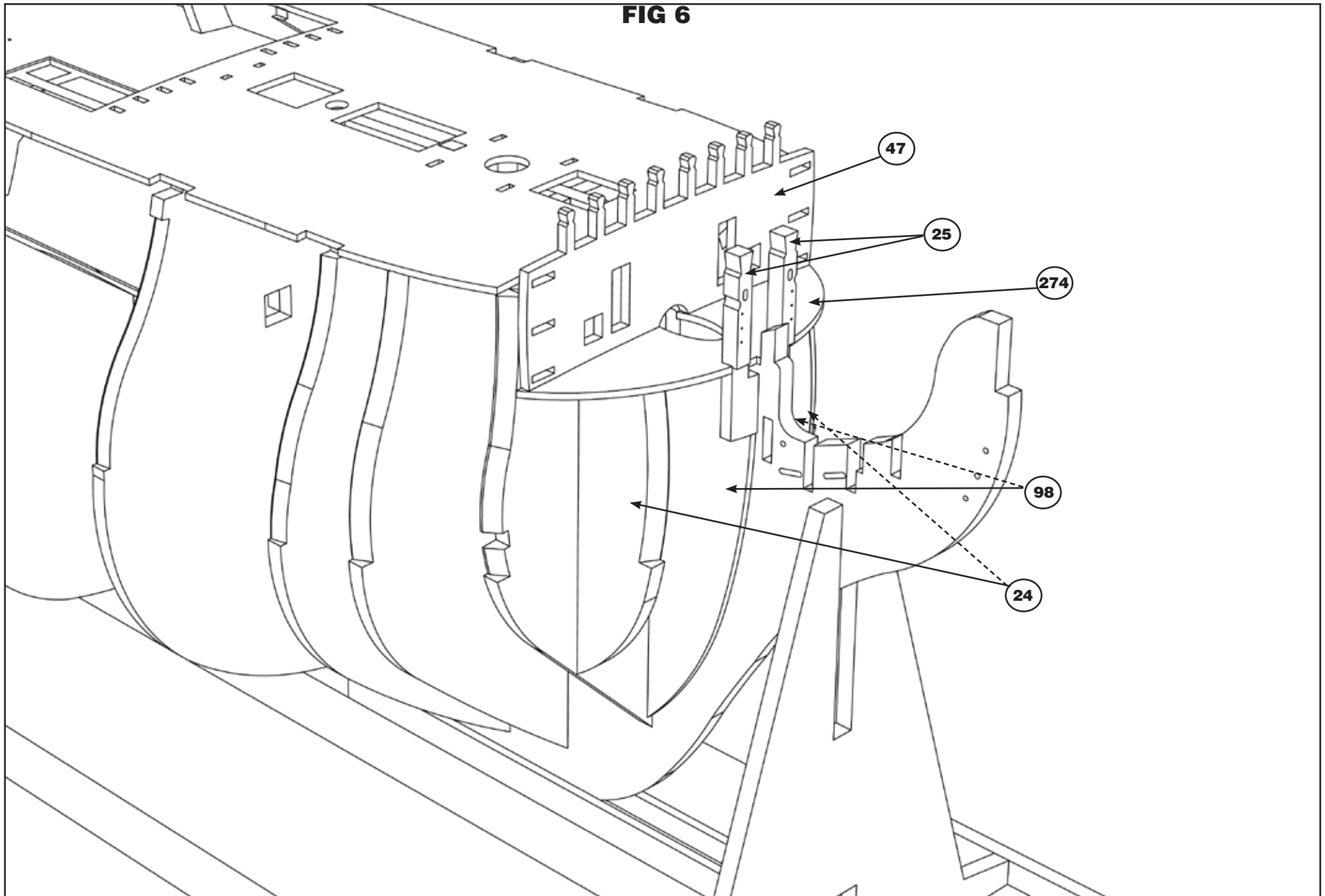
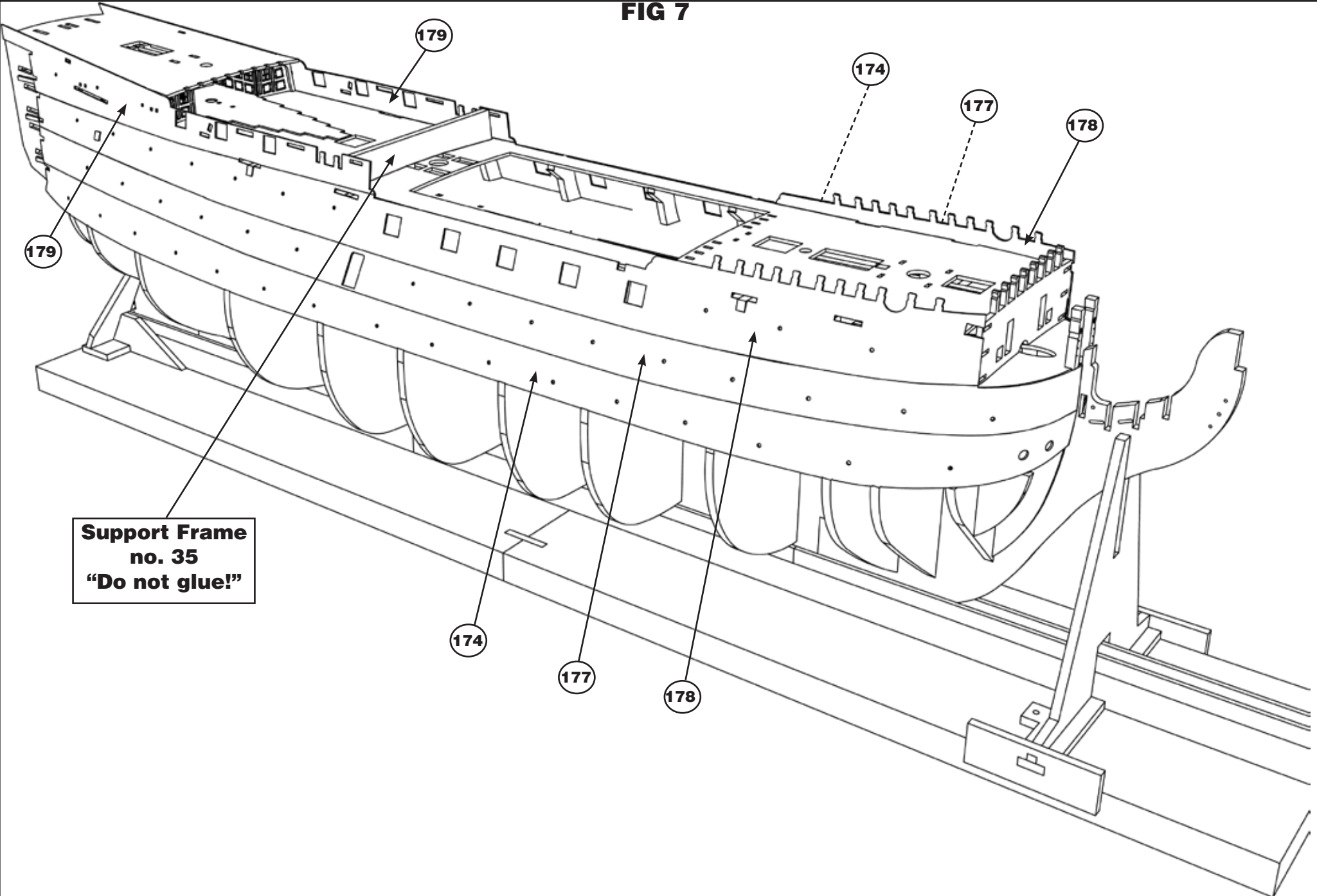


FIG 7



**Support Frame
no. 35
"Do not glue!"**

FIG 8

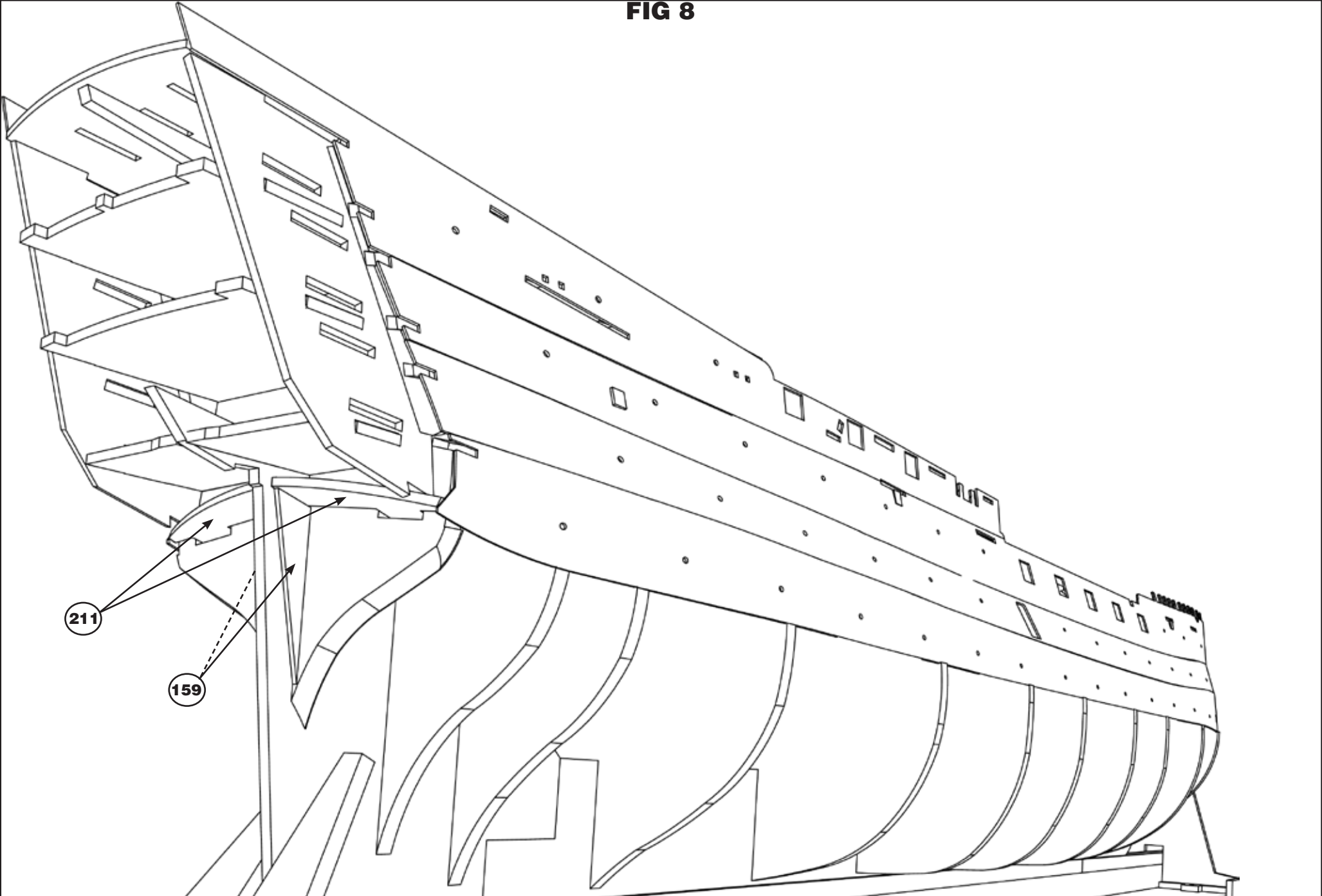


FIG 8A

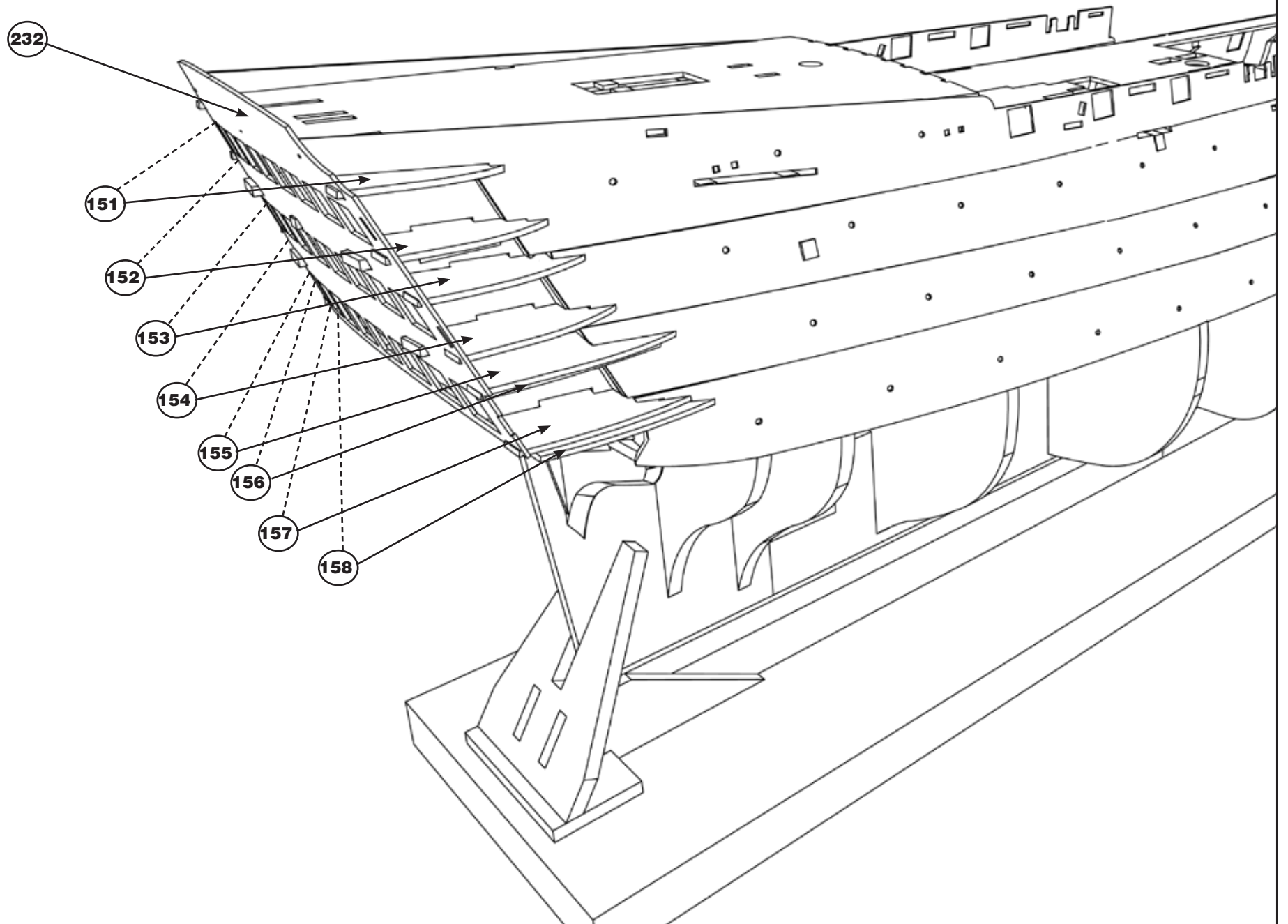


FIG 8B

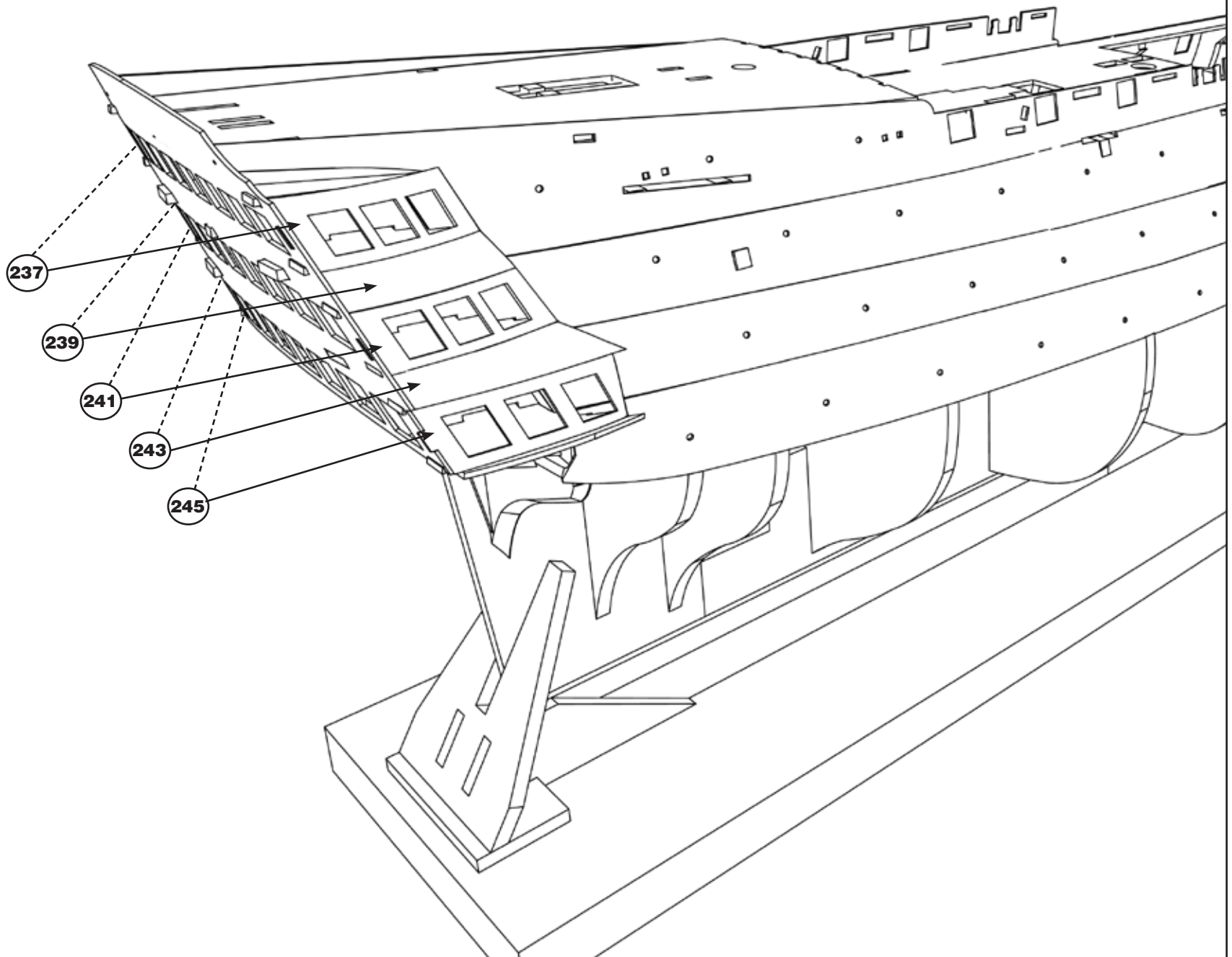


FIG 8C

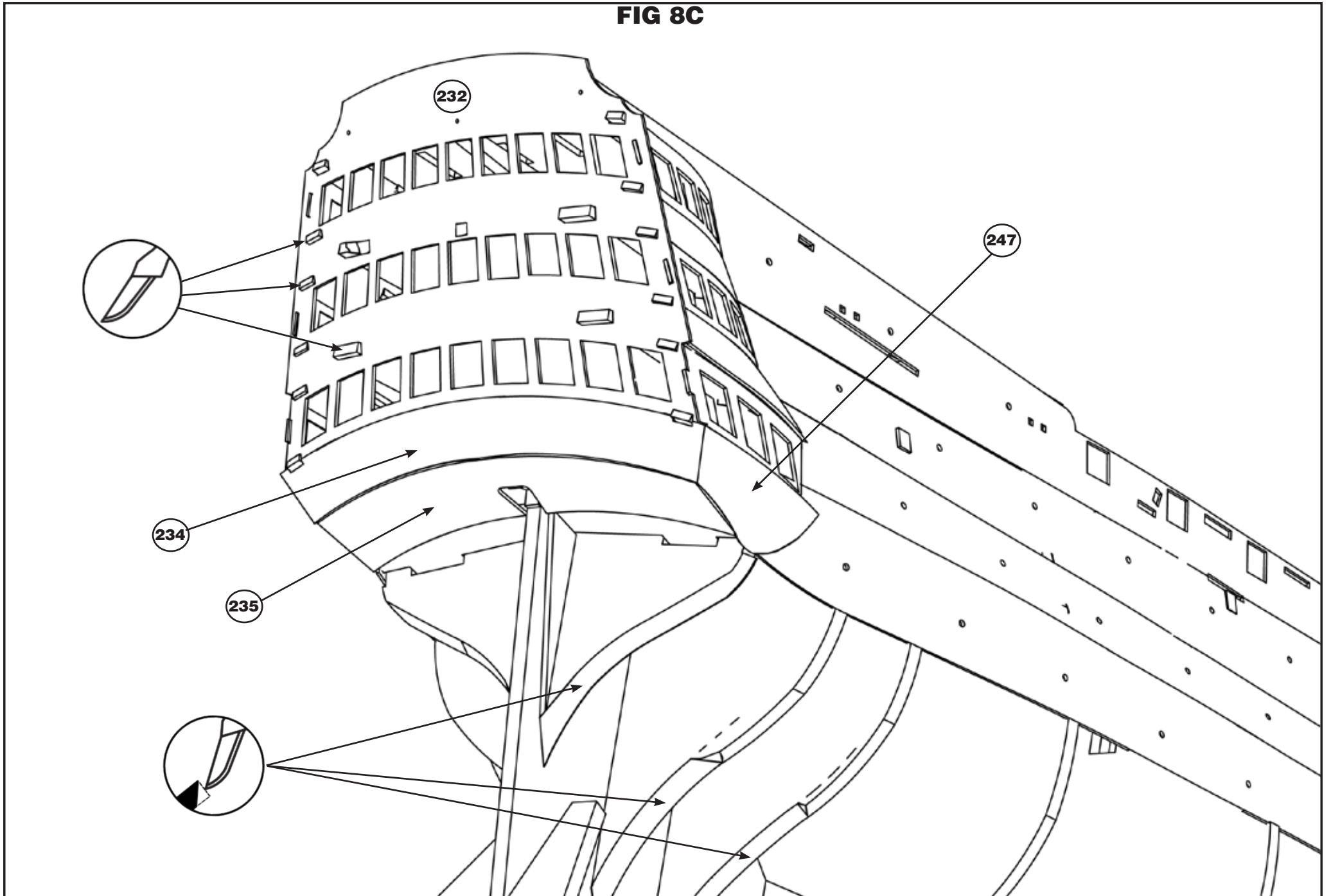


FIG 9

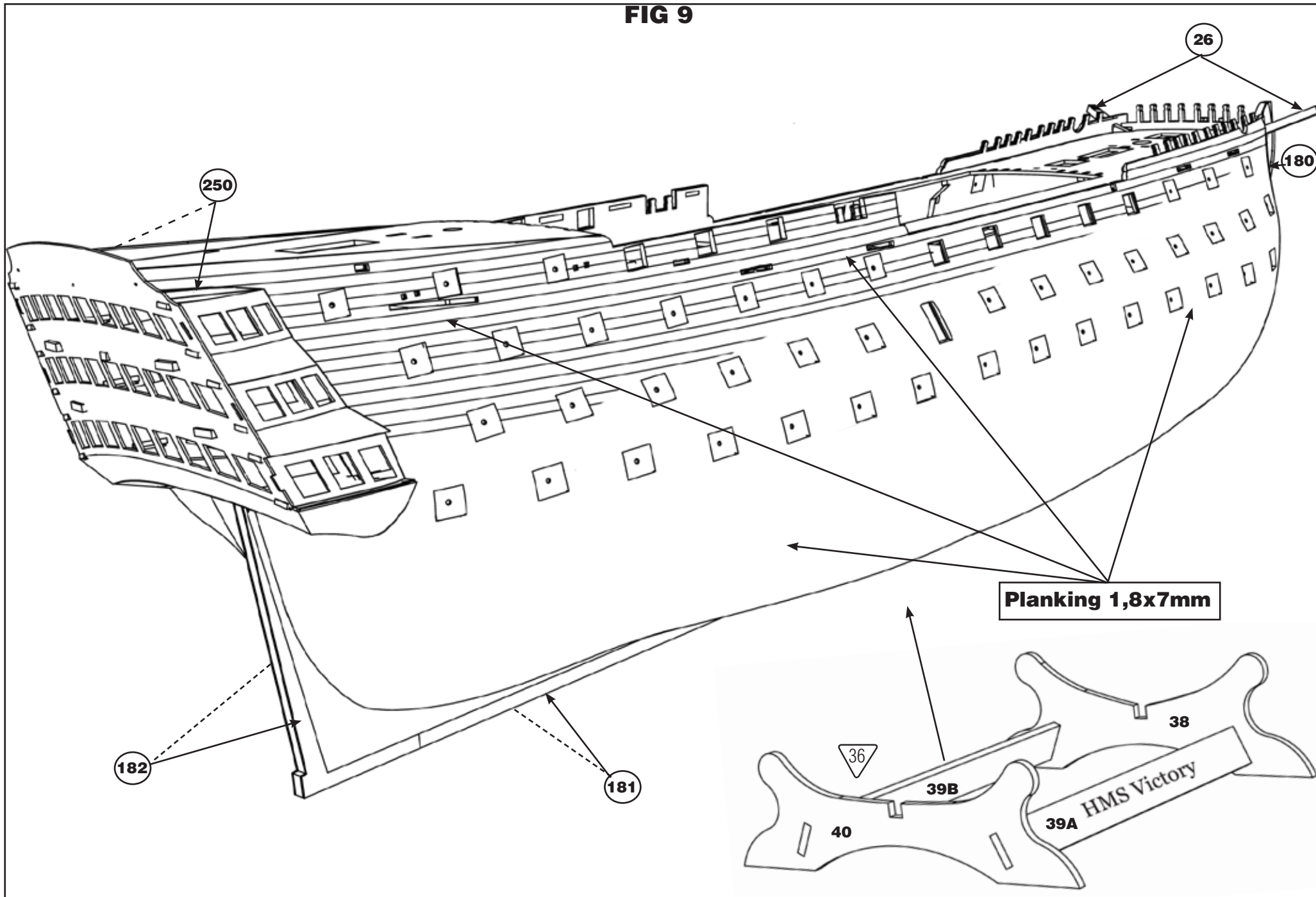


FIG 9A

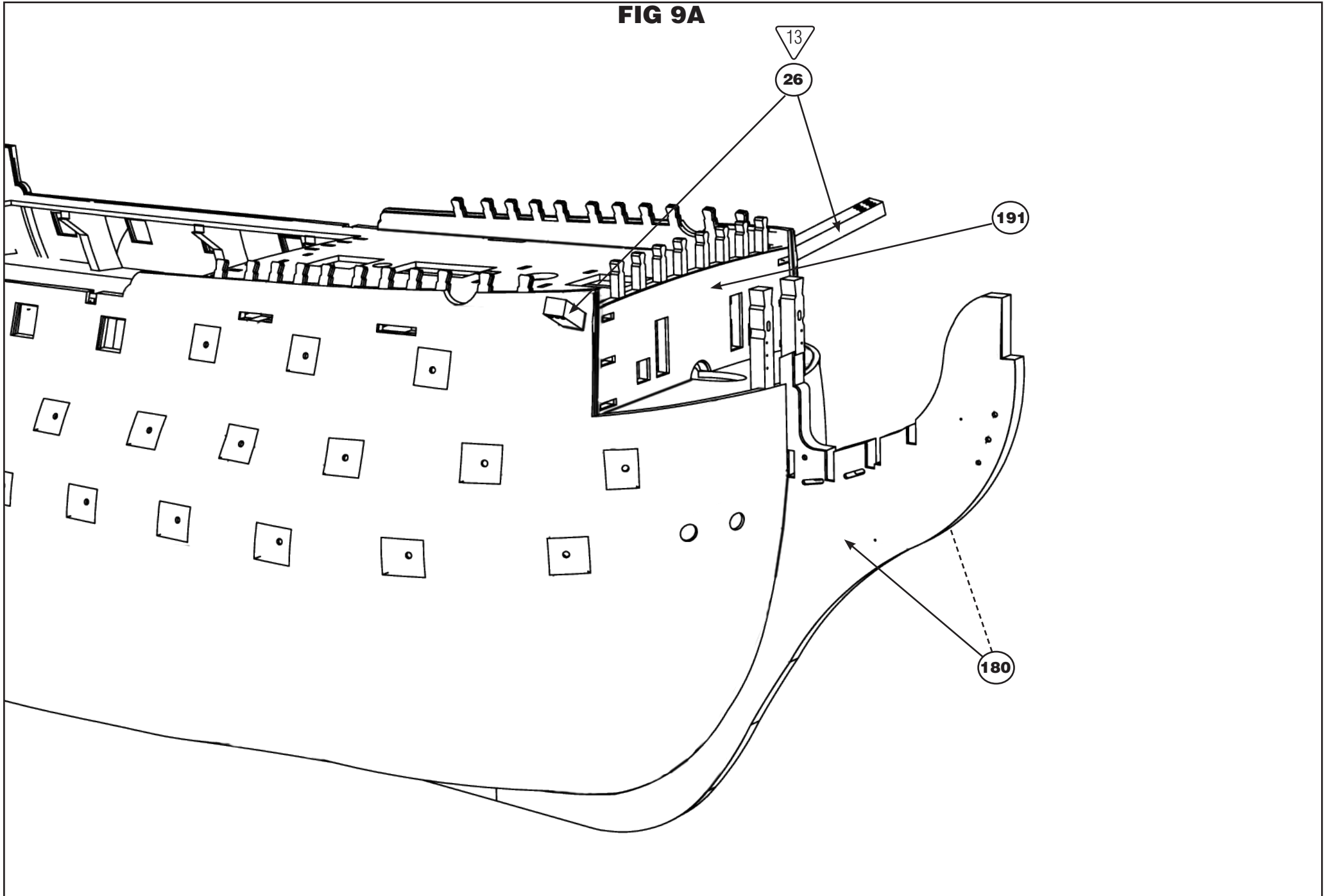


FIG 10

Acetate

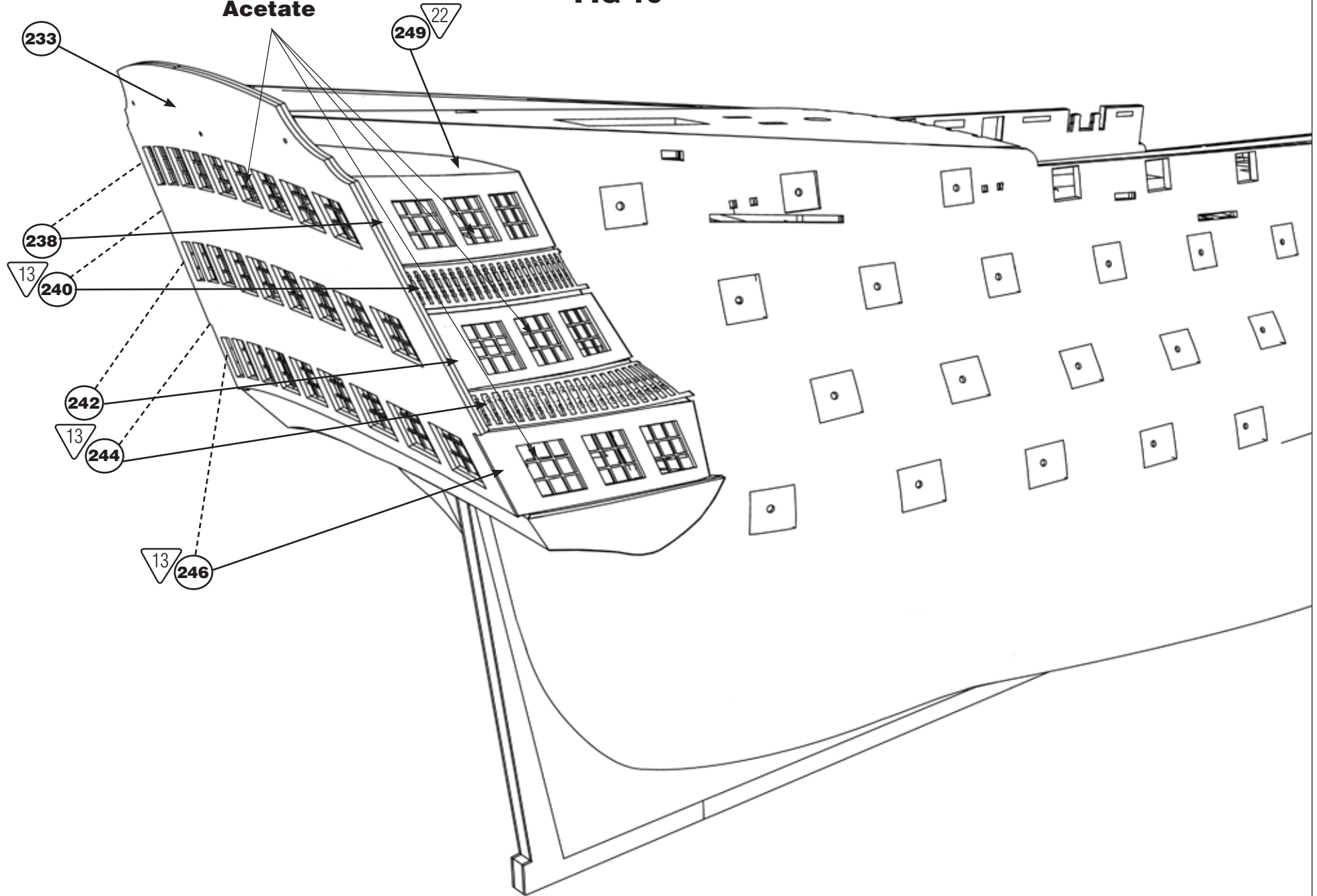


FIG 11

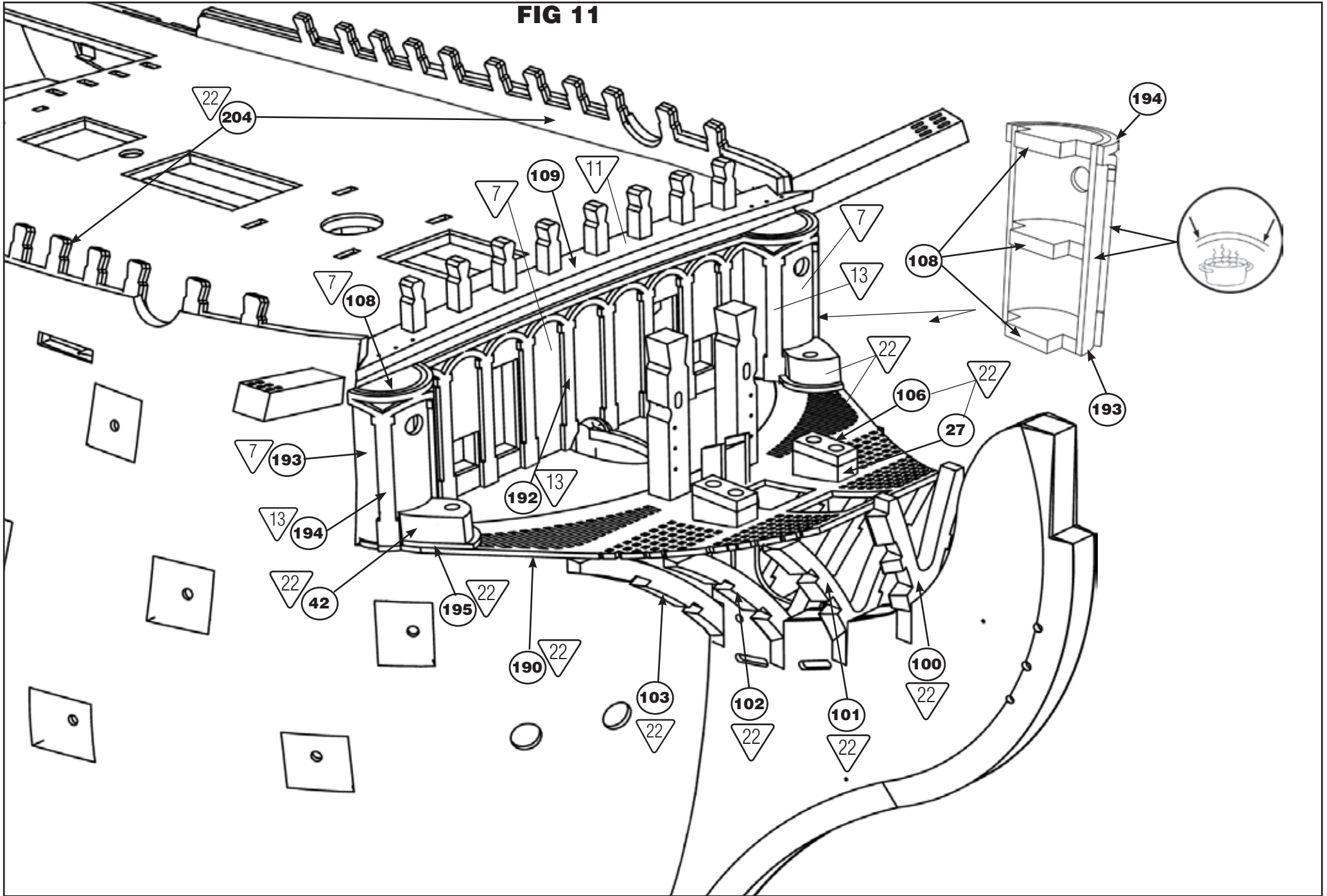


FIG 12

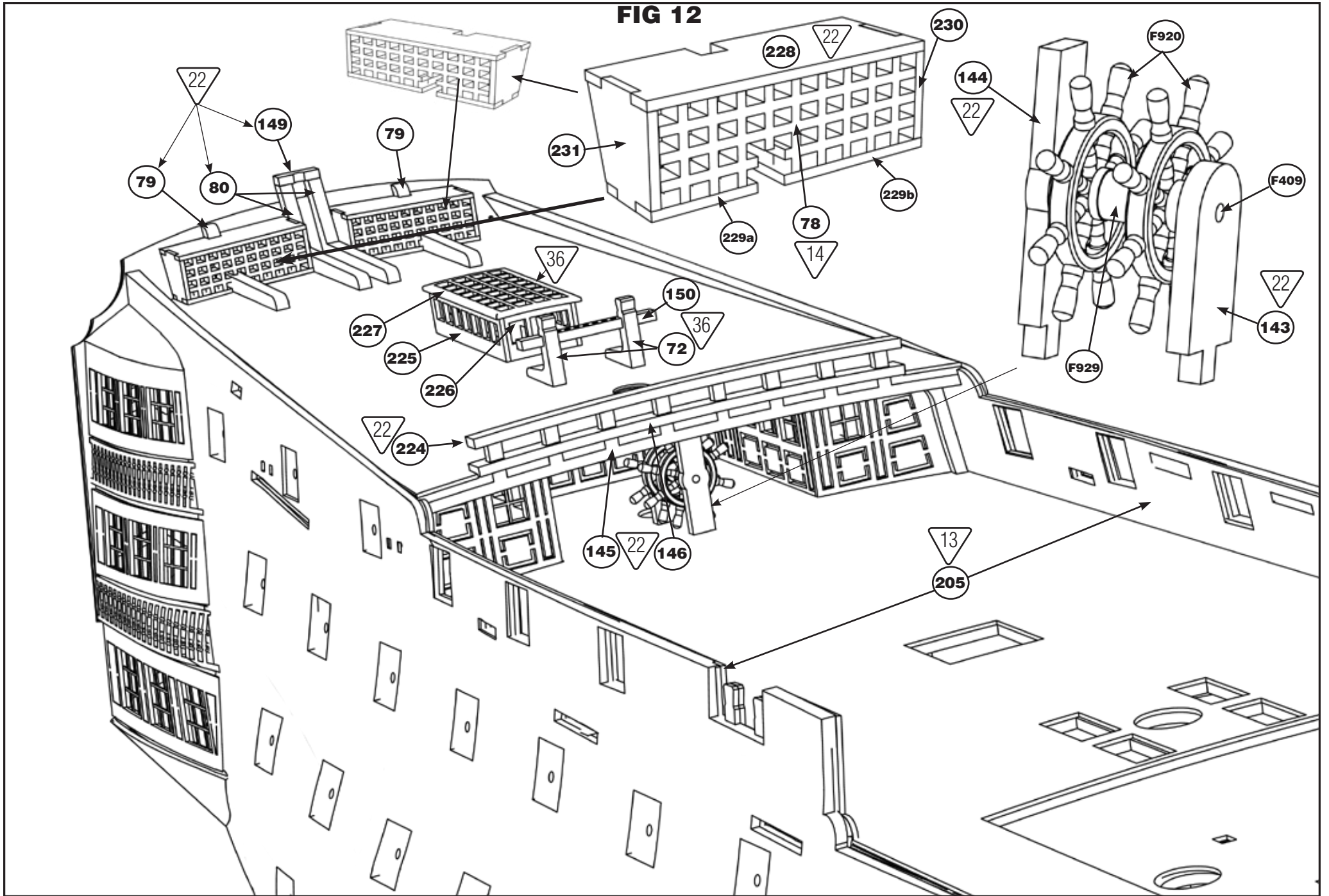


FIG 13

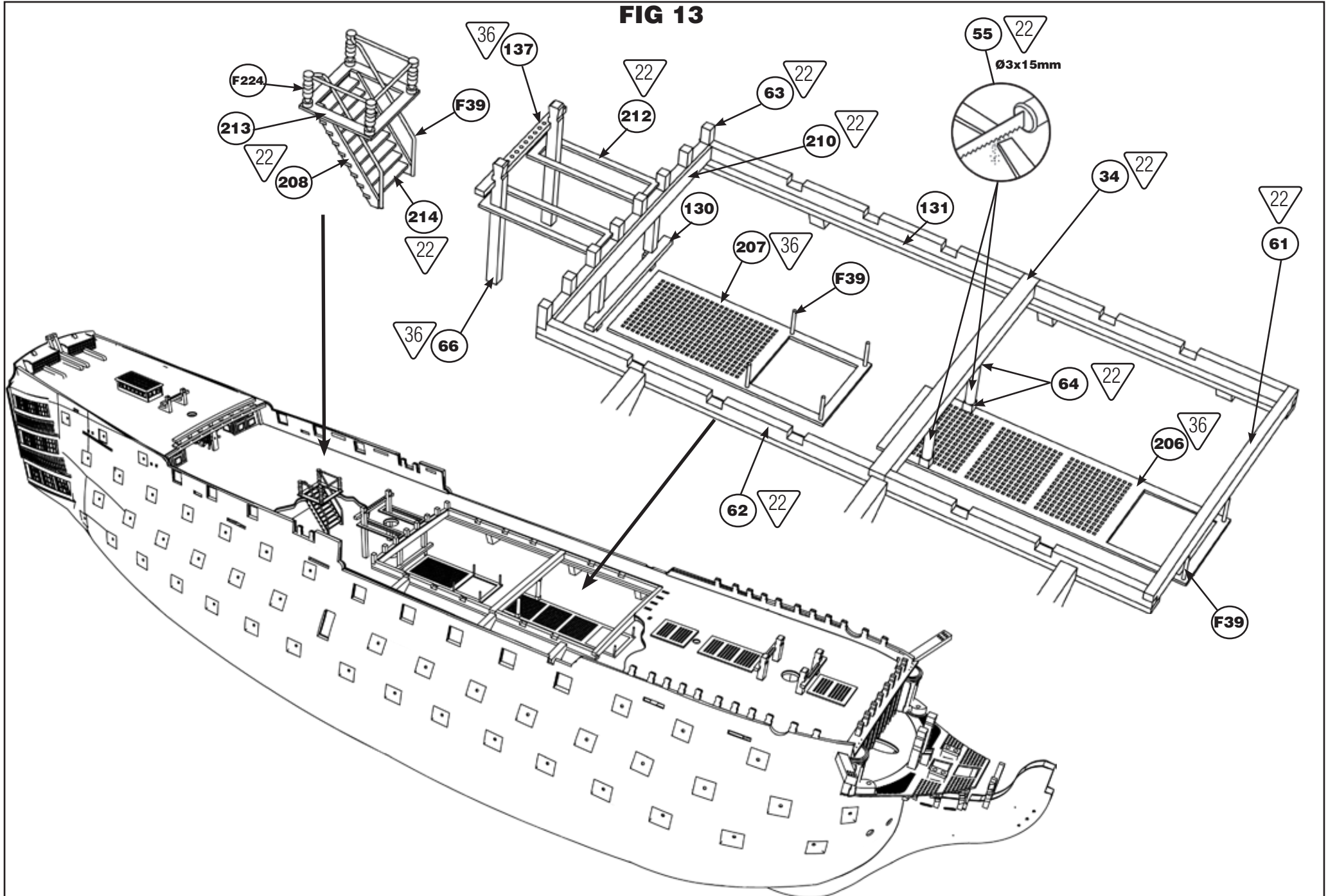


FIG 14

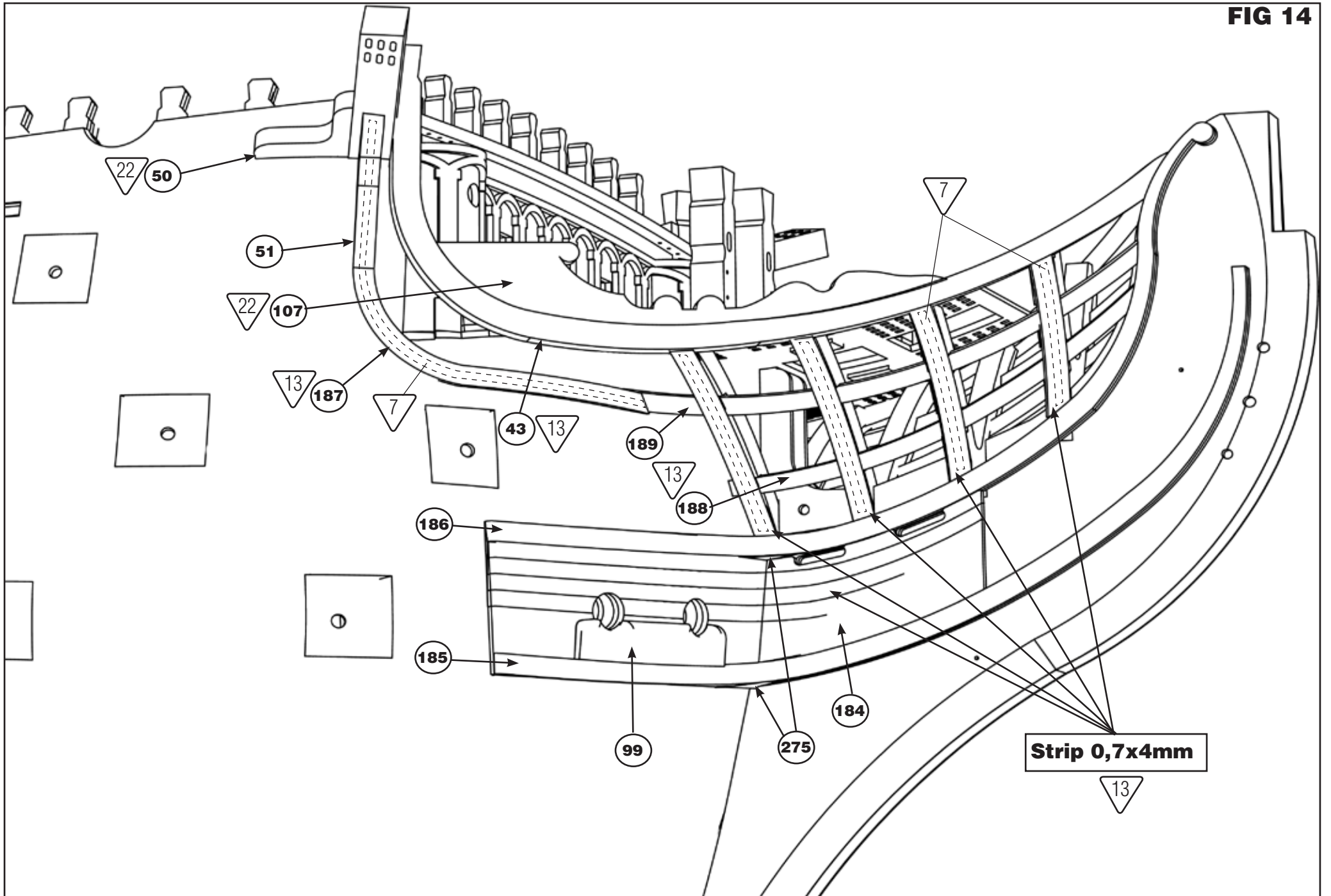


FIG 15

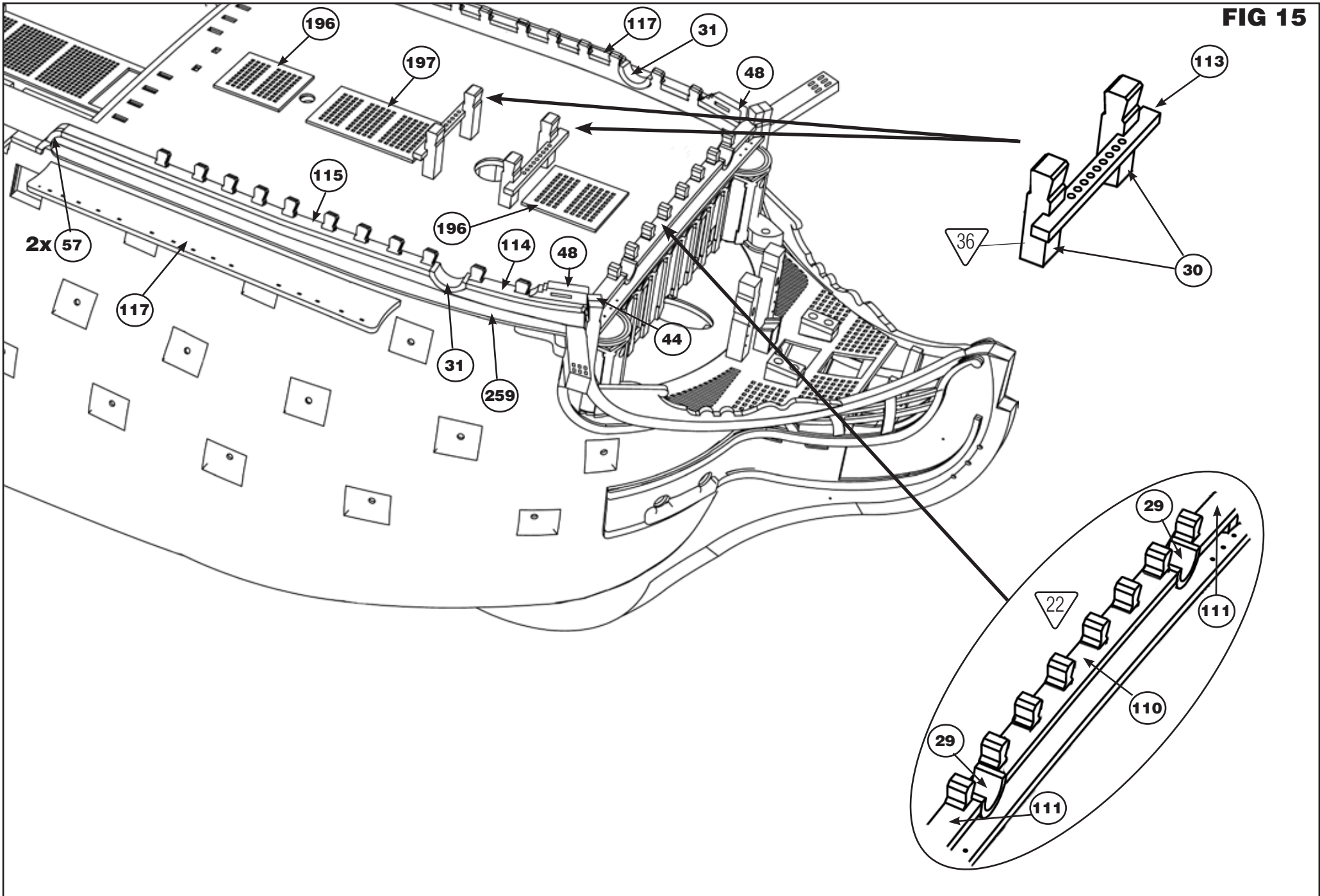


FIG 16

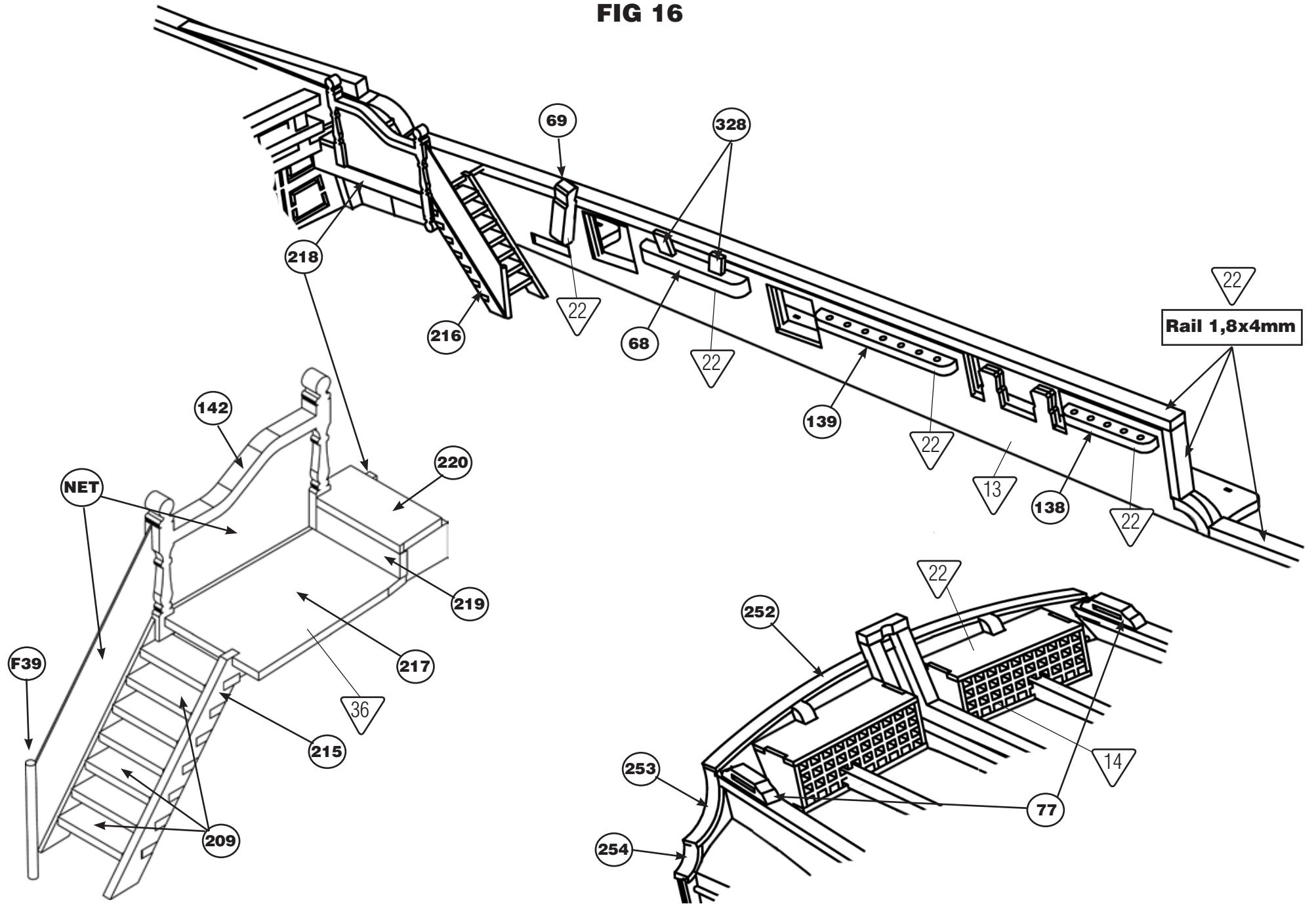


FIG 16A

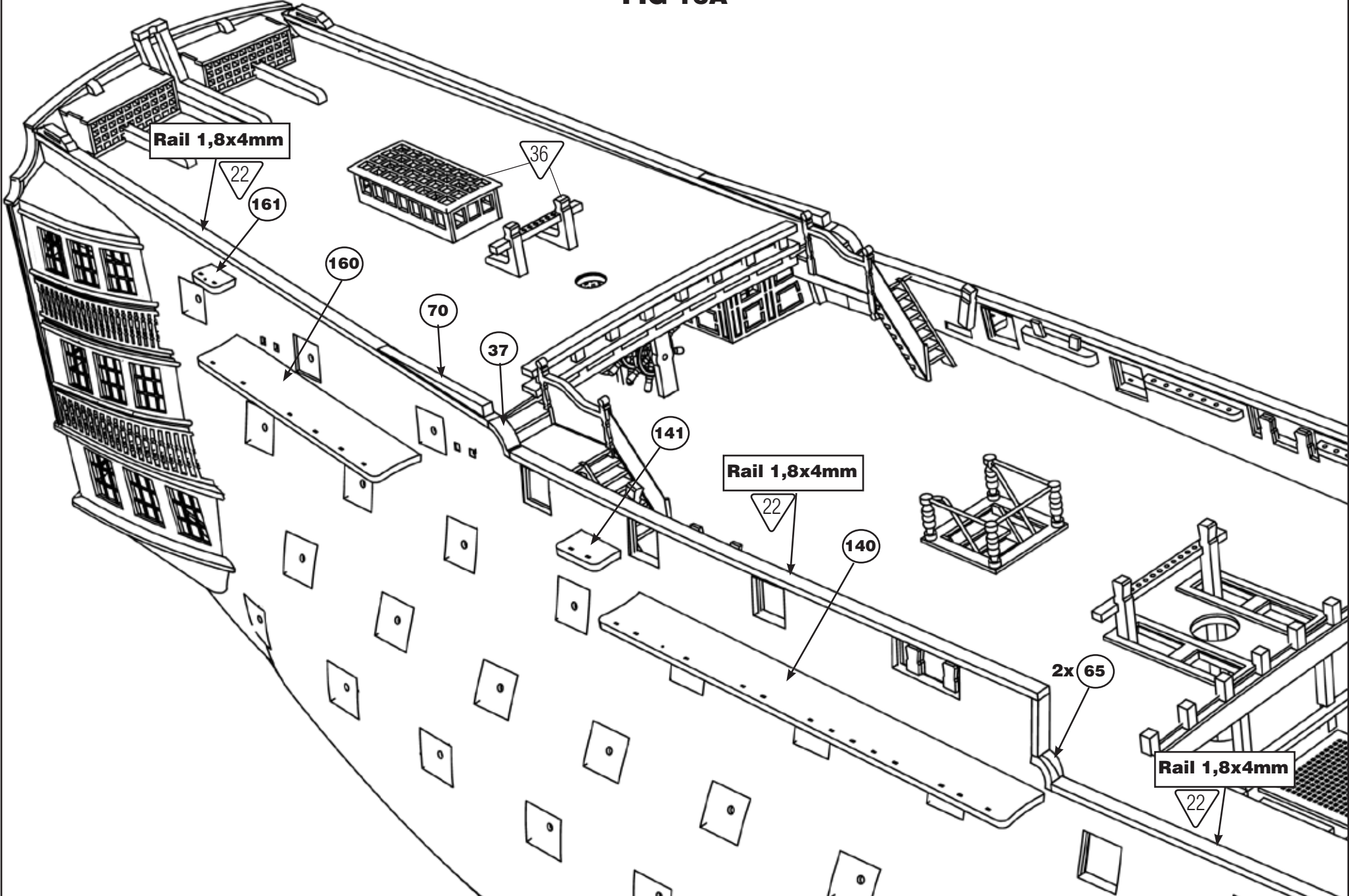


FIG 17

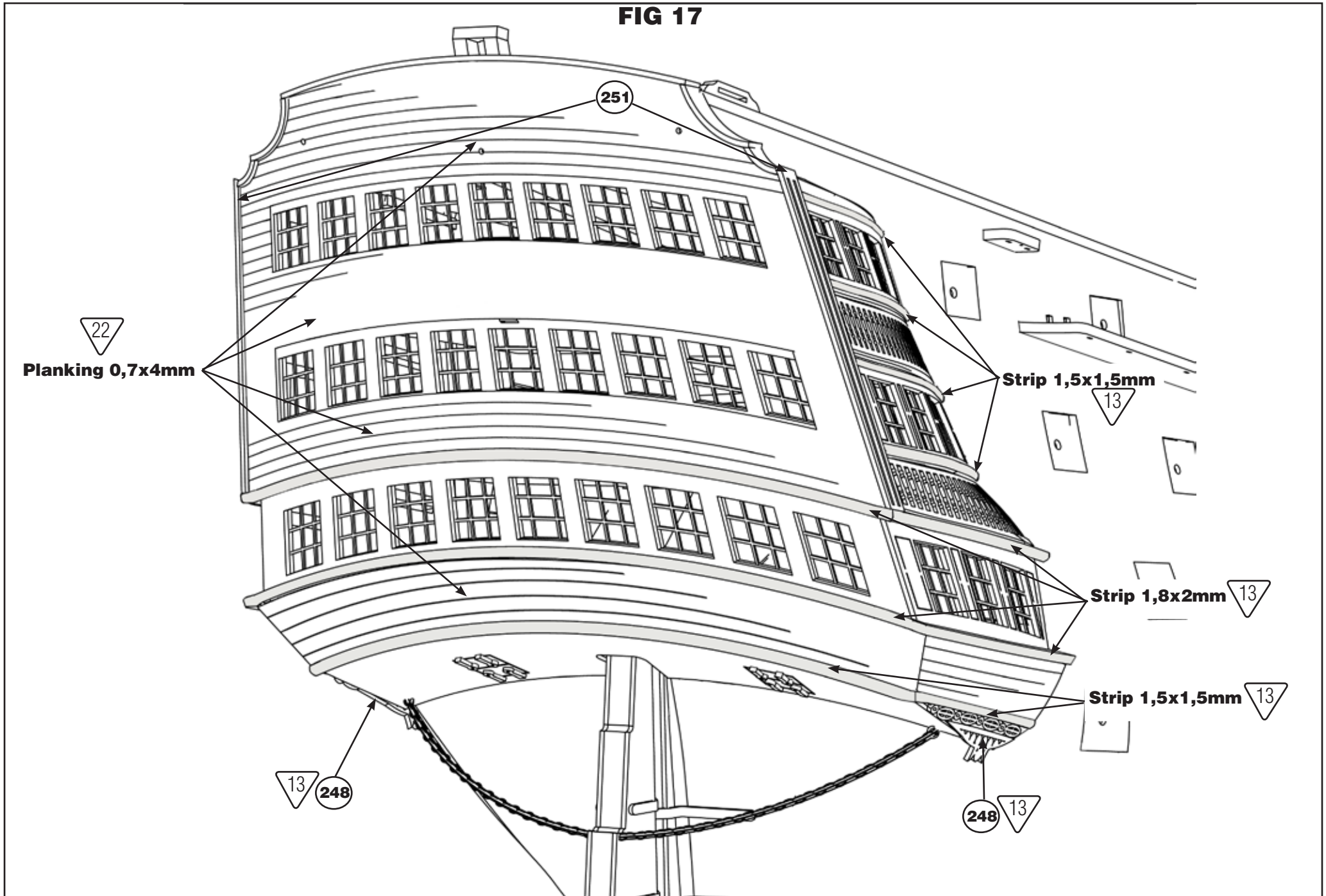


FIG 17A

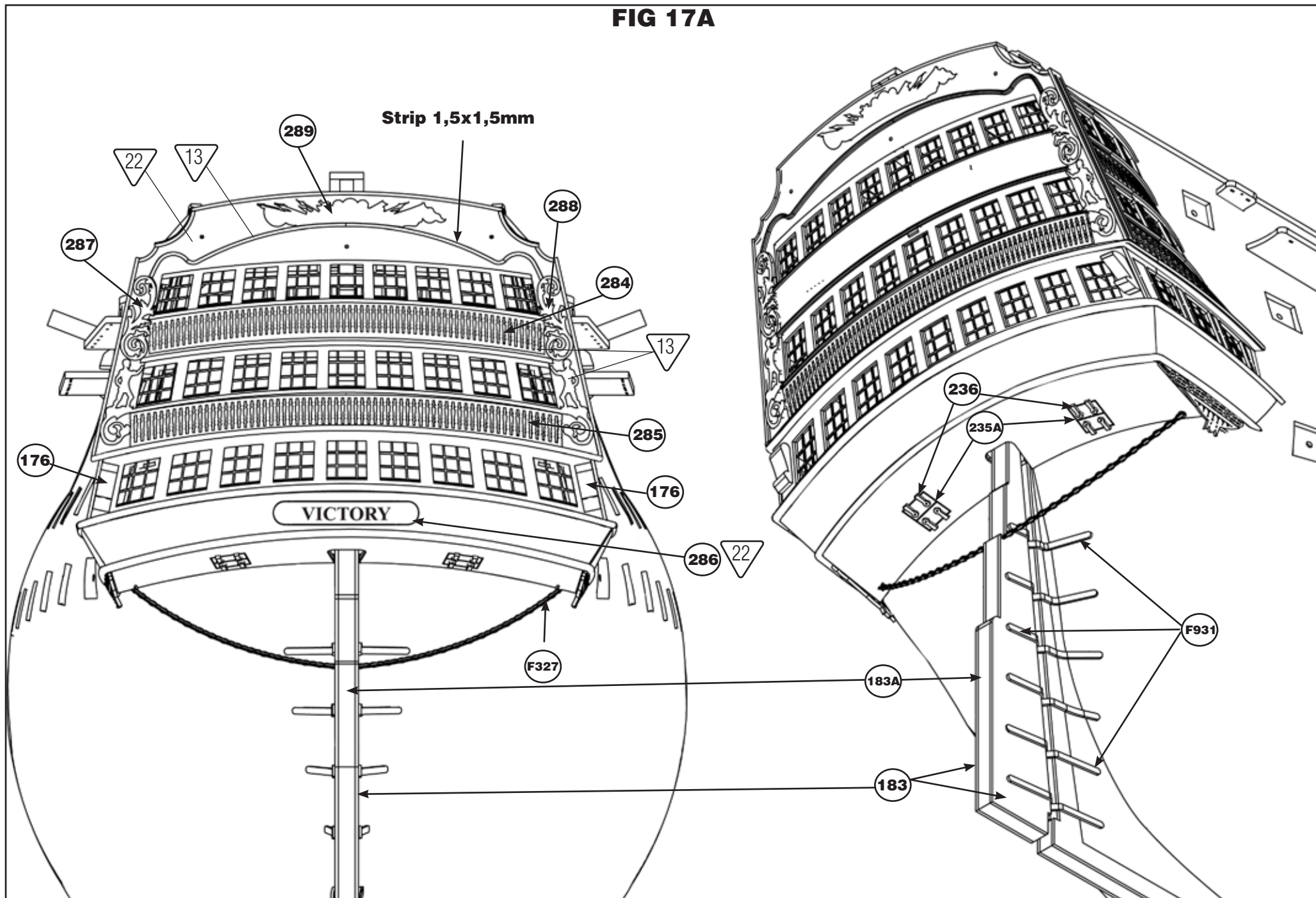


FIG 18

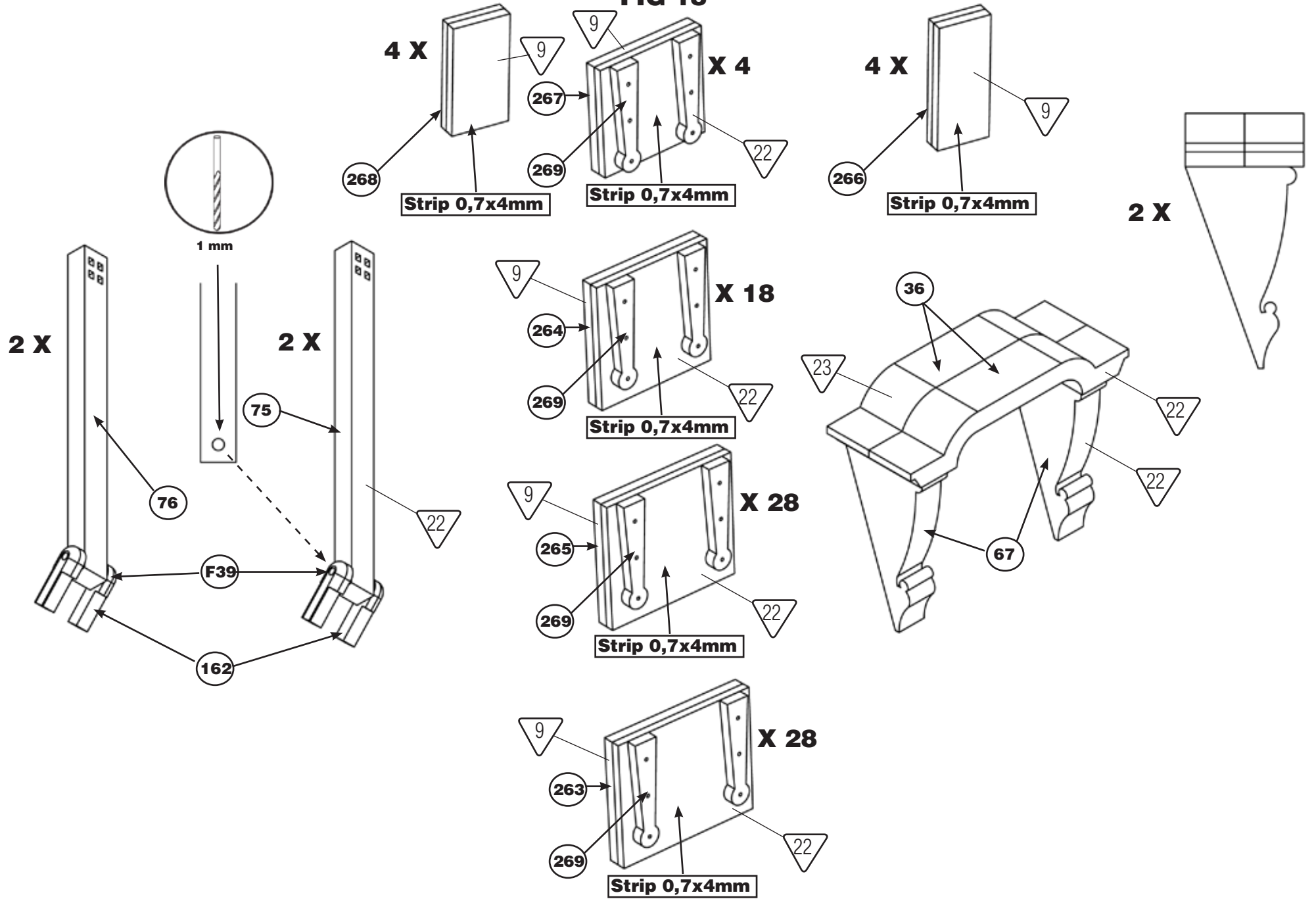


FIG 18A

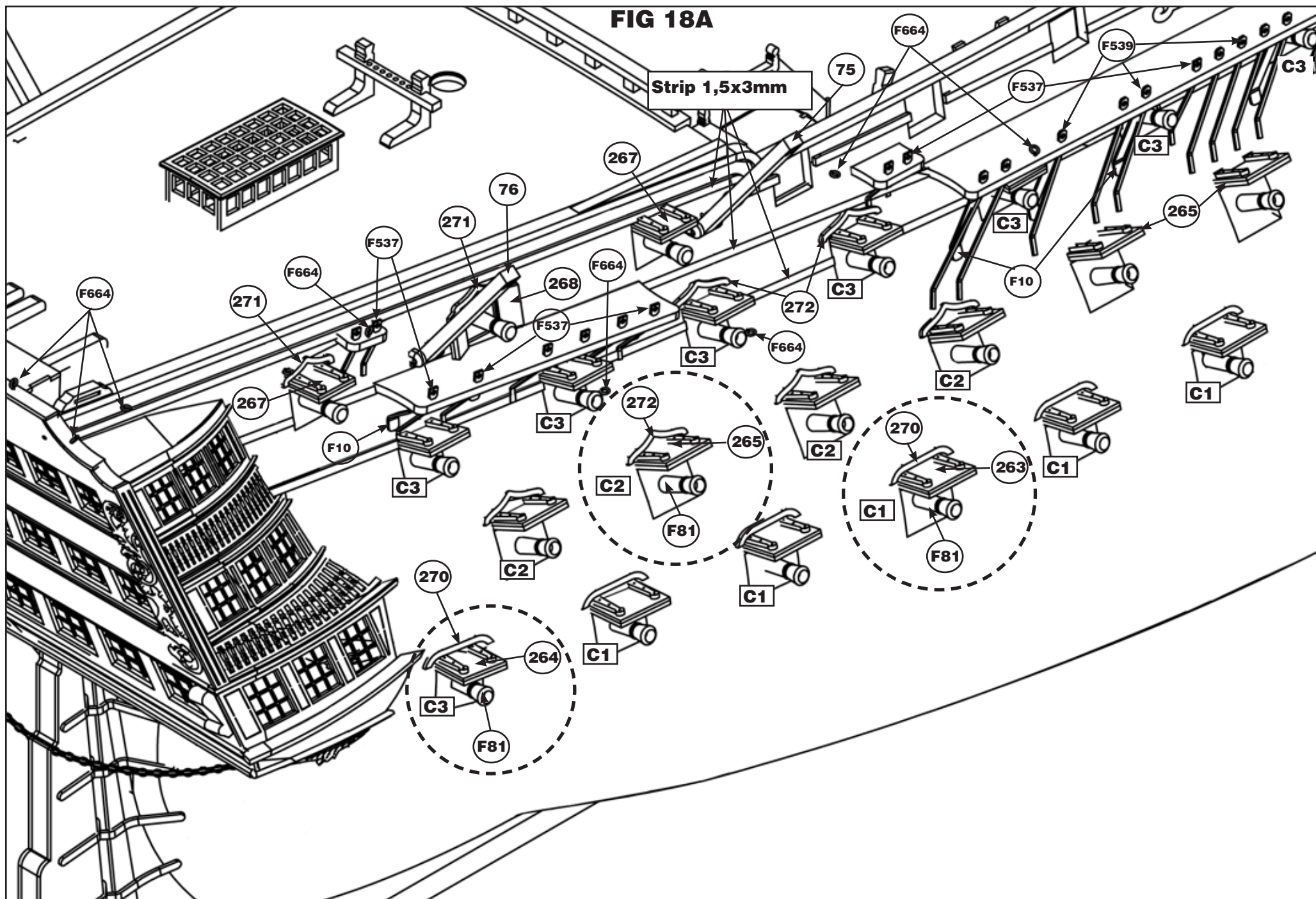


FIG 18B

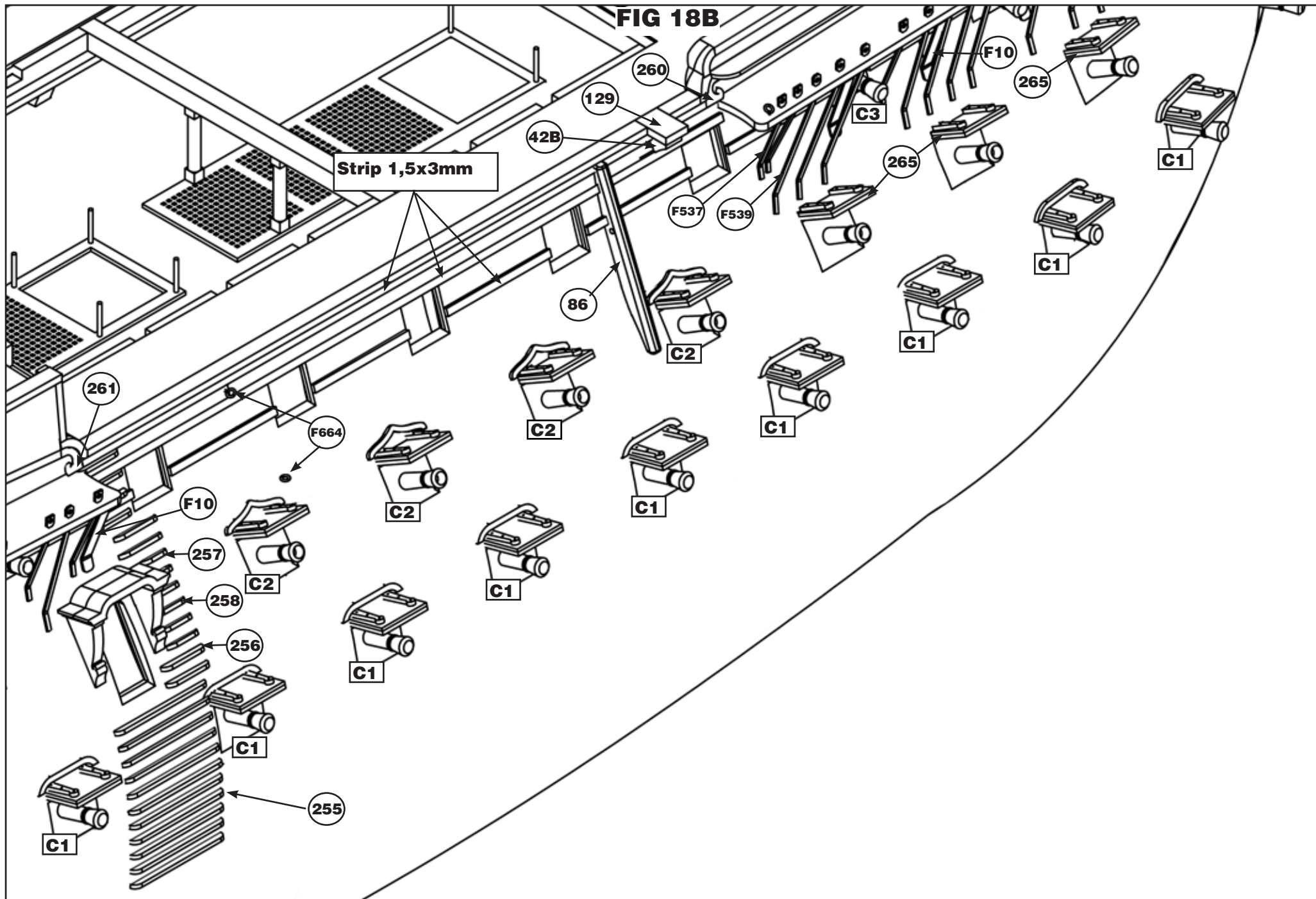


FIG 18C

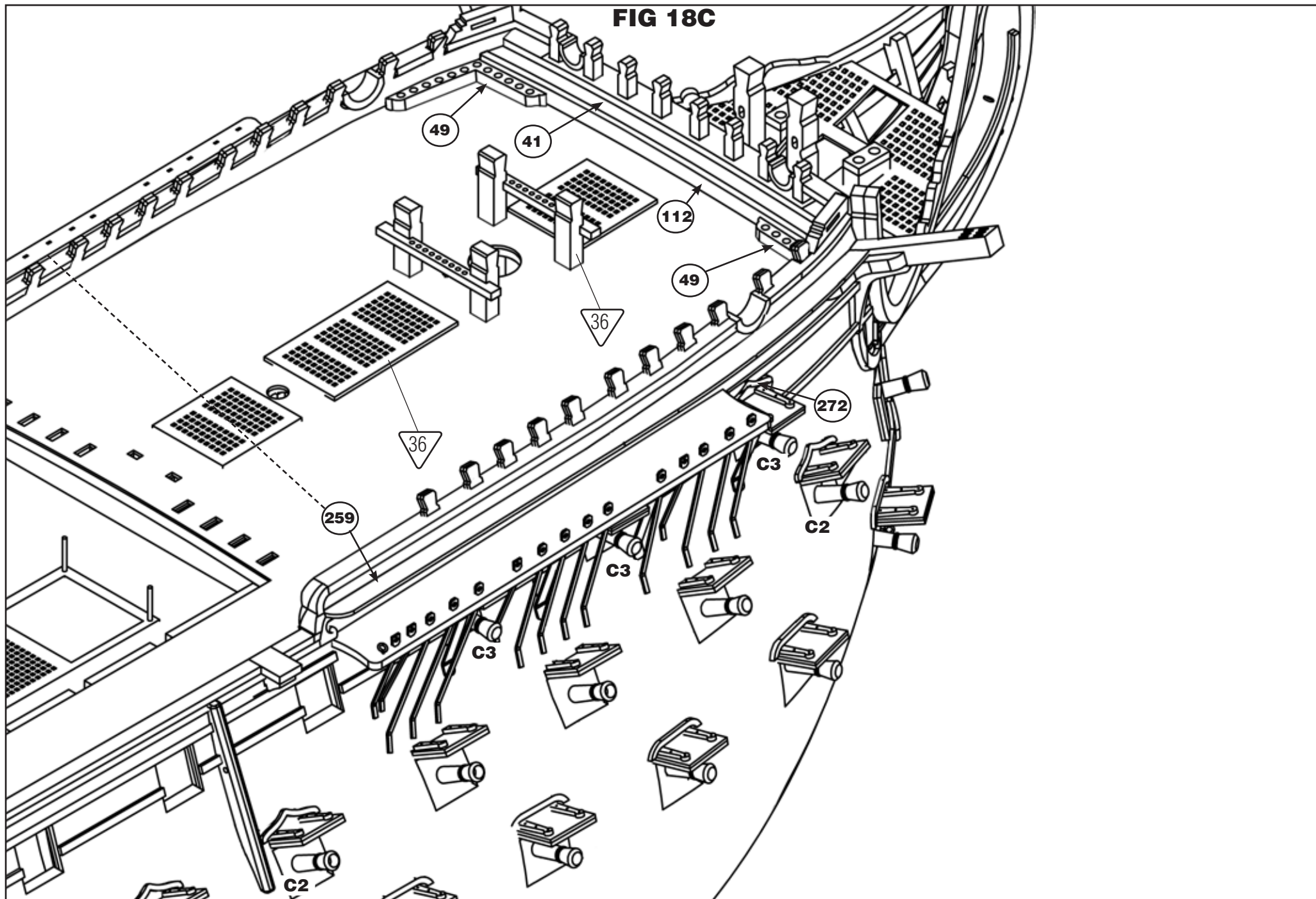


FIG 19

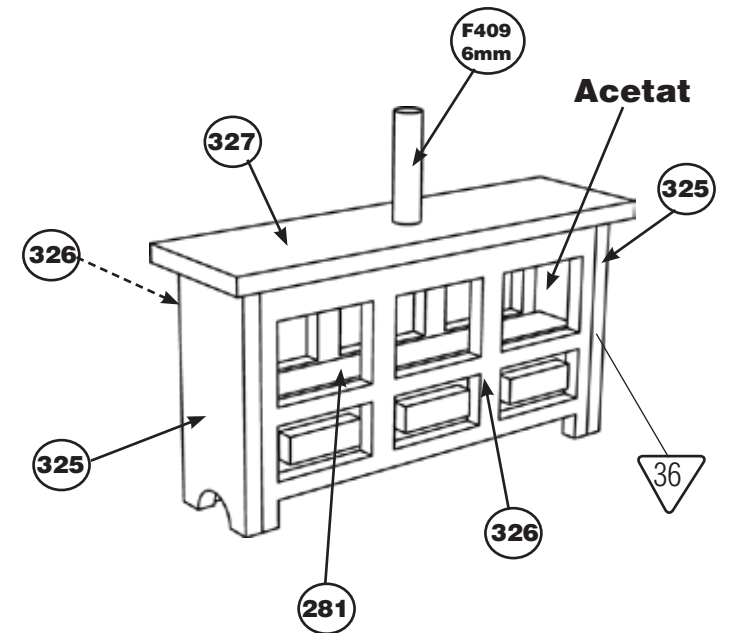
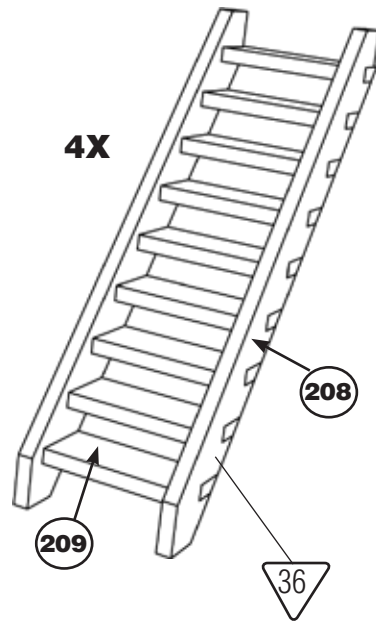
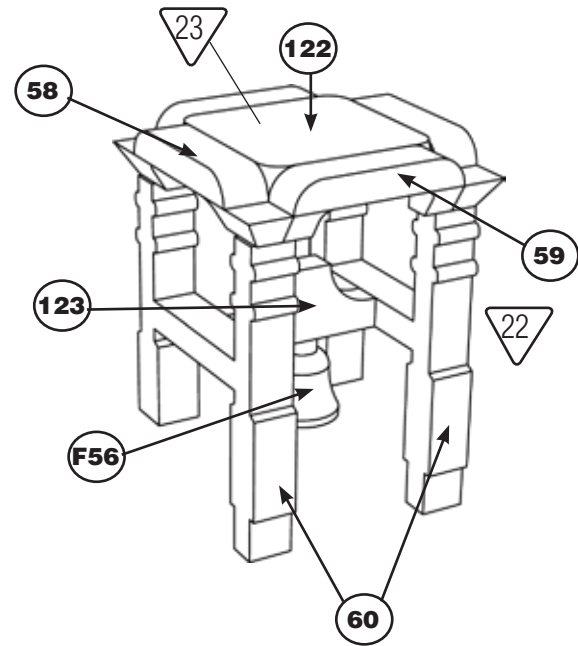
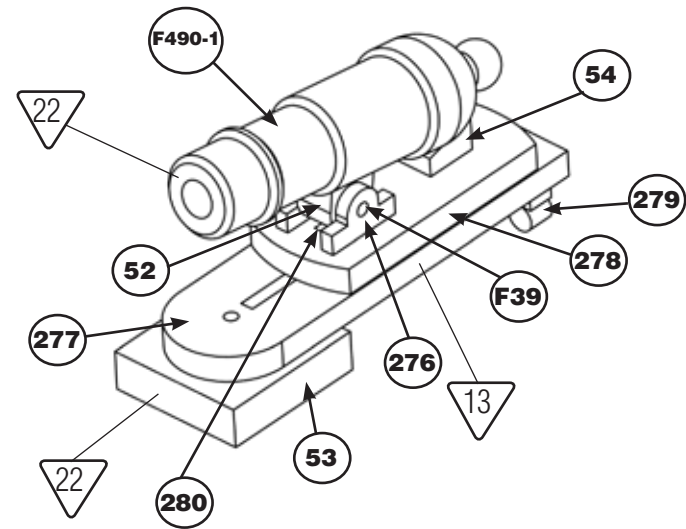
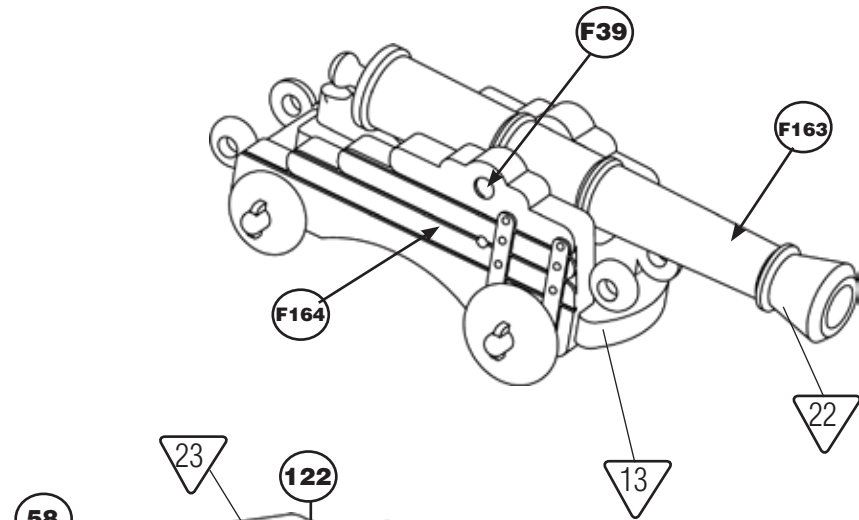


FIG 19A

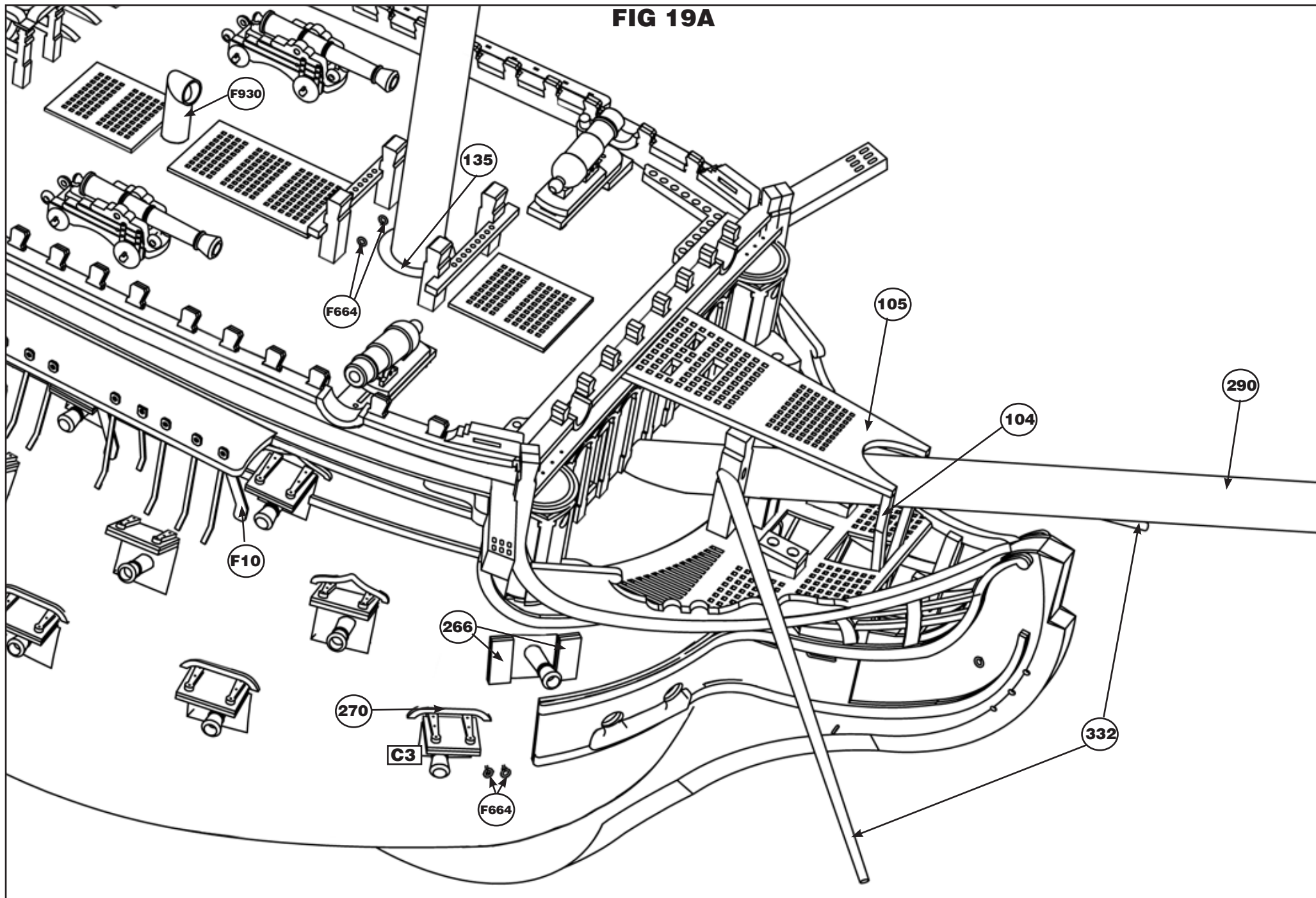


FIG 19B

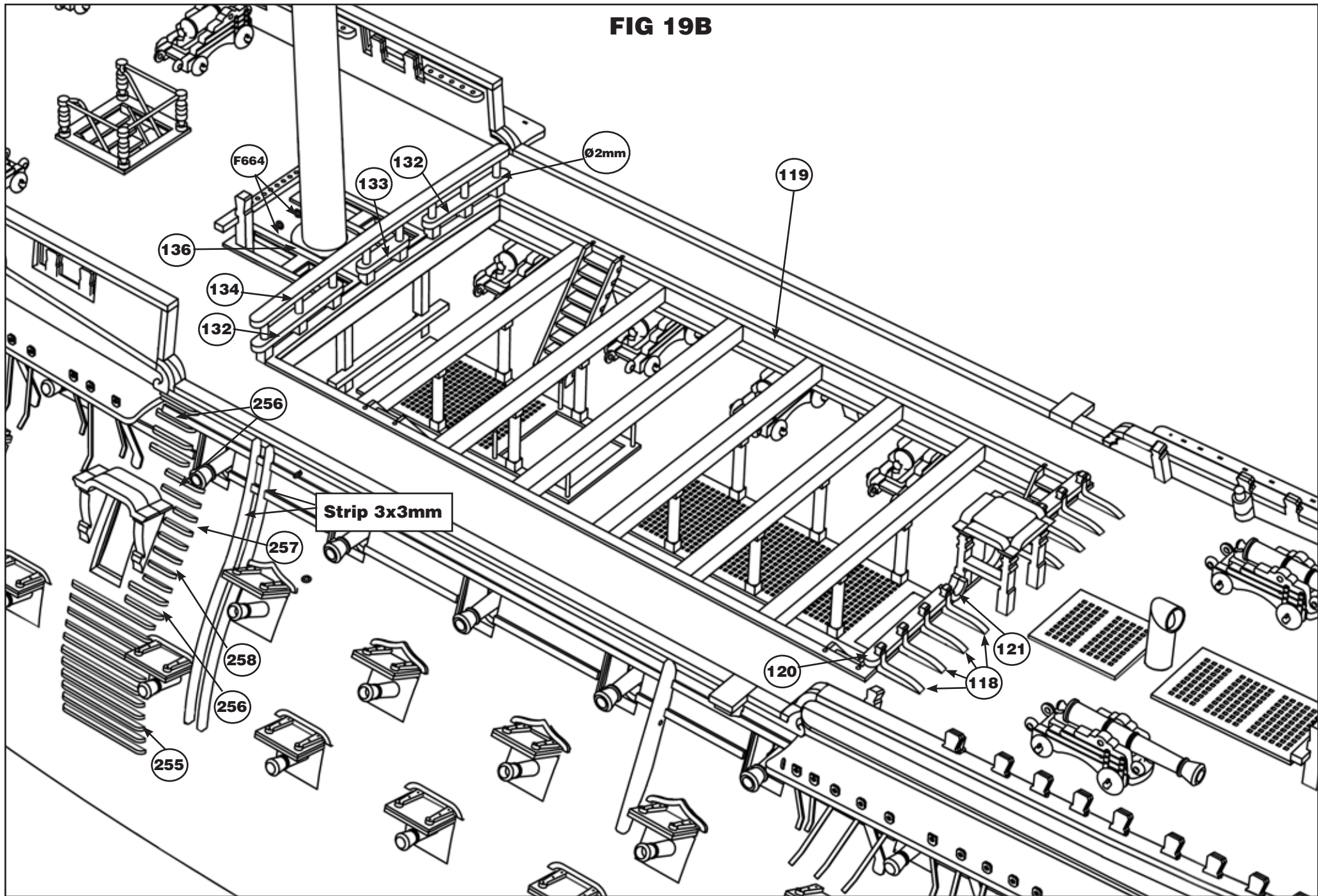


FIG 19C

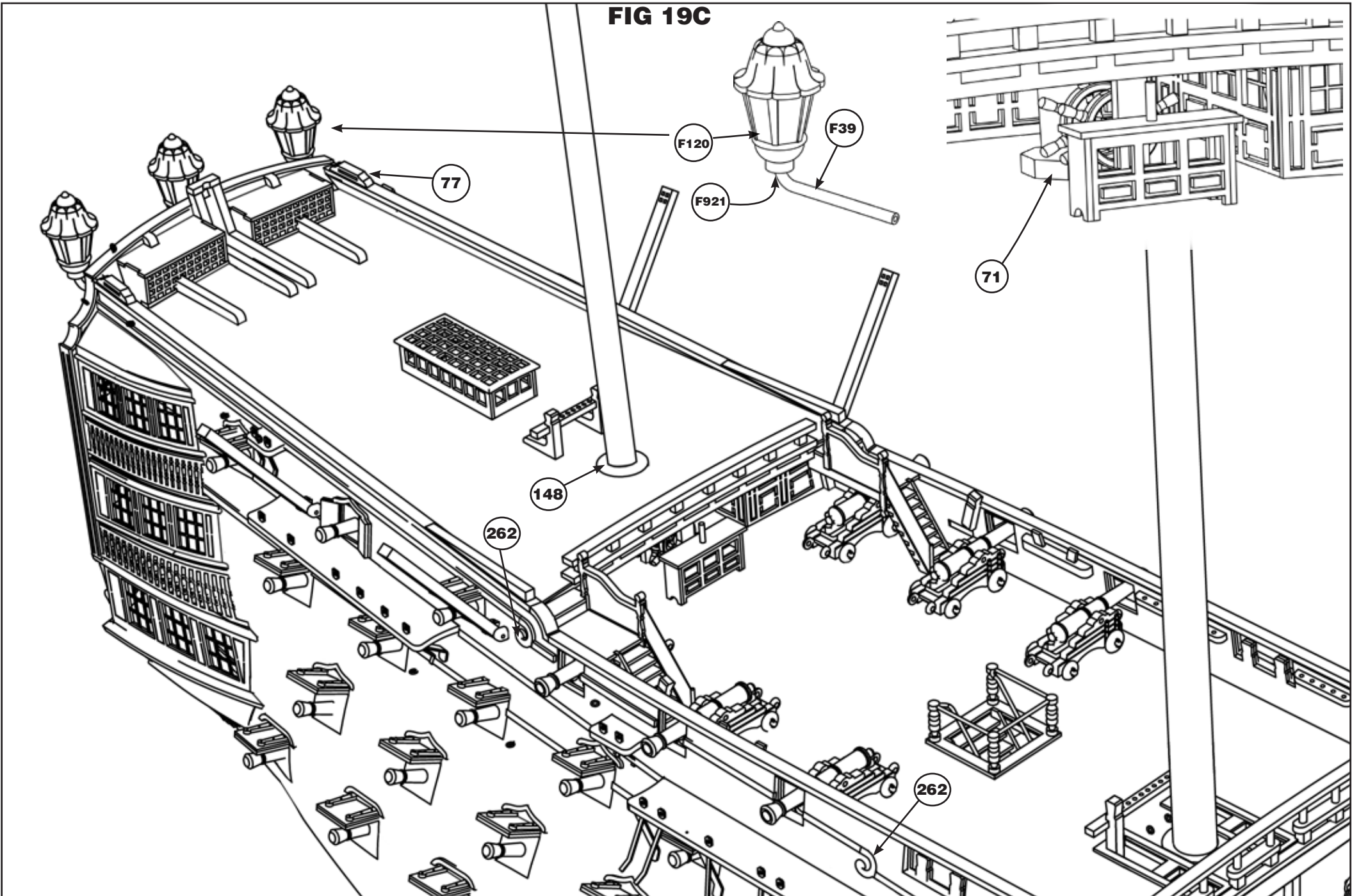


FIG 19D

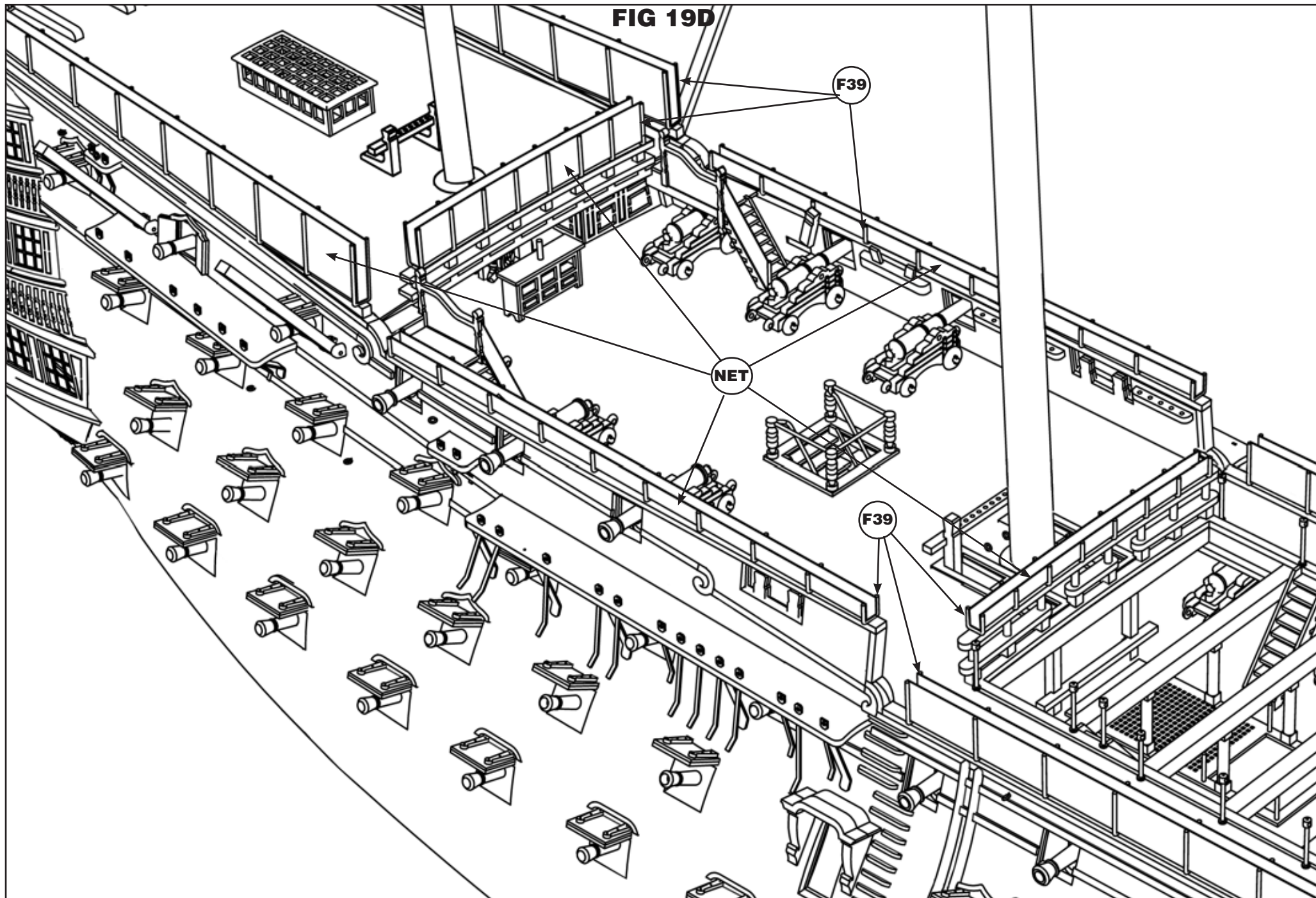


FIG 19E

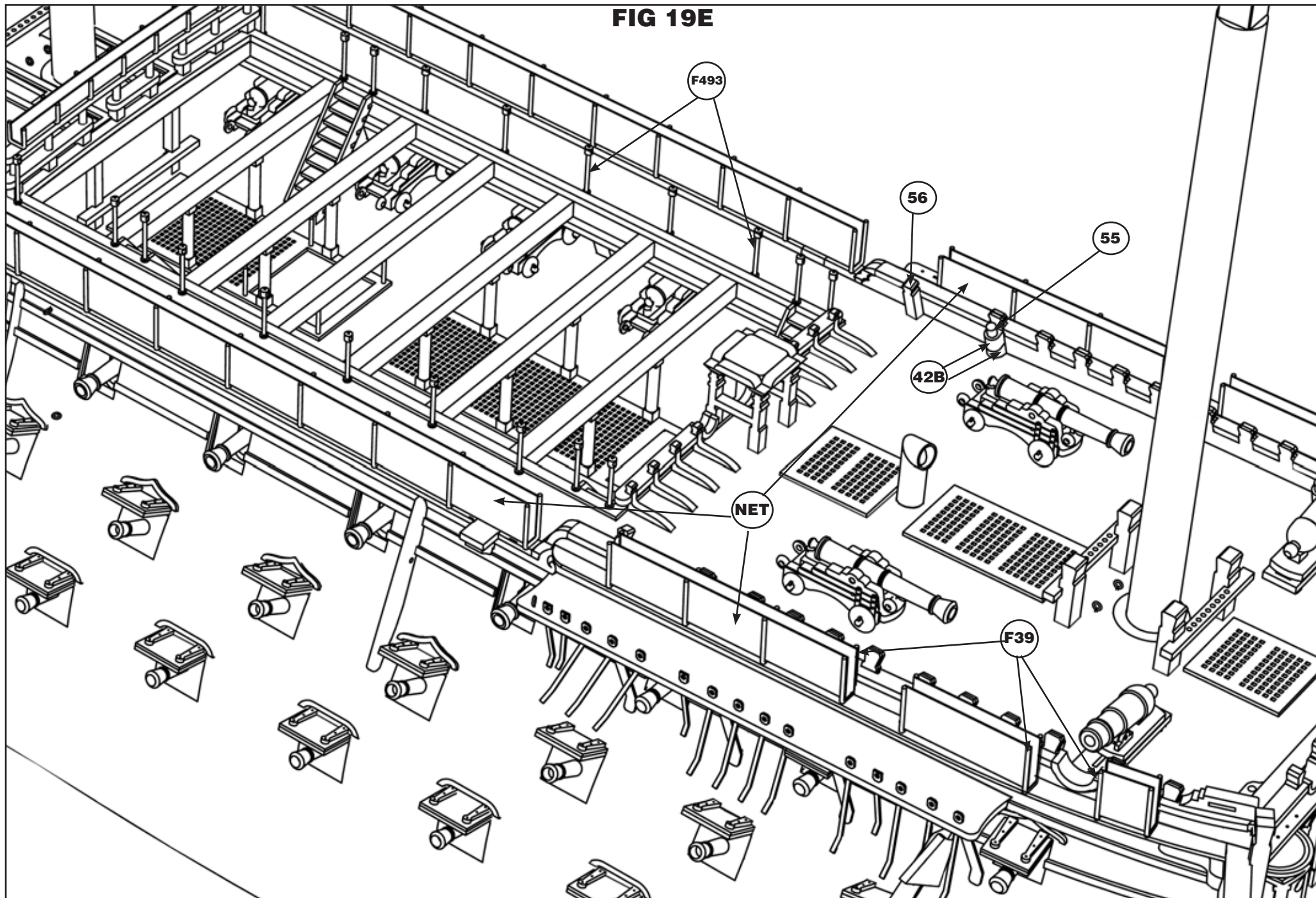
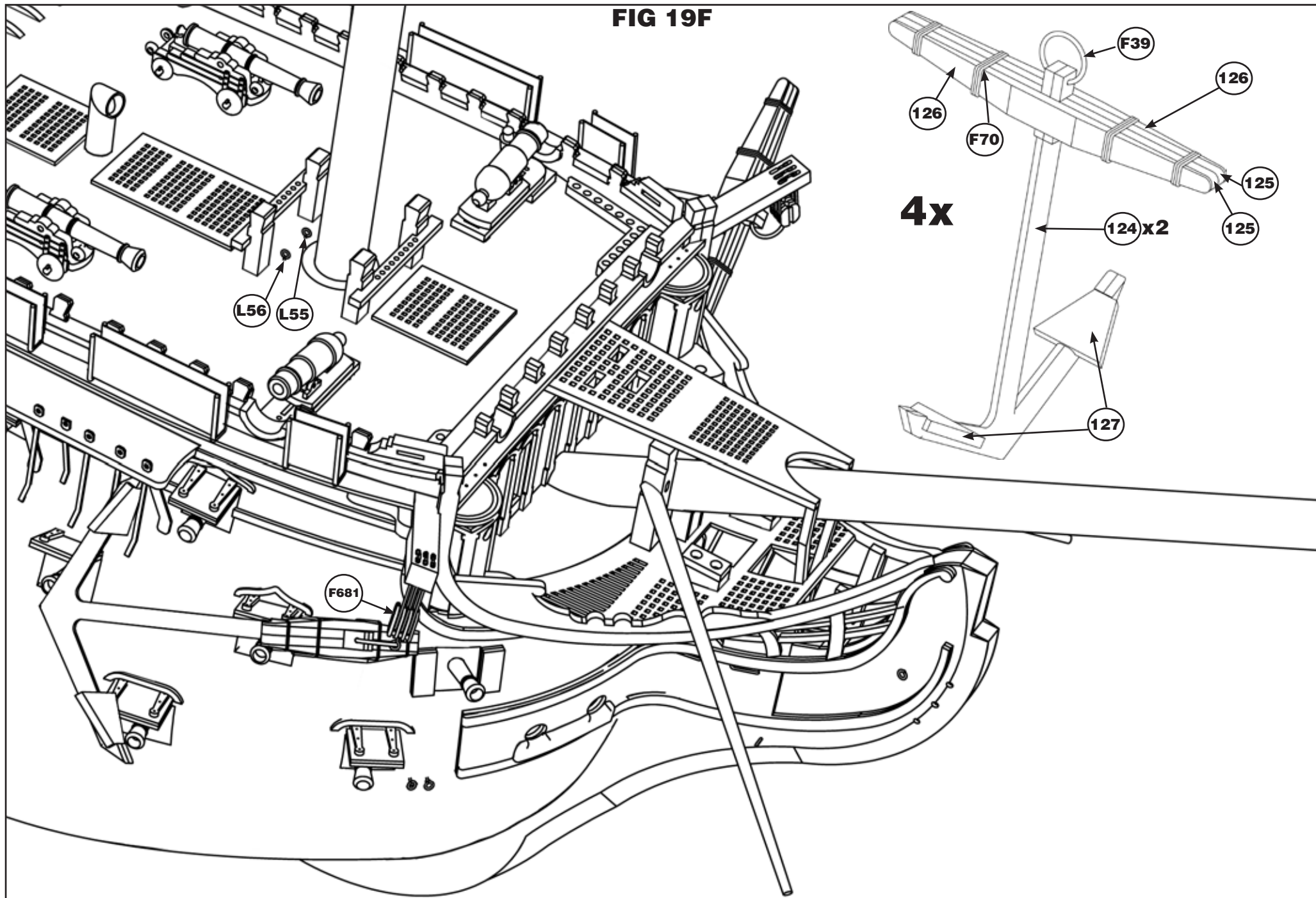


FIG 19F



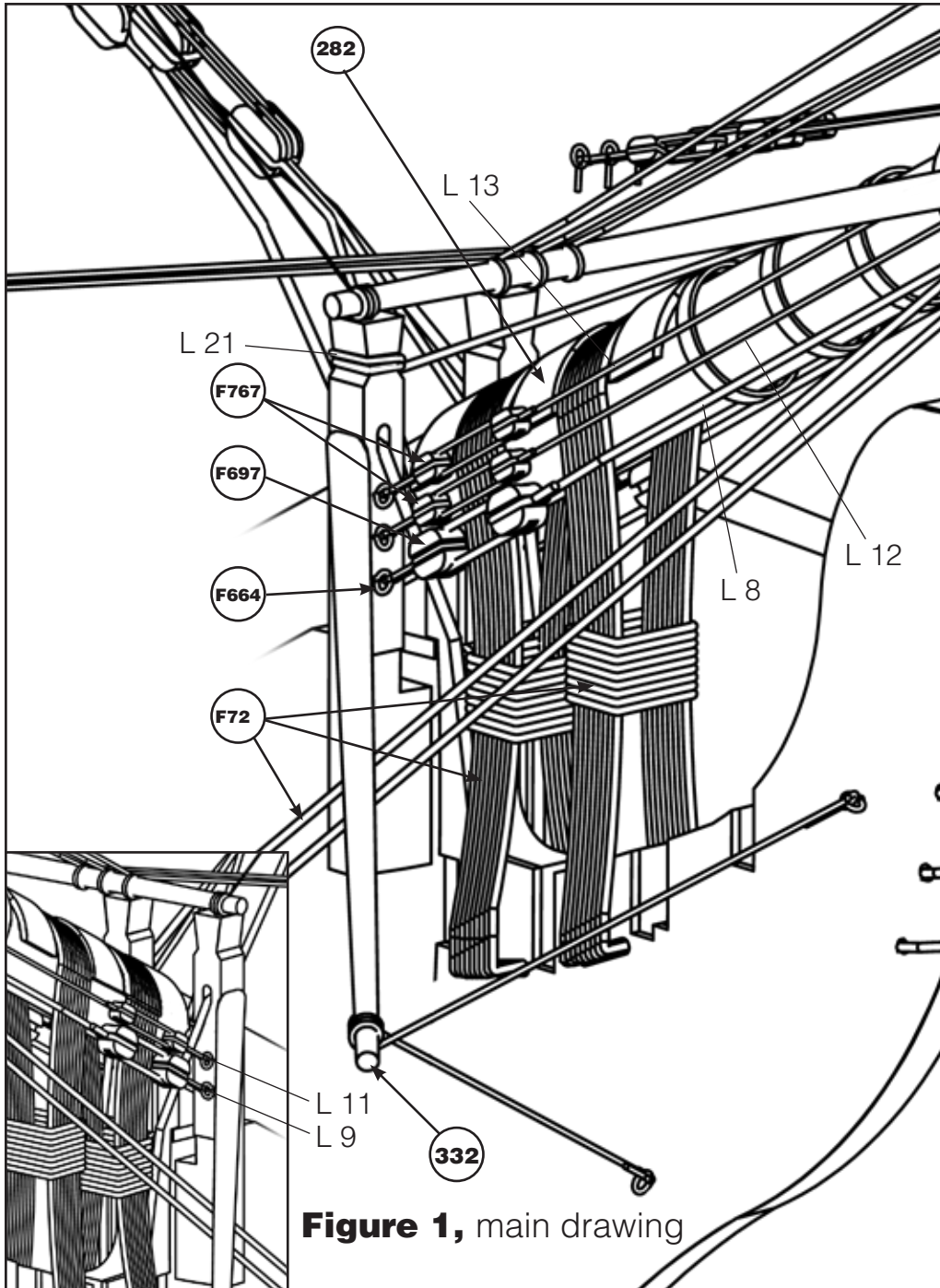


Figure 1, main drawing

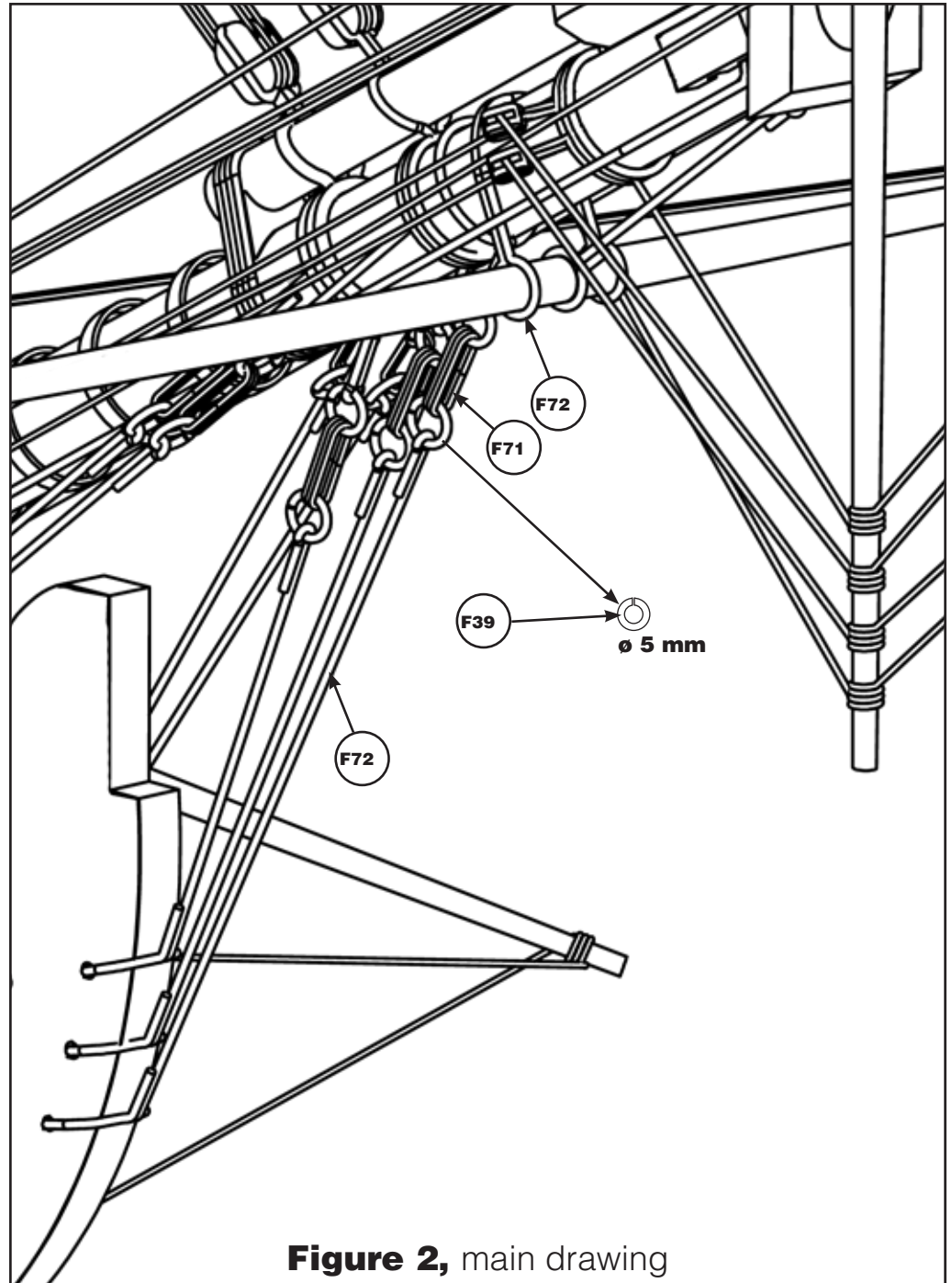
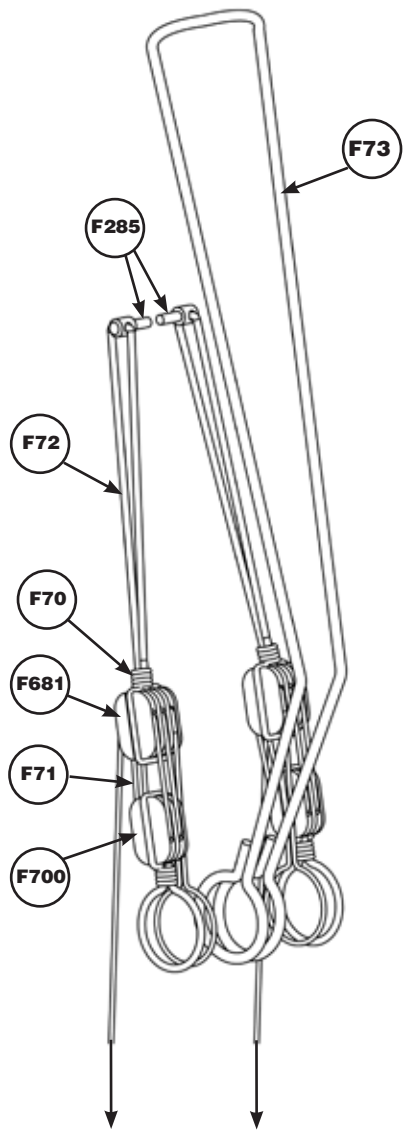


Figure 2, main drawing

Figure 3, main drawing

3 x



- L 37 Fore Mast L 38
- L 50 Main Mast L 51
- L 69 Mizzen Mast L 70

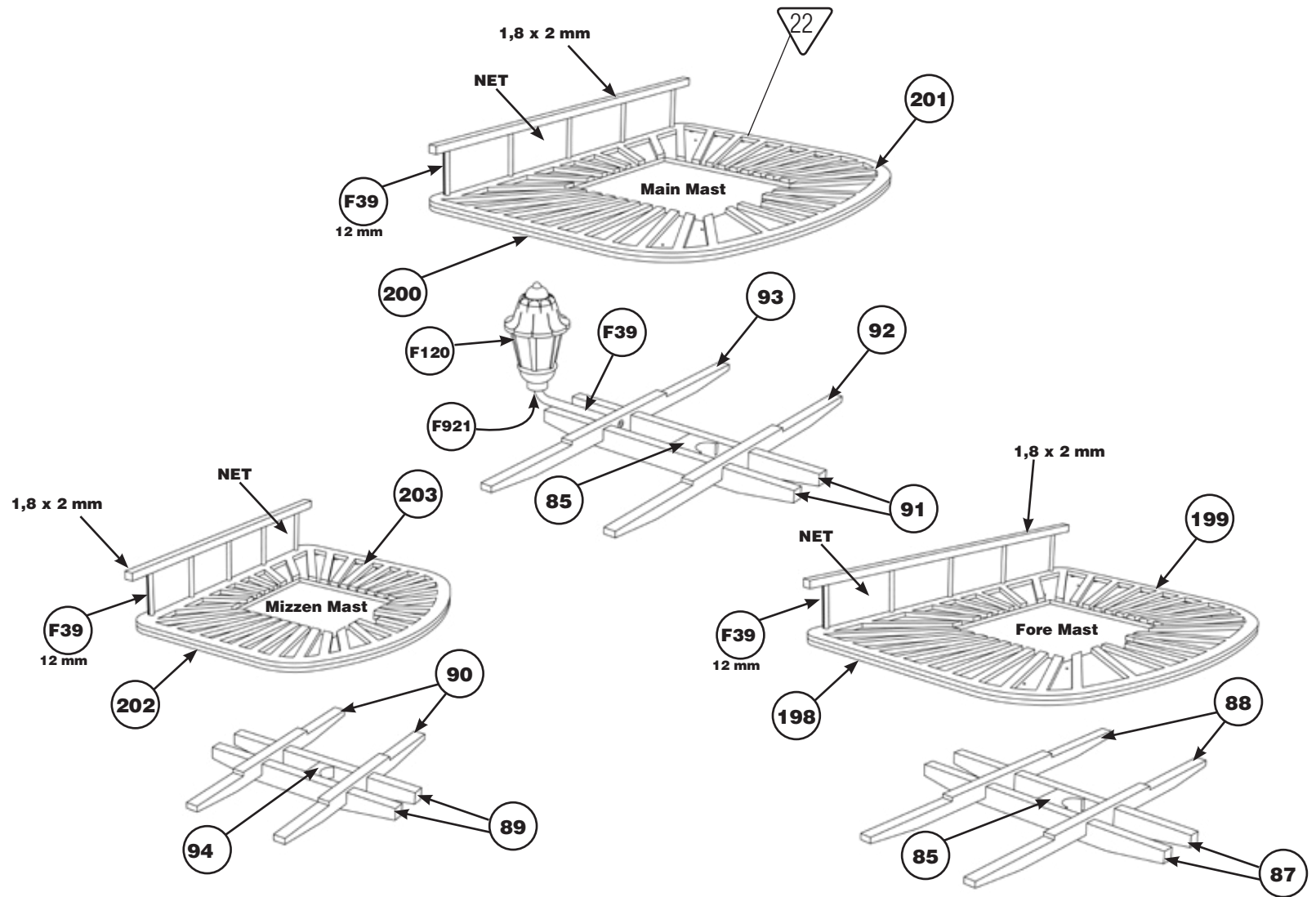


Figure 4, main drawing

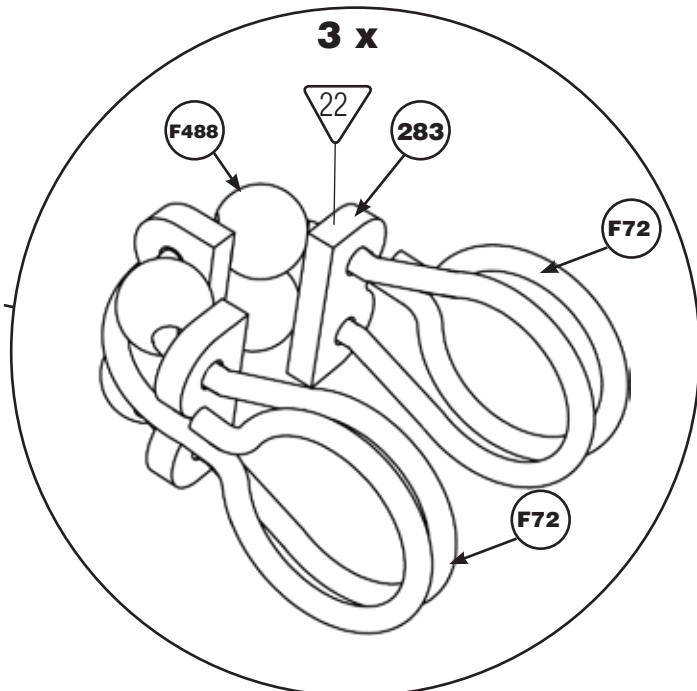
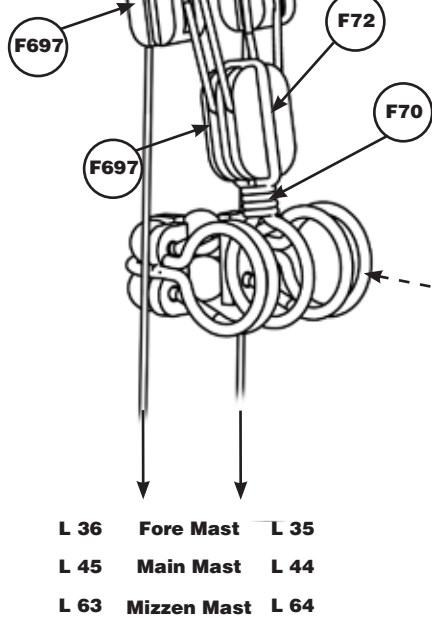
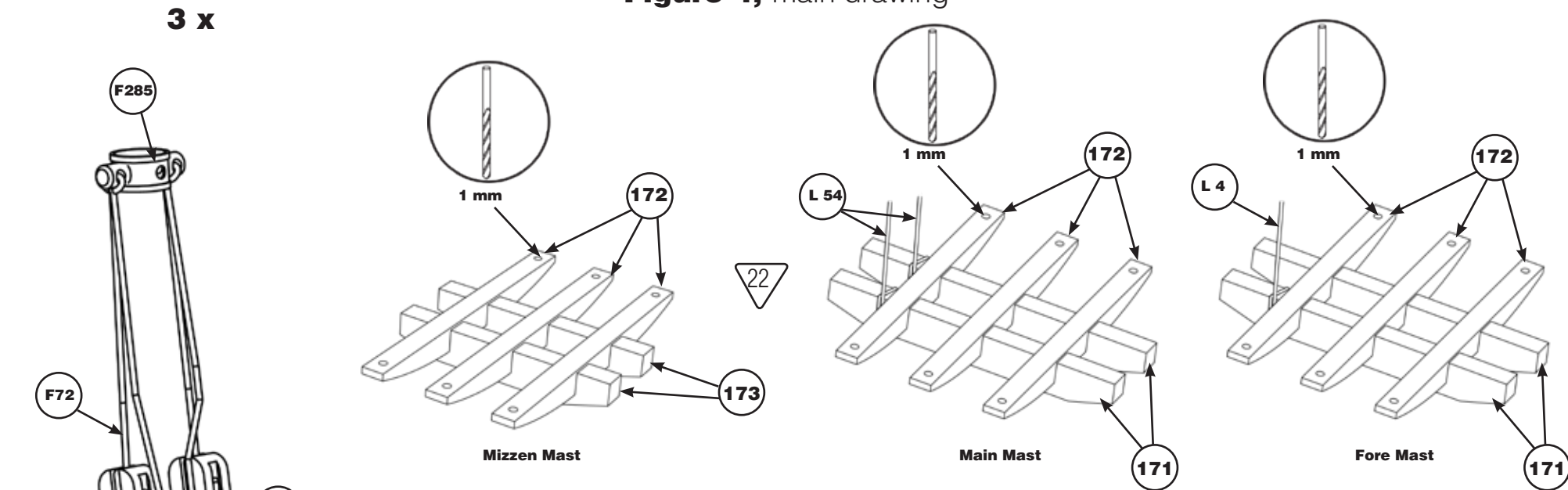
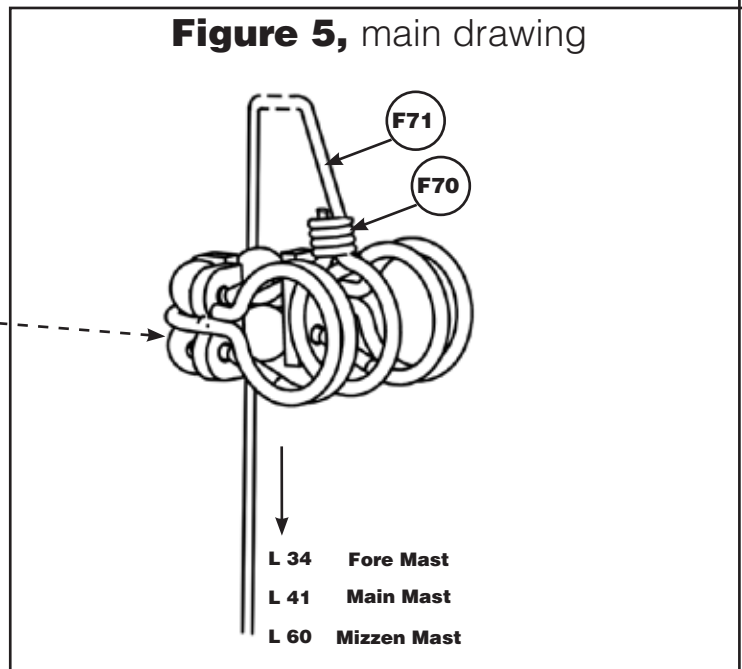










Figure 5, main drawing







Symboler  = Rigningsnummer
 = Farvenummer



Symbols  = Rigging No.
 = Colour No.



Zeichen  = Takel Nr.
 = Farben Nr.

Symboles  = Greement no.
 = Couleur no.

Symbolen  = Tuigage Nr.
 = Kleur Nr.

Símbolo  = Oparejo Nr.
 = Color Nr.

Segno  = Attrezzatura N°
 = Colore N°

Simbolos  = Cordame n°
 = Cõr n°

Til denne model er mahogni bejdse og farver med følgende numre nødvendige:

For this model is mahogany stain and colours with the following numbers should be used:

Für dieses Modell sind Mahagoni Beize und Farben mit den folgenden Nummern notwendig:

Pour ce modèle, le mordant et les couleurs avec les numéros suivants doivent être employées:

Voor dit model zijn kleuren met de volgende nummers nodig:

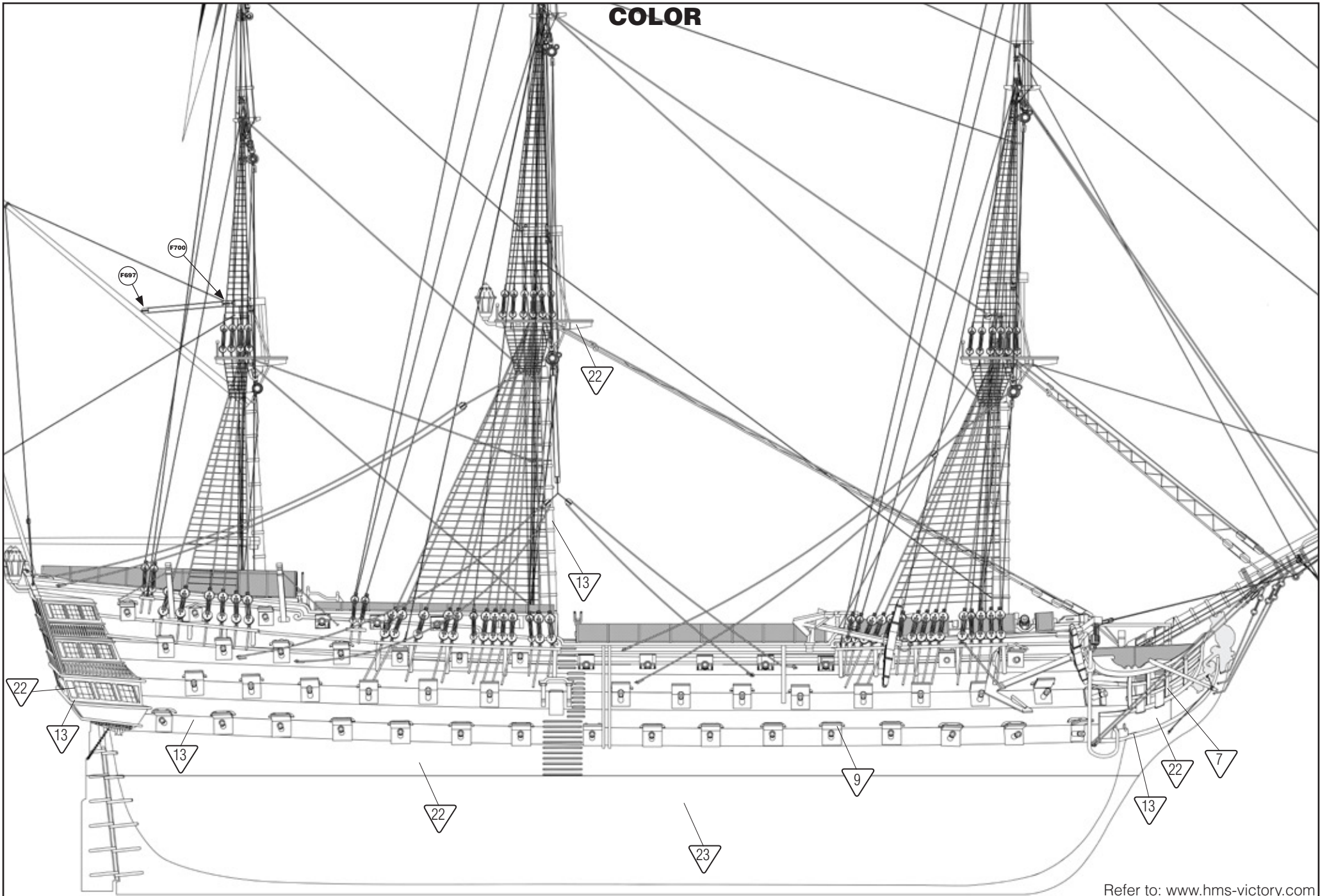
Para est modelo se necesitan mordiente et colores con los siguientes números:

Per questo modello occorrono inchiostro tinteggiatore "mogano" e colori con questi numeri:

Pinte o modelo com tintura cõr Mogno e as cõres sugeridas da Billing Boats:

Billing	7	=	Sea Blue
Billing	9	=	Bright Red
Billing	13	=	Trainer Yellow
Billing	14	=	Matt White
Billing	22	=	Flat Black
Billing	23	=	Copper
Billing	36	=	Mahogany Stain

COLOR



Refer to: www.hms-victory.com

