

 BLADE®

Fusion 480



Instruction Manual
Bedienungsanleitung
Manuel d'utilisation
Manuale di Istruzioni

NOTICE

All instructions, warranties and other collateral documents are subject to change at the sole discretion of Horizon Hobby, LLC. For up-to-date product literature, visit horizonhobby.com and click on the support tab for this product.

Meaning of Special Language

The following terms are used throughout the product literature to indicate various levels of potential harm when operating this product:

WARNING: Procedures, which if not properly followed, create the probability of property damage, collateral damage, and serious injury OR create a high probability of superficial injury.

CAUTION: Procedures, which if not properly followed, create the probability of physical property damage AND a possibility of serious injury.

NOTICE: Procedures, which if not properly followed, create a possibility of physical property damage AND a little or no possibility of injury.



WARNING: Read the ENTIRE instruction manual to become familiar with the features of the product before operating. Failure to operate the product correctly can result in damage to the product, personal property and cause serious injury.

This is a sophisticated hobby product. It must be operated with caution and common sense and requires some basic mechanical ability. Failure to operate this Product in a safe and responsible manner could result in injury or damage to the product or other property. This product is not intended for use by children without direct adult supervision. Do not use with incompatible components or alter this product in any way outside of the instructions provided by Horizon Hobby, LLC. This manual contains instructions for safety, operation and maintenance. It is essential to read and follow all the instructions and warnings in the manual, prior to assembly, setup or use, in order to operate correctly and avoid damage or serious injury.

Age Recommendation: Not for children under 14 years. This is not a toy.

Safety Precautions and Warnings

- Always keep a safe distance in all directions around your model to avoid collisions or injury. This model is controlled by a radio signal subject to interference from many sources outside your control. Interference can cause momentary loss of control.
- Always operate your model in open spaces away from full-size vehicles, traffic and people.
- Always carefully follow the directions and warnings for this and any optional support equipment (chargers, rechargeable battery packs, etc.).
- Always keep all chemicals, small parts and anything electrical out of the reach of children.
- Always avoid water exposure to all equipment not specifically designed and protected for this purpose. Moisture causes damage to electronics.
- Never place any portion of the model in your mouth as it could cause serious injury or even death.
- Never operate your model with low transmitter batteries.
- Always keep aircraft in sight and under control.
- Always activate throttle hold at rotor strike.
- Always use fully charged batteries.
- Always keep transmitter powered on while aircraft is powered.
- Always remove batteries before disassembly.
- Always keep moving parts clean.
- Always keep parts dry.
- Always let parts cool after use before touching.
- Always remove batteries after use.
- Never operate aircraft with damaged wiring.
- Never touch moving parts.



WARNING: This is a large model helicopter with carbon fiber blades that spin at very high RPM. Always use extreme caution and common sense when maintaining and operating this product. If you are unsure about ANY function or procedure described in this manual, DO NOT operate. Contact Horizon Product Support for assistance.



WARNING: Always ensure you are operating the helicopter a safe distance, 45 feet (13 meters), away from yourself and others.

BLADE® 480 CFX

Table of Contents

Components Needed to Complete	3	Main Rotor Blade Installation	18
Assembly Guide Legend	3	Canopy Installation	18
Tools Needed To Complete	3	Flight Guidelines and Warnings	19
! BEFORE STARTING ASSEMBLY!	4	Flying Your Fusion 480	19
Head Assembly	4	Blade Tracking	19
Frame Assembly	5	Post-Flight Inspection and Maintenance	19
Tail Assembly	11	Troubleshooting Guide	20
Flight Controller Mounting	15	Limited Warranty	20
Battery Installation	15	Warranty and Service Contact Information	21
Helicopter Setup	15	Exploded View	84
Main Rotor Alignment	16	Parts List	86
Throttle Hold	16	Recommended Components	87
Control Tests	16	Optional Parts	87
Tail Rotor Blade Installation	18		

Specifications

Length	38.6 in (980mm)
Main Rotor Diameter	43.1 in (1095mm)
Tail Rotor Diameter	9.1 in (232mm)





Components Needed to Complete

Recommended Component	
Motor	Brushless Motor 4320-1300kV (BLH4953)
ESC	Talon 90-Amp 25V BL ESC W/20amp BEC (CSE010009700)
Battery	4400mAh 6S 22.2V 30C LiPo, 10AWG EC5 (EFLB44006S30)
Receiver	AR7210BX DSMX FBL Control System (SPMAR7210BX)
Swash Servos	H6050 Heli Cyclic Servo (SPMSH6050), <i>metal gear servos required</i>
Tail Servo	H6060 Heli Tail Servo (SPMSH6060), <i>metal gear servo required</i>
Charger	DC Li-Po Balancing Charger
Transmitter	DSM2®/DSMX® Compatible Transmitter

Tools Needed To Complete

- Medium strength thread-locking compound
- High strength thread-locking compound
- 1.5mm, 2mm, 2.5mm, 3mm and 4mm hex drivers
- Ball link pliers
- Needle nose pliers
- Pitch gauge
- Metric ruler or calipers

Assembly Guide Legend

	Apply Medium Thread-locking Compound		Loosely Tighten
	Apply High Strength Thread-locking Compound		Fully Tighten
	Apply NO Thread-locking Compound		

To receive product updates, special offers and more, register your product at www.horizonhobby.com

! BEFORE STARTING ASSEMBLY!**STOP**

Many of the major sub-assemblies of the Blade Fusion 480 kit have been pre-assembled at the factory. These sub-assemblies were not assembled with thread-locking compound. **Prior to beginning assembly of the kit**, loosen any pre-assembled screws which are threaded into metal components and apply thread-locking compound. Use only enough thread-locking compound to moisten the threads. Check all pre-assembled components to ensure all fasteners are tight.

STOP**Head Assembly (H)****Step H1**

1. Remove the spindle bolts from the blade grips.
2. Clean the spindle threads and the threads of the 4x12mm spindle bolts with isopropyl alcohol.
3. Apply high strength thread-locking compound and re-install the spindle bolts. Ensure the thread-locking compound does not contact the blade grip bearings.

WARNING: Failure to apply high strength thread-locking compound to the spindle bolts may allow the spindle bolts to work free during operation, which could cause the rotor blades to fly off. Projectile rotor blades pose a serious risk of property damage and may cause severe bodily injury.

4. Remove the linkage balls from the main grip arms and re-install them using medium thread-locking compound.
5. Install the main grip arms to the blade grips using two 3x10mm socket head caps crews per arm and medium thread-locking compound.
6. Remove the 2x5mm socket head cap screws one at a time from the follower arms and re-install with medium thread-locking compound.
7. Install the follower arms to the head block using one 3x20mm socket head cap screw and two washers per arm and medium thread-locking compound. Ensure the thread-locking compound does not contact the bearings of the follower arms. Do not fully tighten at this time.

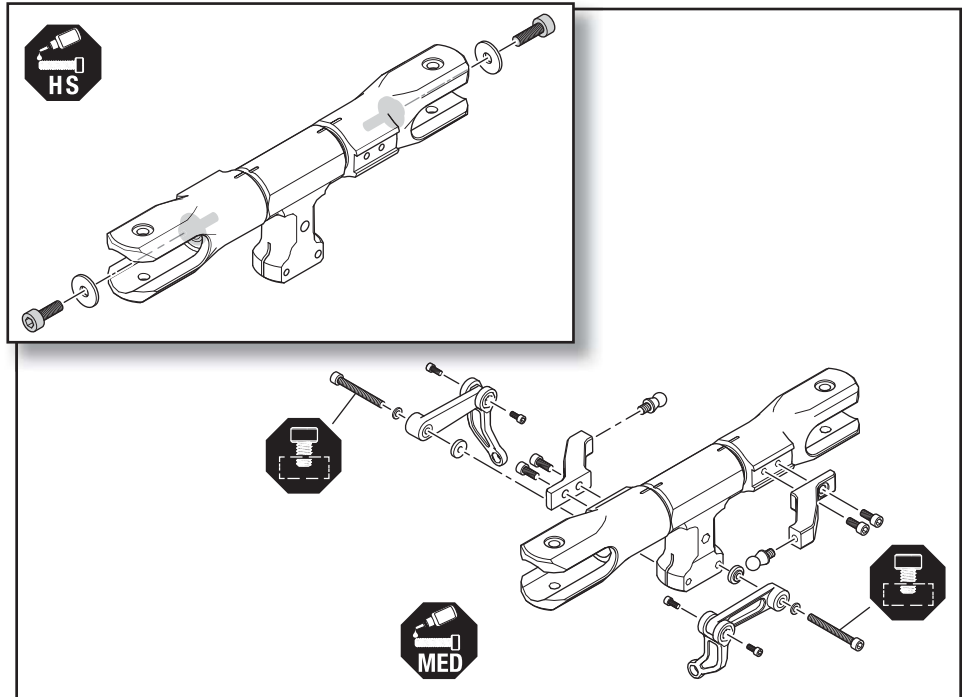
**Step H2**

1. Remove the seven linkage balls from the swashplate assembly one at a time and re-install them with medium thread-locking compound.
2. Fit the swashplate over the main shaft.
3. Insert the main shaft into the head block and secure it with a 4x20mm bolt and locknut. Before tightening the bolt pull on the head block to verify the bolt passes through the hole in the main shaft. **Do not use thread-locking compound on the head bolt and locknut.**
4. Fully tighten the two follower arm 3x20 socket head cap screws installed in step 7 above.

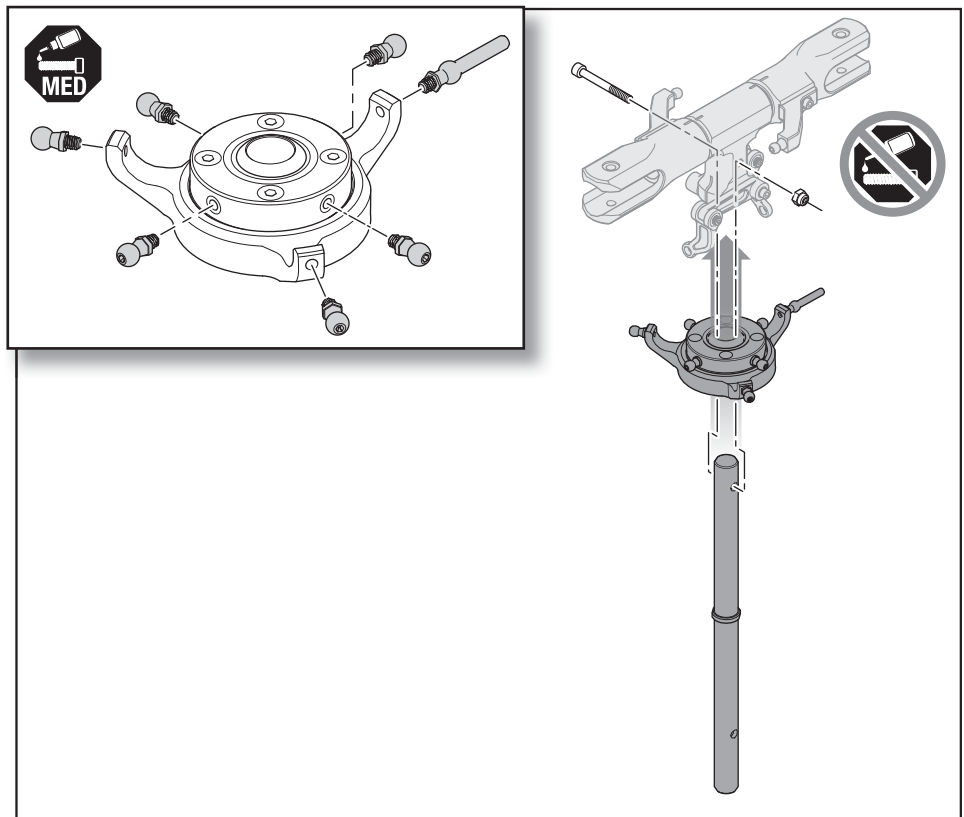

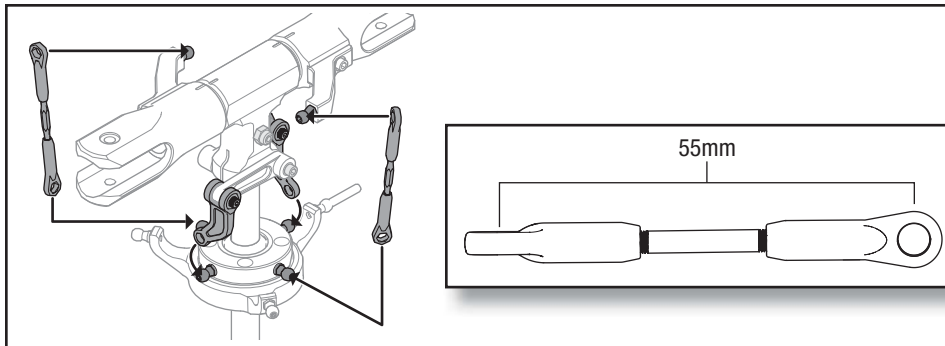

Step H3

1. Snap the follower arms onto two opposite linkage balls on the upper swashplate.
2. Adjust the length of the rotor head linkages to 55mm from center to center of the link openings.
3. Snap the rotor head linkages onto the main grip linkage balls.
4. Snap the other end of the linkages to the remaining linkage balls of the upper swashplate.

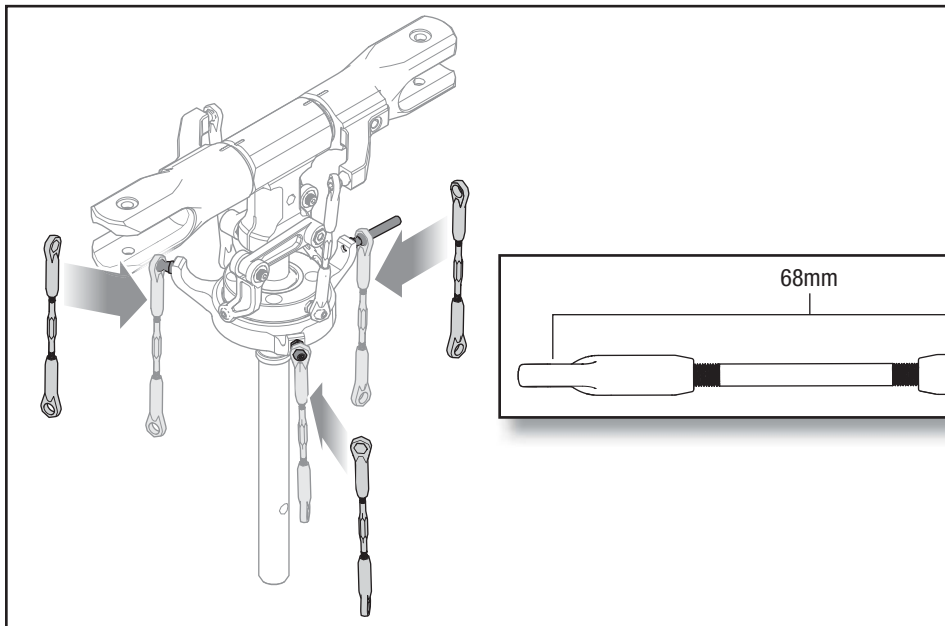

Step H4

1. Adjust the length of the rotor head linkages to 68mm from center to center of the link openings.
2. Snap one end of the servo control linkages onto the linkage balls on the lower swashplate.

Frame Assembly (F)

NOTICE: Always plan your servo wire routing prior to assembly. If servo wires will pass through or cross the frame plates, use sandpaper or a file to smooth the edges of the frame plate to prevent wire chafing. Damage to servo wires may result in loss of control.

CAUTION: Sanding or filing carbon fiber, such as frame plates, may produce carbon dust. Always wear appropriate Personal Protection Equipment (PPE) such as a dust mask, when there is a danger of carbon dust.

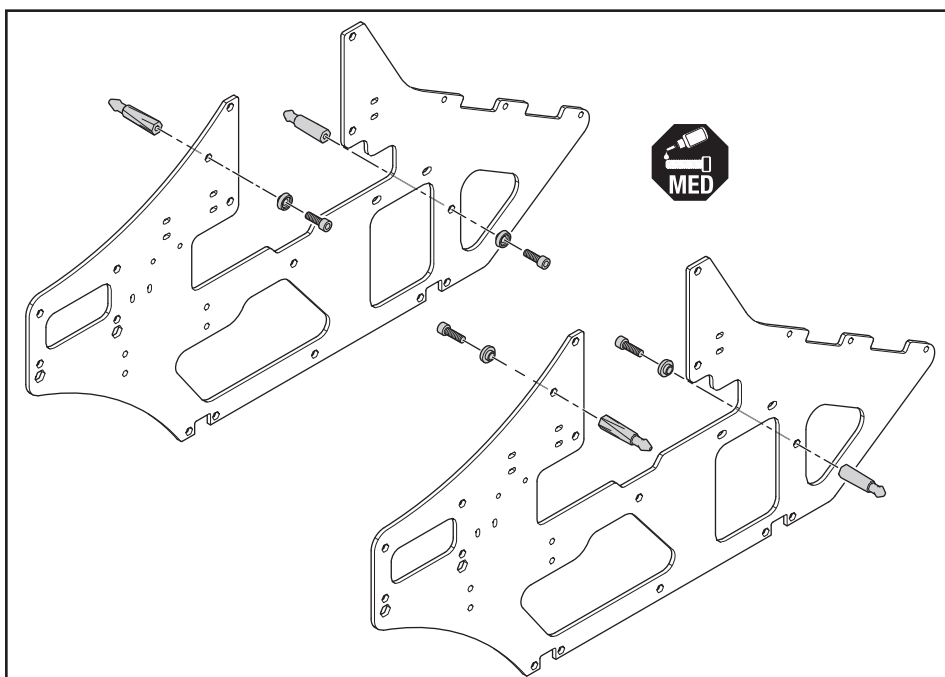

Step F1

Attach two canopy posts to each frame plate using a 3x10mm screw, a machined washer and medium thread-locking compound for each post. Assemble both a left and right frame side as shown in the illustration.

Step F2

1. Attach the upper and lower bearing blocks to the frame sides using 3x10mm screws, machined washers and medium thread-locking compound. The upper block has two threaded holes in the rear of the block. Do not fully tighten the screws in the bearing blocks at this time.
2. Slide the main shaft through both bearing blocks to ensure the blocks are properly aligned with each other.
3. Set the frame sides upright on a flat surface, with the bottom of both sides fully in contact with the work surface.
4. Tighten all of the bearing block screws fully and remove the main shaft from the bearing blocks.
5. Attach two landing gear mounts and two frame posts to the frame sides using 3x10mm screws, machined washers and medium thread-locking compound.

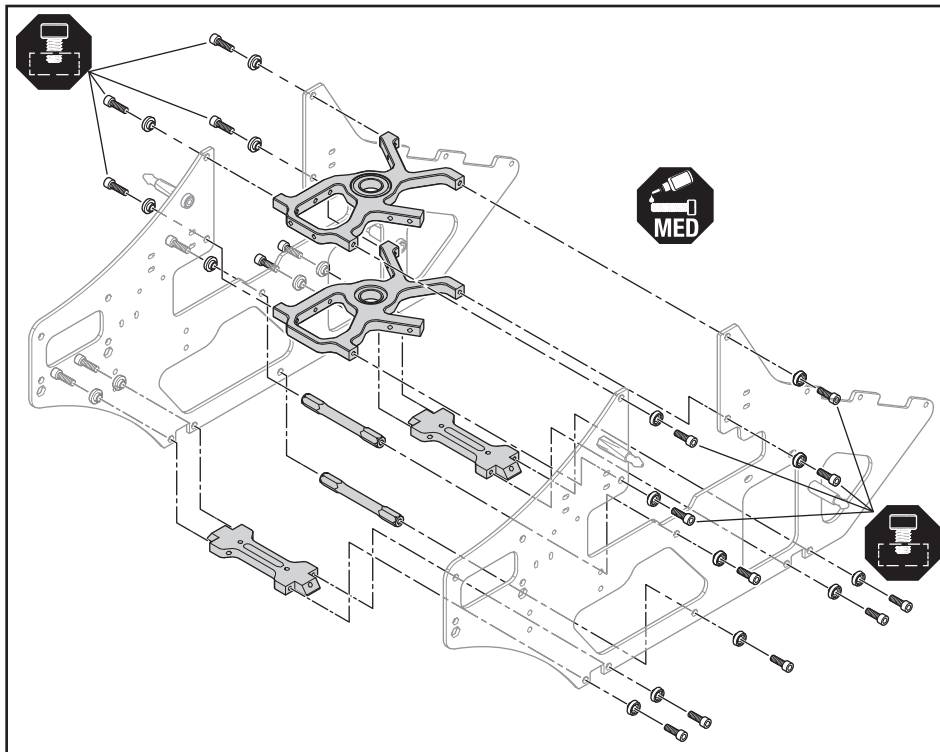

Step F3

Attach the landing gear to each side of the frame using 3x10mm screws, machined washers and medium thread-locking compound.

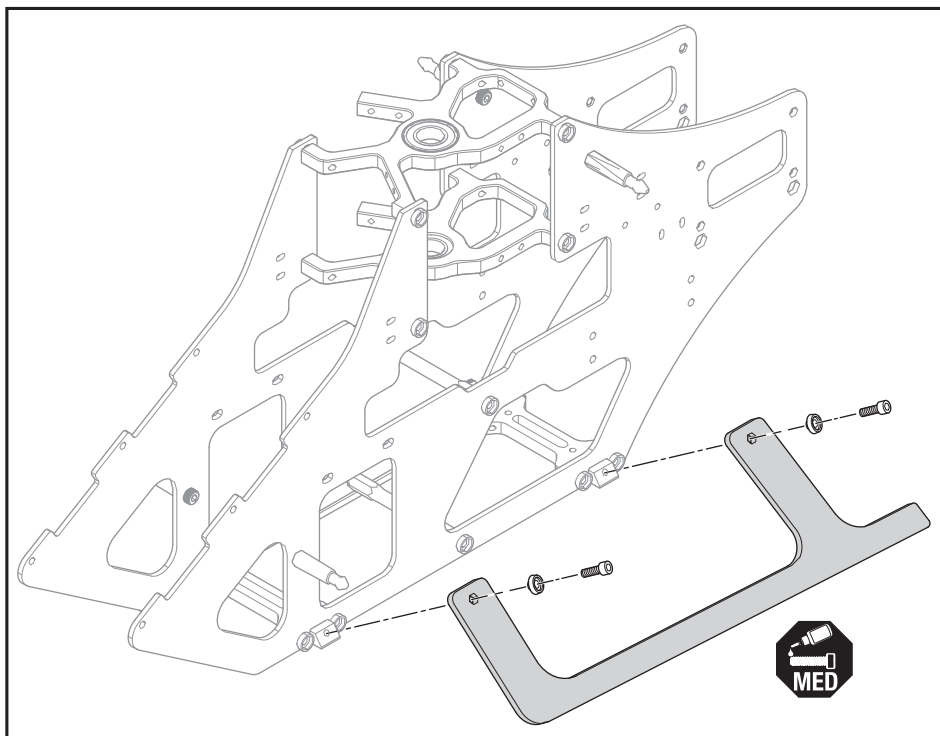

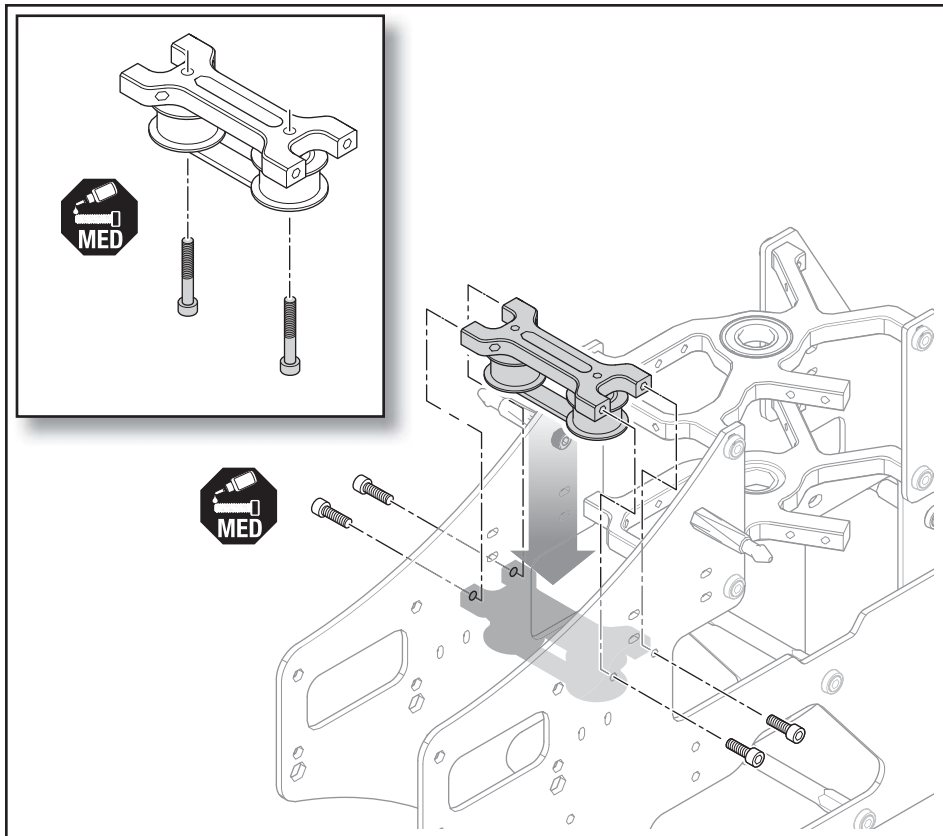

Step F4

1. Remove the 3x18mm socket head cap screws of the tail belt guide assembly and re-install them using medium thread-locking compound. Ensure the thread-locking compound does not contact the bearings of the tail guide assembly.
2. Install the tail belt guide between the frame sides using 3x10mm screws and medium thread-locking compound.

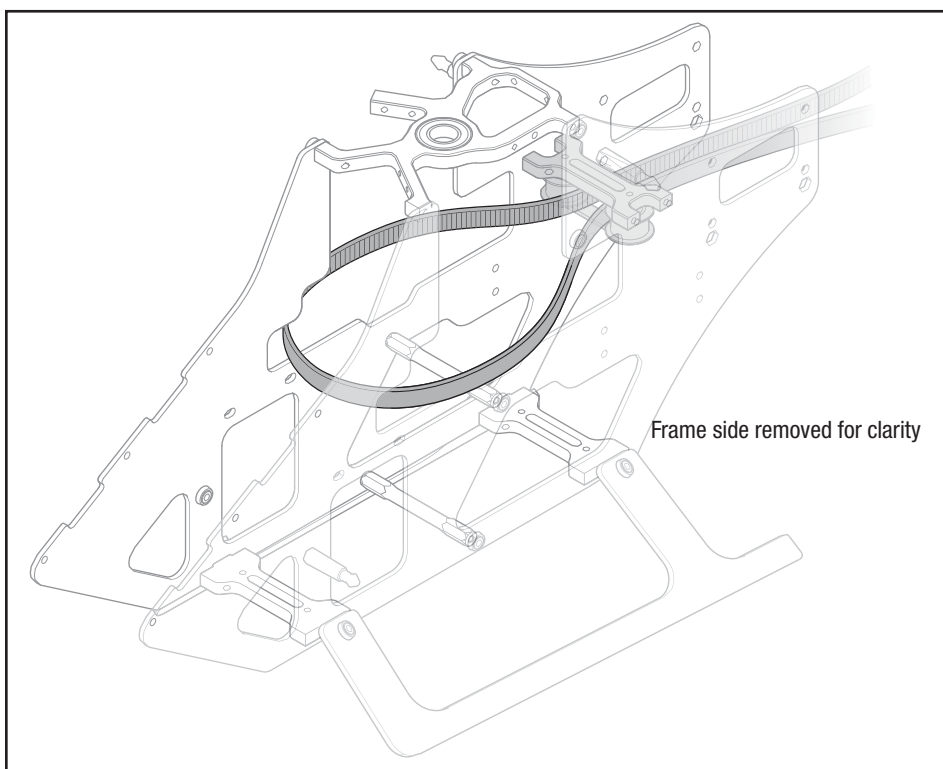

Step F5

- Thread the tail belt through the belt guide with the teeth of the belt facing inward. Pull enough of the belt through the guide to form a large loop, as shown.
Be careful to not crimp the belt.

Step F5

1. Pull the tail belt pulley off of the one-way bearing sleeve. Remove ten 2x4mm flathead screws from the tail drive pulley one at a time and re-install them using medium thread-locking compound.
2. Remove five 3x6mm flathead screws one at a time from the main gear and re-install them using medium thread-locking compound. Re-install the tail belt pulley on the one-way bearing sleeve, ensuring the hole in the pulley aligns with the holes in the sleeve.
3. Slide the main gear assembly through the side of the frame.
4. Place the tail belt around the upper gear as shown.
5. Slide the rotor head assembly down through both bearing blocks and the main gear assembly.
6. Secure the main gear to the main shaft using a 4x20mm bolt and lock nut. **Do not use thread-locking compound on the bolt and lock nut.**
7. Attach the anti-rotation bracket to the back of the upper bearing block using two M3x6mm button head screws and medium thread-locking compound. Ensure the anti-rotation pin is facing the rear of the frame and is inserted in the bracket before securing the bracket to the bearing block.
8. Rotate the rotor head to ensure it rotates freely.

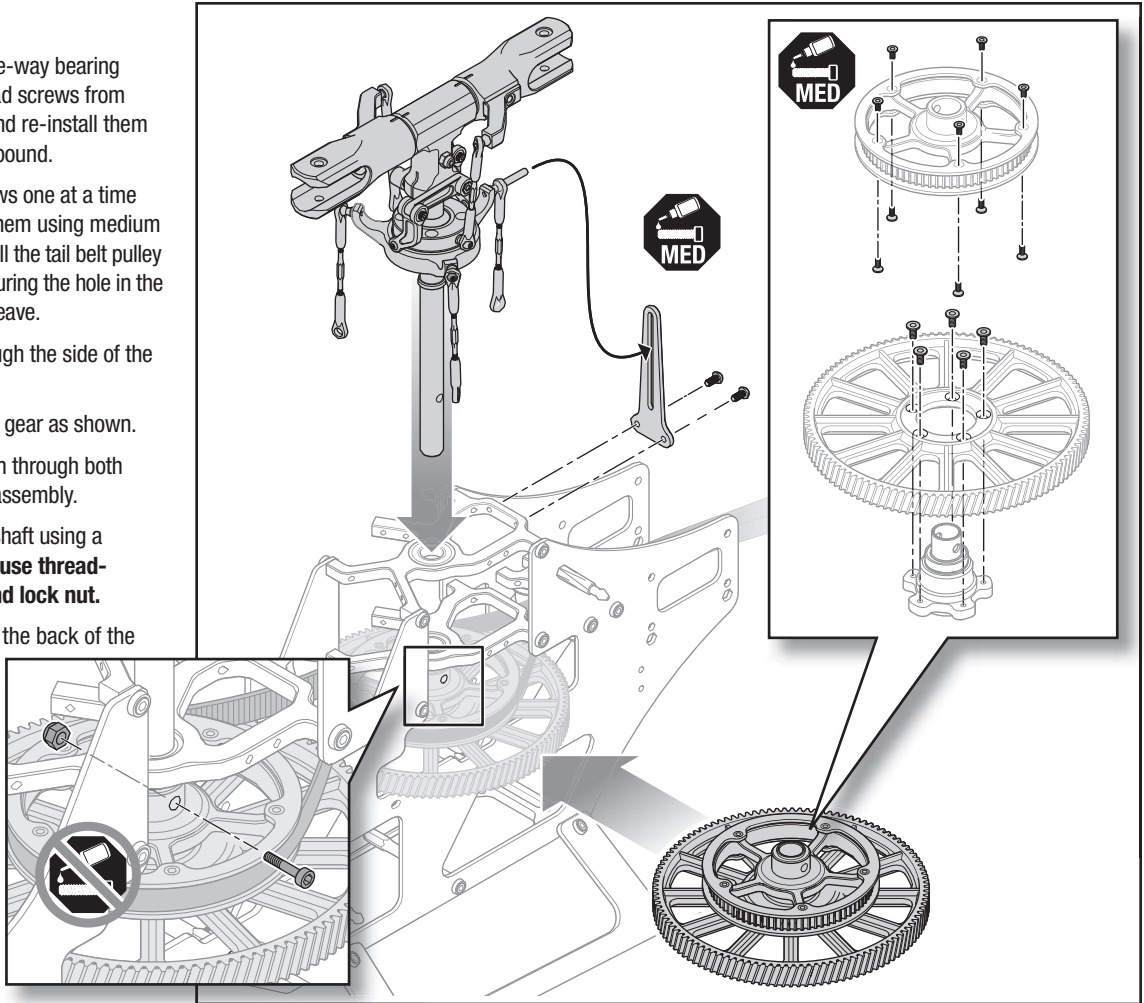

Step F6

1. Attach your chosen motor to the motor mount using four 3x8mm screws and medium thread-locking compound. The motor leads should face toward the front of the aircraft when installed.
2. Attach the pinion gear to the motor shaft using two 4x4mm setscrews and **high strength thread-locking compound**.
3. Prepare the motor leads for connecting to the speed control. If using the recommended speed control, solder the large bullet connectors to the motor leads.
4. Attach the motor mount assembly between the frame sides using M3x10mm screws, machined frame doublers and thread-locking compound.

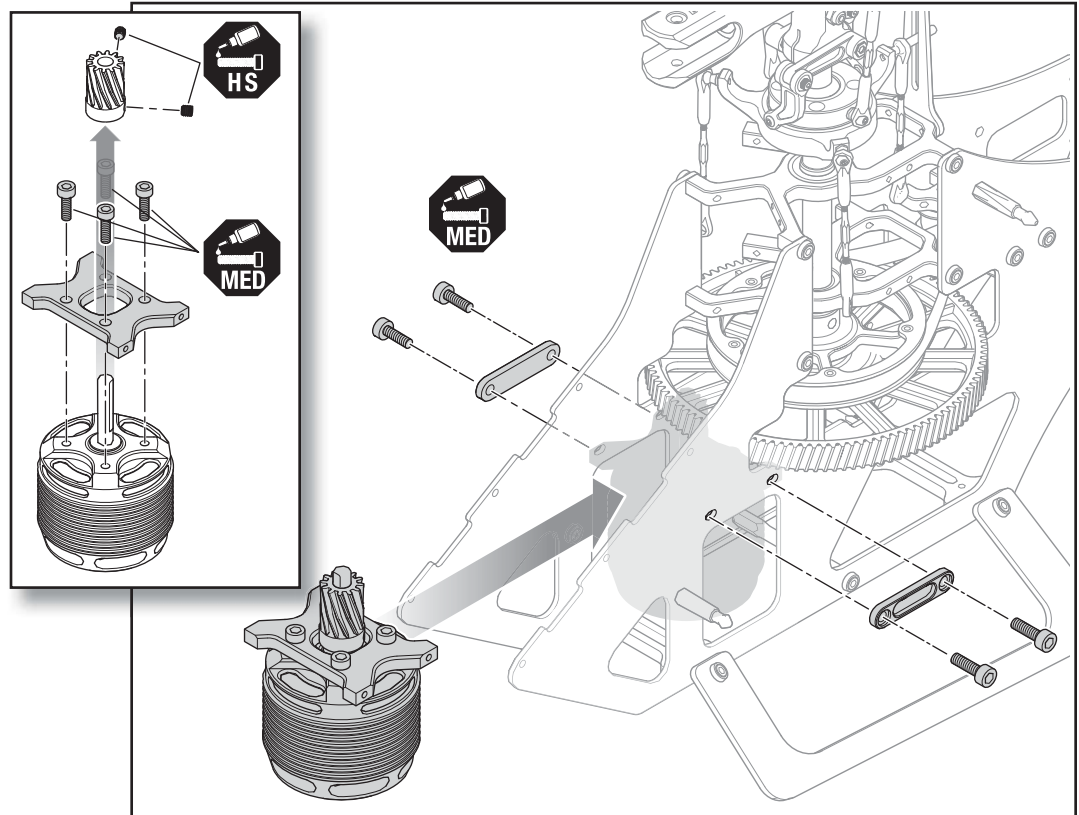

Step F7

1. If using the recommended speed control, attach the speed control mount, included with the speed control, to the bottom side of the battery plate. Secure a hook and loop strap between the battery plate and the speed control mount, as shown.

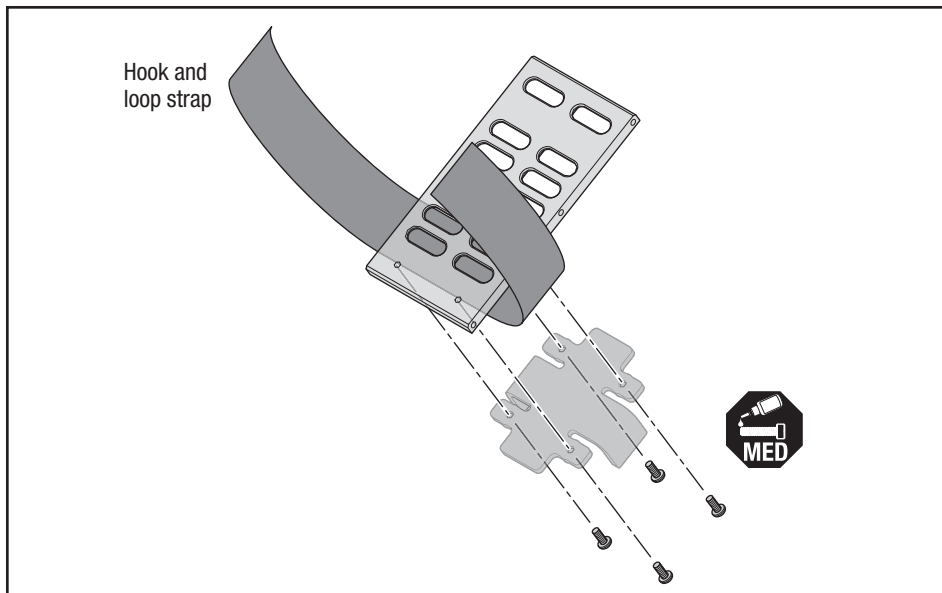

2. Clip the speed control in the speed control mount.

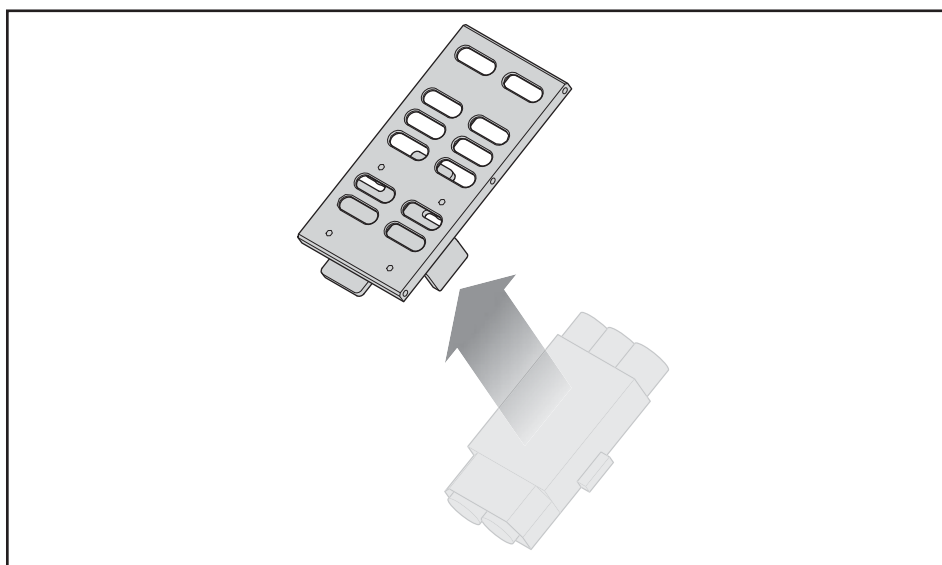

3. Connect the motor leads to the speed control.
4. Attach the battery mounting plate between the frame sides using six 3x10mm screws and medium thread-locking compound. Place a second hook and loop strap under the plate. The straps should exit through the gaps in the frame sides.

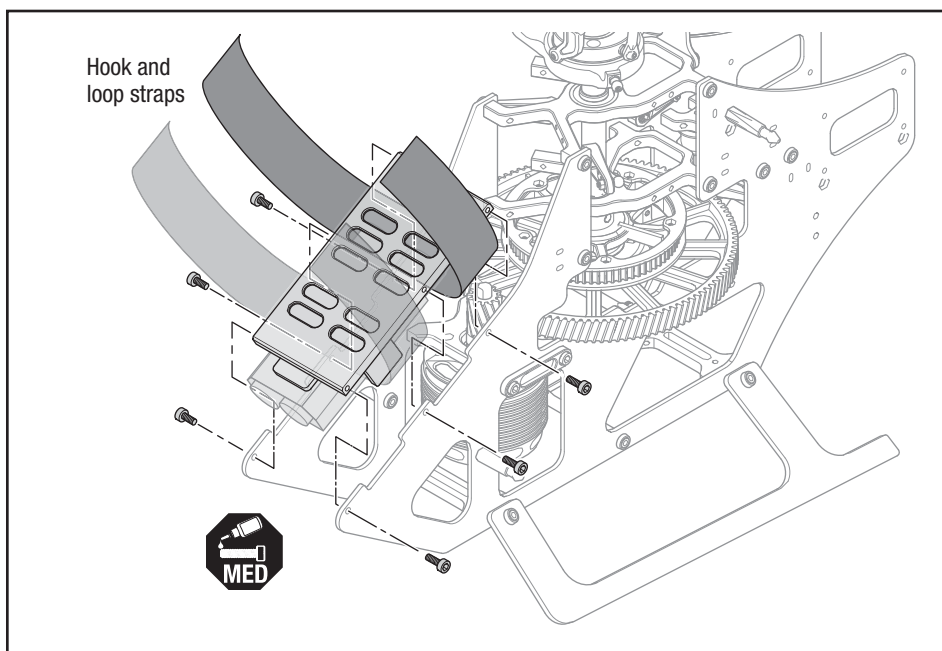

Step F8

Prepare three cyclic servos as follows:

1. Center the servos using either your receiver or a servo tester.
2. Attach the servo arm in the position shown, perpendicular to the servo case, using the screw provided with the servo and medium thread-locking compound.
3. Attach the linkage ball to the outer servo arm location using an M2 nut.
4. Attach the servos to the bearing blocks, in the positions shown using 3x10mm button head screws and medium thread-locking compound.
5. Press the bottom end of the servo linkages on the servo arm linkage balls.

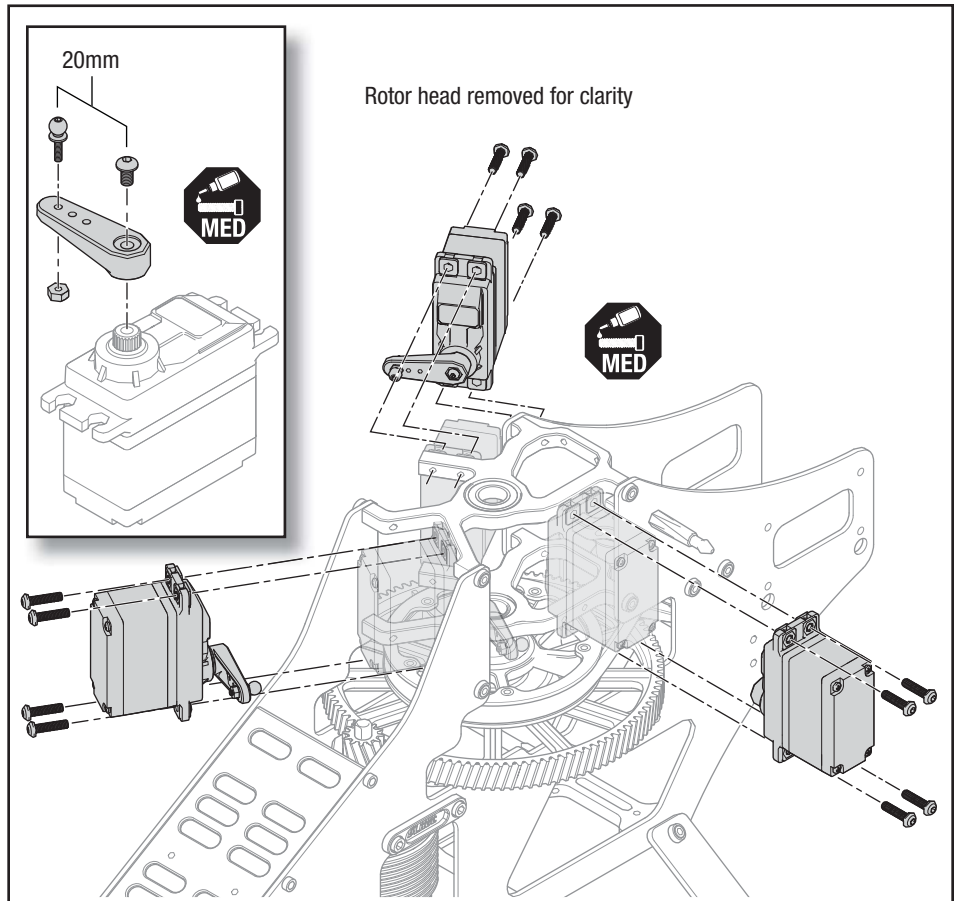

Step F9

Prepare the tail servo as follows:

1. Center the servo using either your receiver or a servo tester.
2. Attach the servo arm in the position shown, perpendicular to the servo case, using the screw provided with the servo and medium thread-locking compound.
3. Attach the linkage ball to the middle servo arm location, using an M2 nut.
4. Attach the tail servo mounts to the servo using M3x8mm button head screws and thread-locking compound. Do not fully tighten the servo mount screws.
5. Attach the tail servo assembly to the inside of the right frame side as shown, using four 3x10mm screws, machined washers and medium thread-locking compound.
6. Fully tighten the servo mount screws.

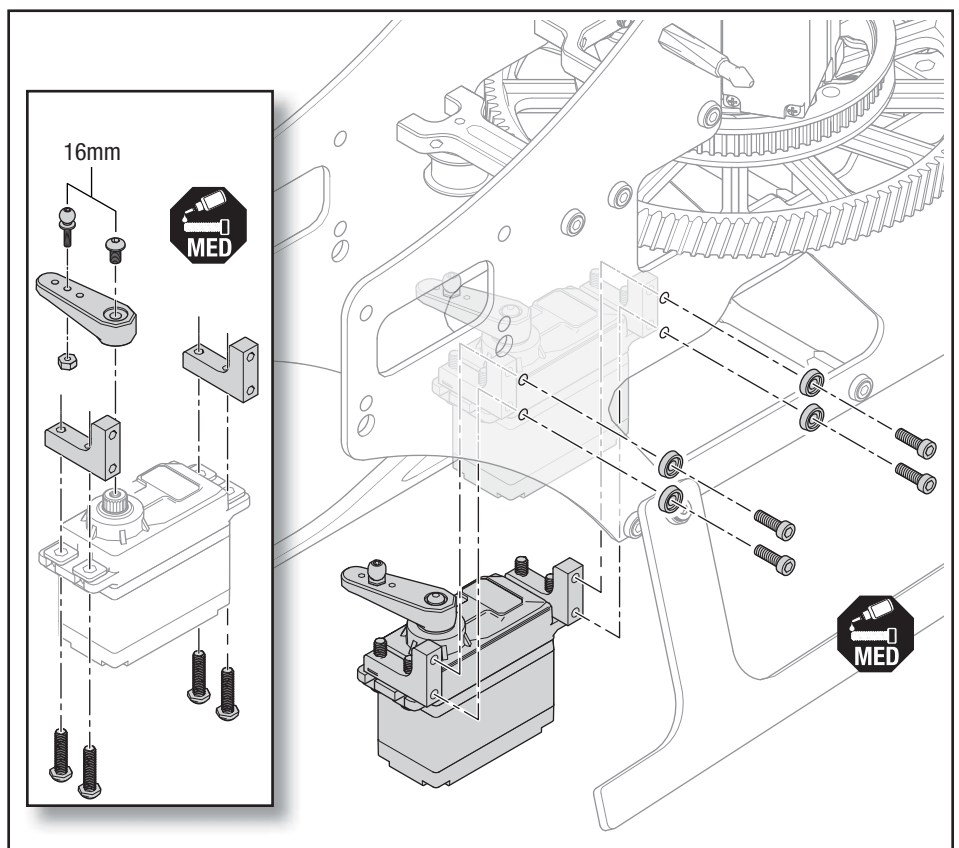

Tail Assembly (T)

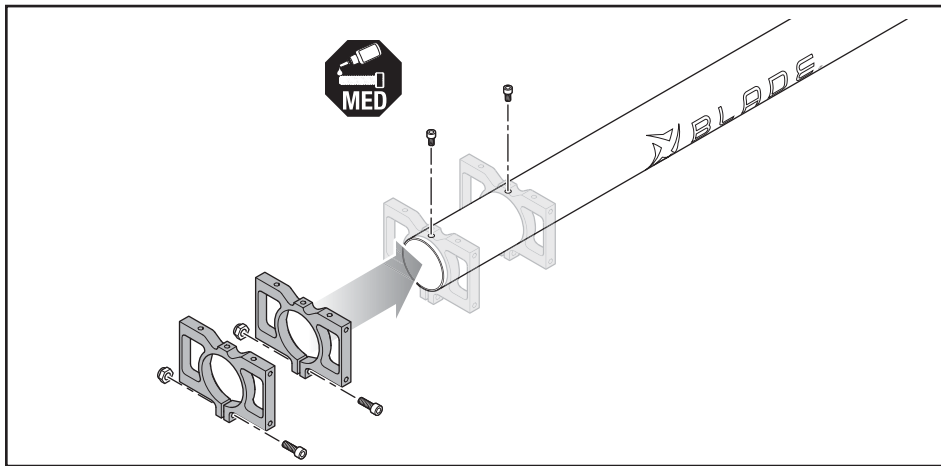

Step T1

1. Slide two front tailboom mounts over the front of the tail boom. The Blade® logo is towards the front of the tailboom.
2. Attach the mounts to the tailboom using one M3x6mm button head screw per mount and medium thread-locking compound, into the holes in the top of the tailboom.
3. Loosely insert a 3x12mm screw and locknut into the bottom of each mount. Do not use thread-locking compound. Do not fully tighten.

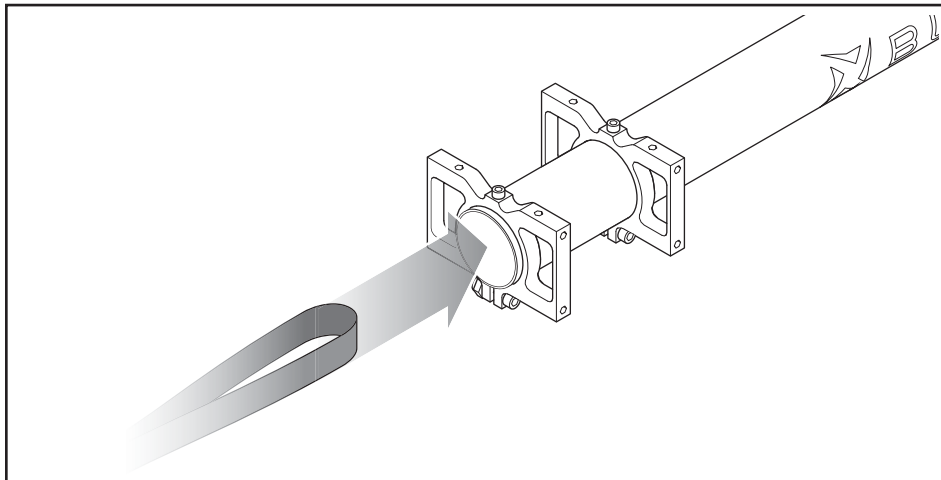

4. Insert the free end of the tail belt through the tailboom.

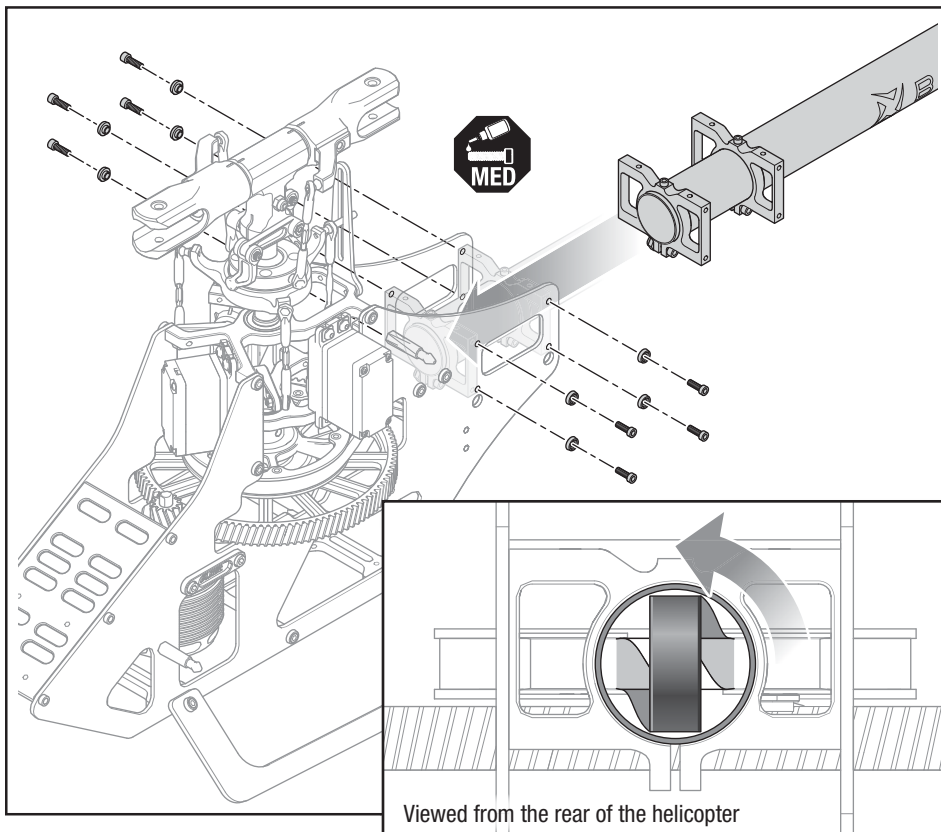

5. Feed the belt through the boom as you slide the boom mounts between the frame sides.
6. Attach the boom mounts to the frame sides using 3x10mm screws, machined washers and medium thread-locking compound.
7. Fully tighten the 3x12mm boom mount screws and locknuts installed in Step 3 above.
8. When the boom is fully seated in place, the tail belt should extend from the back of the boom as shown. Rotate the rear loop of the belt 90° counter-clockwise from horizontal, when viewed from the rear of the aircraft. Ensure the belt is not twisted inside the boom.

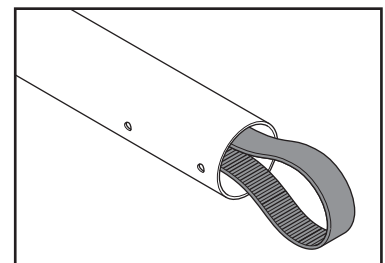

Tail Assembly (T)

Step T2

1. Slide the tail pushrod guide onto the tailboom. The guide should be located approximately in the center of the tailboom.
2. Slide two rear tailboom mounts over the tailboom.
3. Attach the mounts using two 3x6mm button head screws per mount and medium thread-locking compound, into the holes on either side of the tailboom.
4. Loosely insert one 3x10mm socket head capscrew with medium thread-locking compound in the top of each mount as shown.

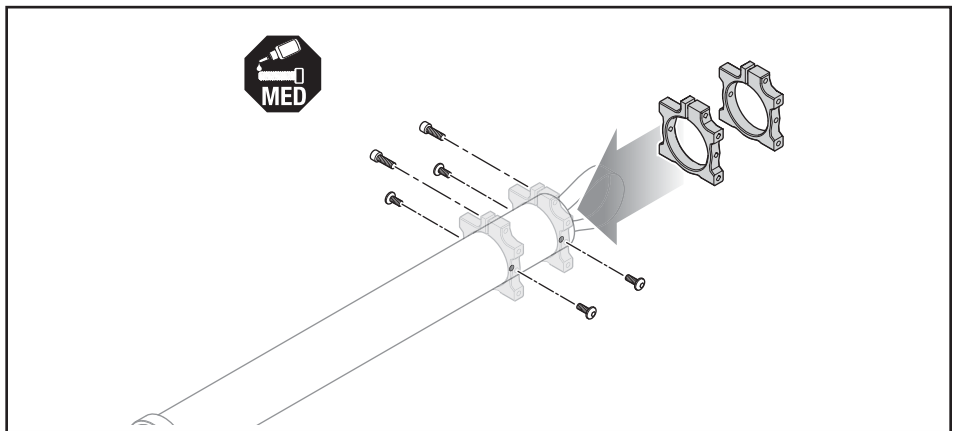
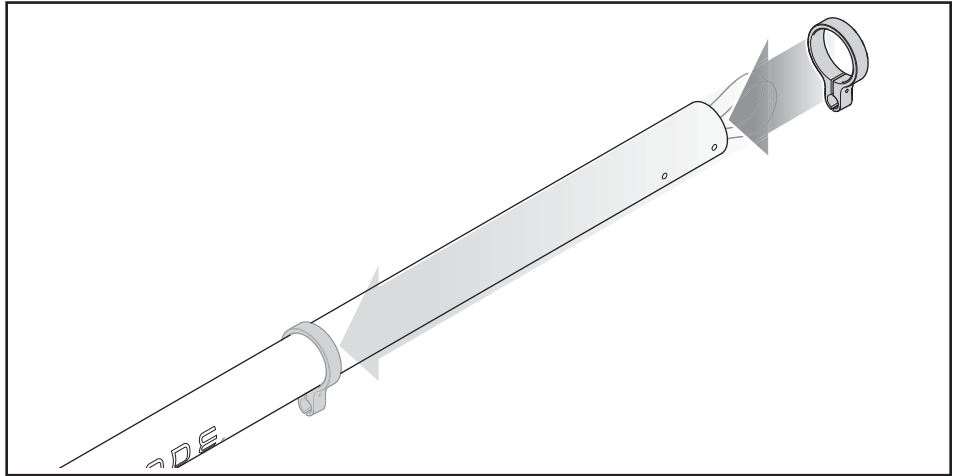

Step T3

1. Remove the 3x16mm socket head cap screw and linkage ball from the tail pitch lever assembly and re-install them using medium thread-locking compound. Ensure the thread-locking compound does not contact the lever assembly bearings.
2. Attach the tail rotor pitch lever assembly to the right side tail plate using two 2.5x8mm button head screws and medium thread-locking compound.
3. Attach the right tail plate assembly to the tailboom mounts using four 3x10mm socket head capscrews, machined washers and medium thread-locking compound. Do not fully tighten.
4. Attach the left side tail plate/fin to the tailboom mounts using four 3x10mm socket head capscrews, machined washers and medium thread-locking compound. Do not fully tighten.
5. Insert the tail belt guide bearing between the tail plates and attach with two 2.5x8mm socket head capscrews and medium thread-locking compound.
6. Insert the rear spacer post between the tail plates and attach with two 3x10mm socket head capscrews, machined washers and medium thread-locking compound.

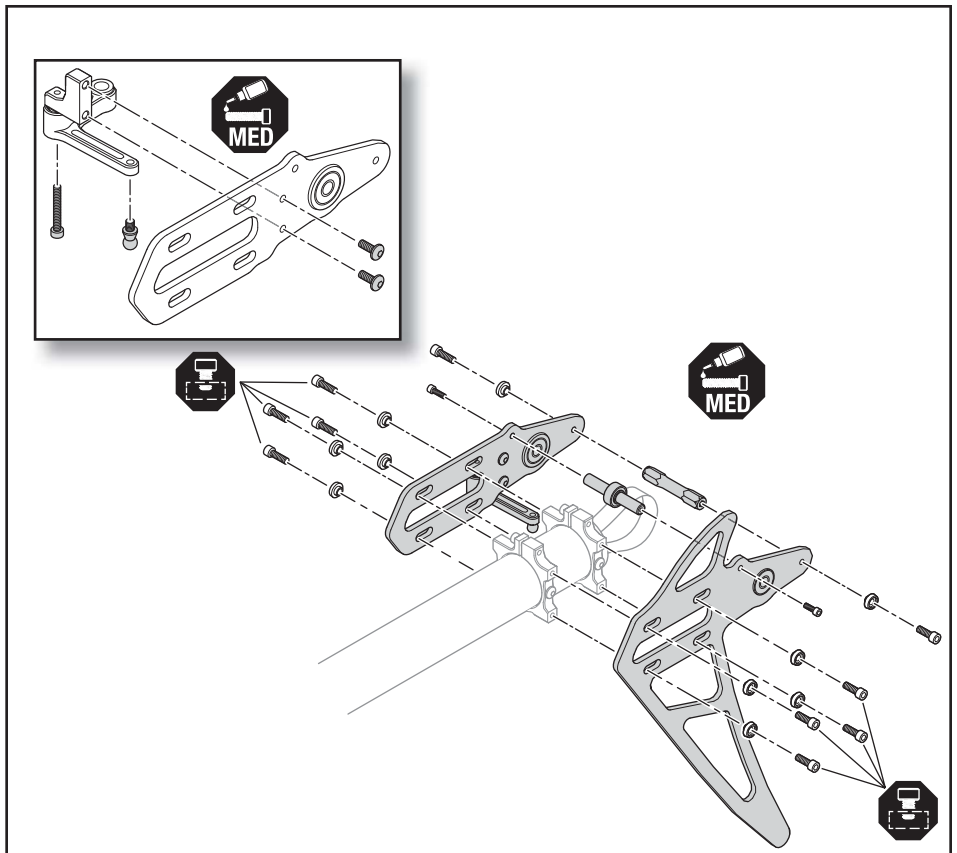

Tail Assembly (T)

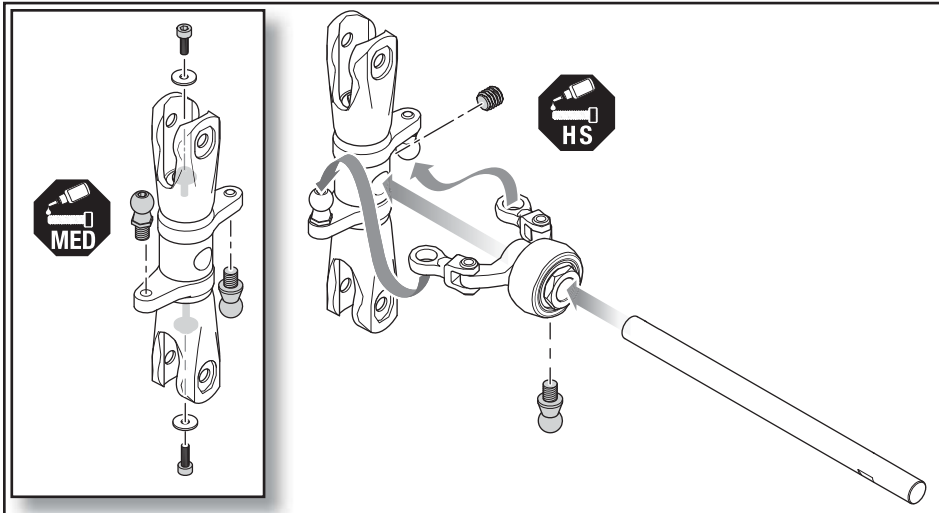

Step T4

1. Remove the tail grip retention screws and linkage balls and re-install them using medium thread-locking compound. Ensure the thread-locking compound does not contact the tail grip bearings.
2. Insert the tail shaft into the tail rotor hub assembly.
3. Lock the tail shaft into place with a M4x4mm setscrew and **high strength thread-locking compound**. Ensure the setscrew contacts the flat area machined into the tail shaft.
4. Remove the linkage ball from the pitch slider assembly and re-install using medium thread-locking compound.
5. Slide the pitch slider assembly over the tail shaft and snap the ball links onto the tail grip linkage balls.

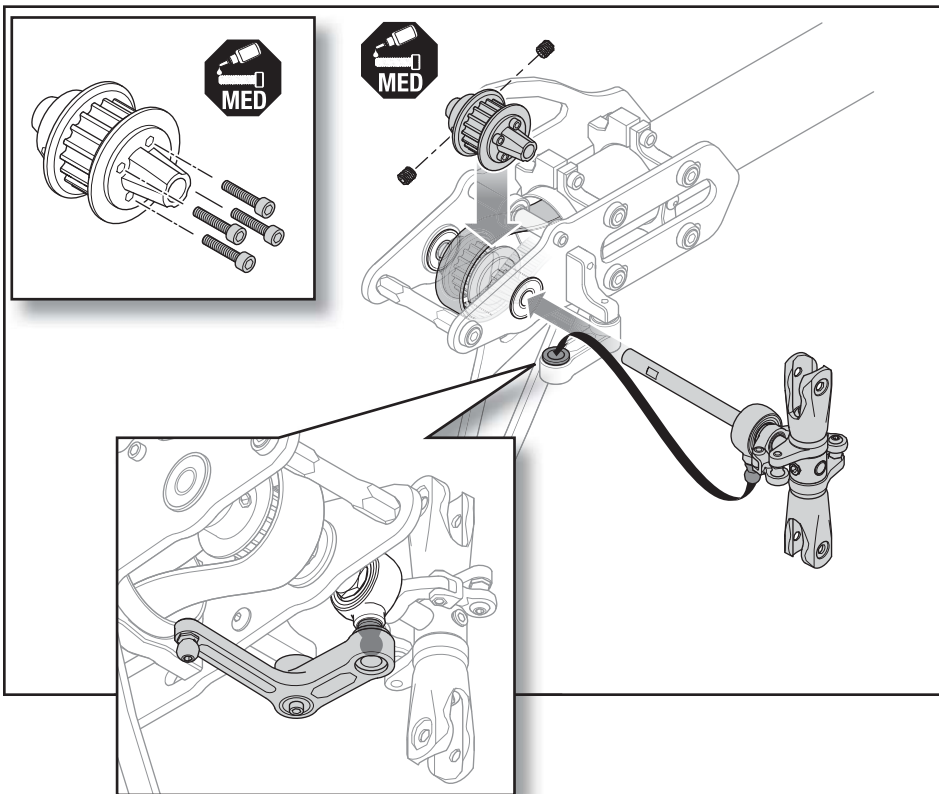

Step T5

1. Remove four 2x16mm cap head screws from the tail pulley one at a time and re-install using medium thread-locking compound.
2. Insert the tail pulley into the loop created by the tail belt, as shown.
3. Slide the tail shaft in from the right side, through the tail pulley and into the left side tail plate bearing. As you slide the tail shaft in, insert the linkage ball of the tail pitch slider into the nylon bushing of the tail rotor bell crank.
4. The tail shaft should extend out of the left side plate bearing by approximately 1mm.
5. Secure the tail pulley to the tail shaft using two 4x4mm setscrews and medium thread-locking compound. Ensure the setscrews are in contact with the flat areas machined into the tail shaft.

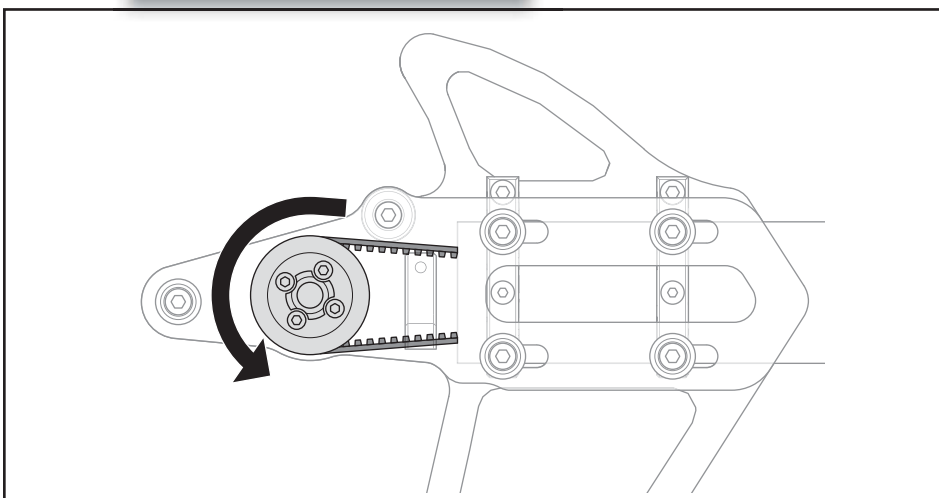

Check the rotation of the tail pulley. The tail pulley should rotate as shown when the main rotor is rotated clockwise, when viewed from above. If the tail gear does not rotate as shown, remove the tail shaft and tail pulley, rotate the tail belt loop 180° and re-assemble. **Sight down the tail boom and ensure the tail belt is not twisted more than 90° inside the tail boom.**

Tail Assembly (T)

Step T6

1. Check the belt tension just behind the main gear at the rear of the side plate opening. Push inward on the belt from the side with moderate pressure. The belt should not deflect more than 4mm.
2. Set the tail belt tension by applying pressure against both tail side plates towards the rear of the aircraft. Fully tighten the eight 3x10mm screws holding the tail side plates to the rear boom mounts.

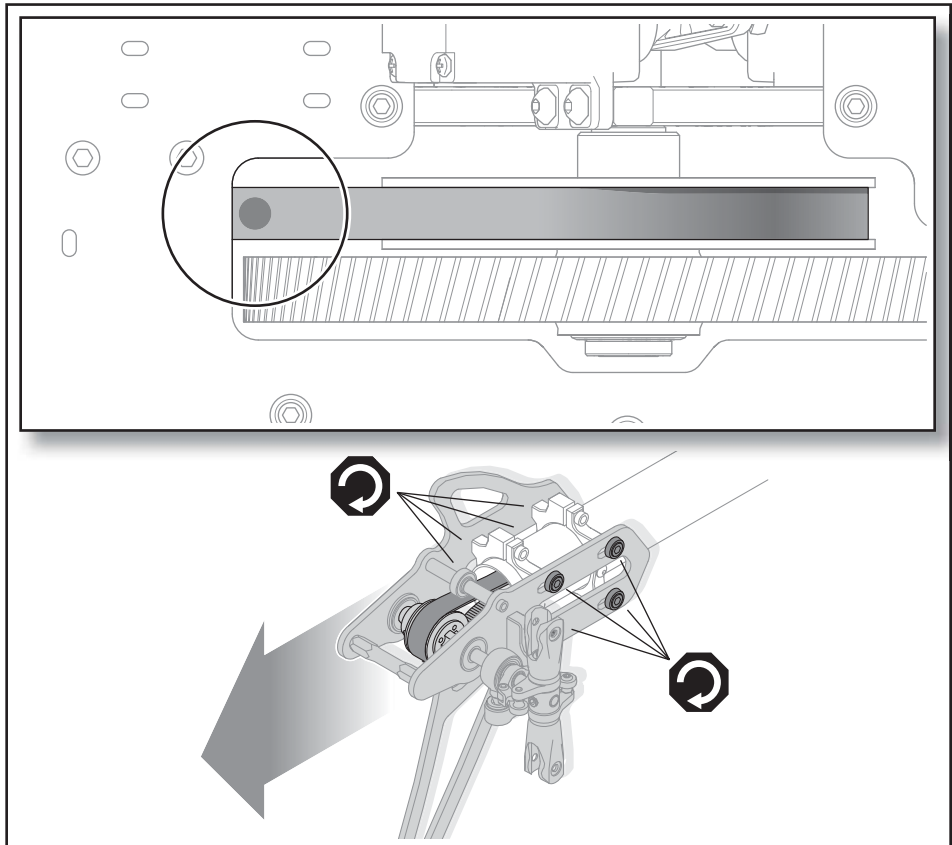

Step T7

1. Insert the metal sleeve of the tail pushrod into the pushrod guide.
2. Secure the pushrod guide with a socket head cap screw.
3. Snap the front tail pushrod linkage onto the tail servo arm.
4. Snap the rear pushrod linkage onto the tail rotor pitch lever.

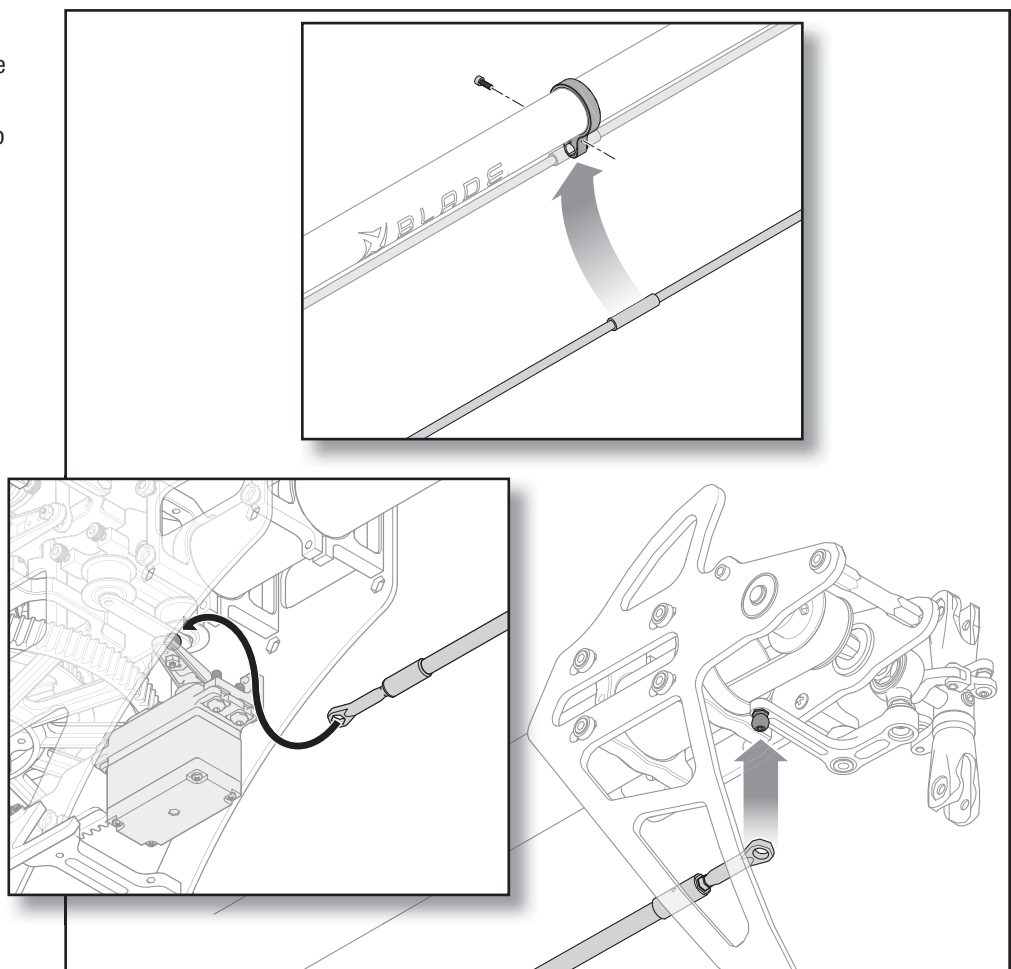

Flight Controller Mounting

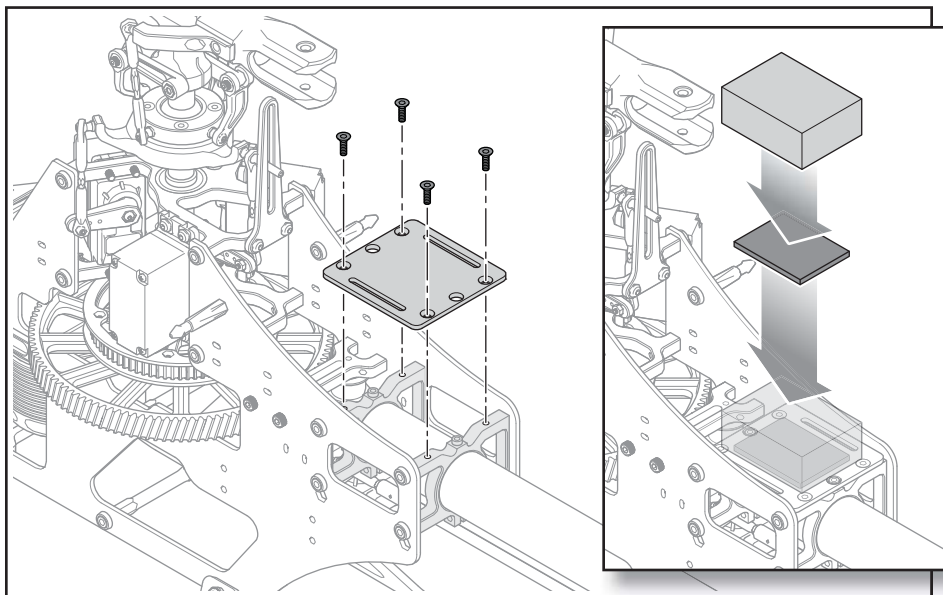

1. Route the servo and throttle wires to the flight controller mounting area of the frame. Small holes are provided in the frame side plates to allow for securing the servo wires with small plastic cable ties. When routing the wires, be very careful to avoid any moving parts and sharp edges of the carbon fiber plates.
2. Attach the flight controller mounting plate to the top of the front tail boom mounts using four M3x6mm flathead screws and thread-locking compound.
3. Secure your chosen flybarless flight controller to the mounting plate per the mounting instructions included with your flight controller.
4. Connect the servo and throttle wires to the flight controller.

Battery Installation

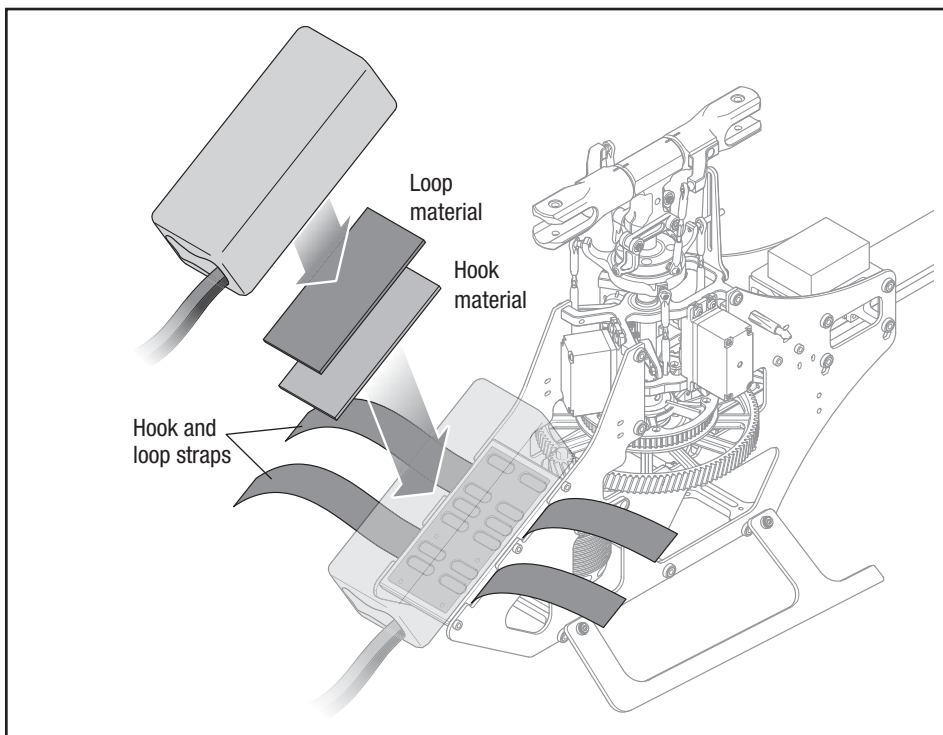

1. Apply the loop side of adhesive backed hook and loop material to the flight battery.
2. Apply the hook side to the battery plate.
3. Attach the flight battery to the battery plate.
4. Secure the battery with the hook and loop straps.

CAUTION: Always disconnect the Li-Po battery from the electronic speed control when not flying to avoid over-discharging the battery. Batteries discharged to a voltage lower than the lowest approved voltage may become damaged, resulting in loss of performance and potential fire when batteries are charged.

Helicopter Setup

The following are optimal settings for the Blade Fusion 480, obtained through extensive flight testing. Refer to your flybarless flight controller and transmitter manuals for proper setup.

Collective Pitch Range
Normal, -12 degrees to +12 degrees (adjust to suit your preferences)

Head Speed		
Flight Mode	11t Pinion	Optional 12t Pinion (only recommended for 65C batteries)
Normal	2100	2100
Stunt 1	2350	2550
Stunt 2	2550	2750

Main Rotor Alignment

With the servos centered and arms level, the swashplate should be level and the 0 degree collective indication marks on top of the blade grips and headblock should align, as shown. Adjust the lengths of the blade grip linkages and servo linkages until everything is aligned properly.

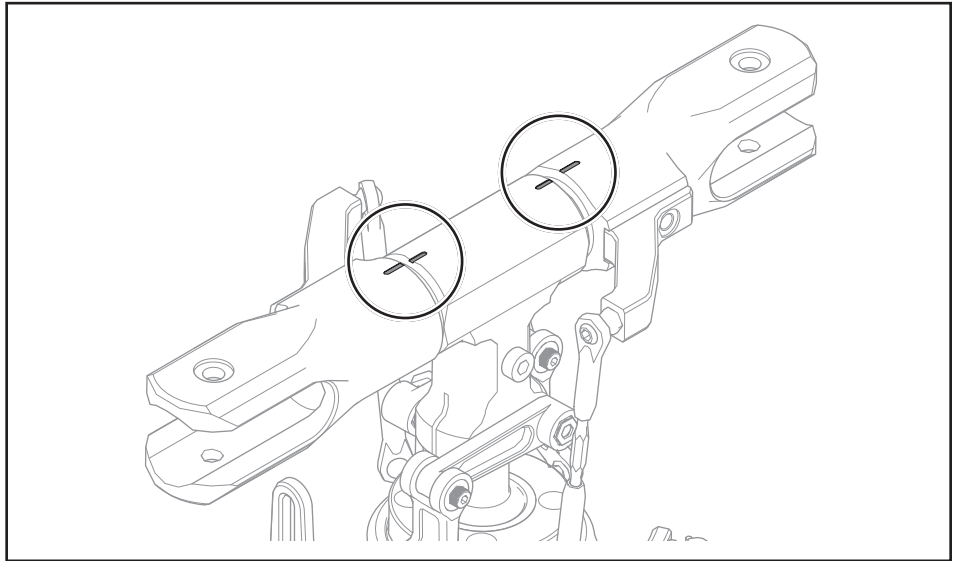

Throttle Hold

Activating and using the Throttle Hold (TH HOLD) function in your chosen transmitter is highly recommended. Throttle hold only cuts power to the motor on an electric helicopter. Pitch and direction control are maintained.



WARNING: If your transmitter has throttle hold, always engage throttle hold before approaching the helicopter for any reason.

The blades will spin if TH HOLD is OFF. For safety, turn TH HOLD ON any time you need to touch the helicopter or check the direction controls.

Additionally, turn TH HOLD ON to cut power to the motor if the helicopter is out of control, in danger of crashing, or both.

Control Tests



CAUTION: You must complete the Rudder and Cyclic tests prior to attempting flight. Failure to ensure the sensor directions are not reversed can cause the helicopter to crash, resulting in property damage and injury.

Rudder

1. Power on the transmitter.
2. Turn TH HOLD ON and set the flight mode to NORMAL.
3. Connect the helicopter battery to the ESC and allow the flight controller to fully initialize.
4. **Rudder channel test:**
Move the rudder stick to the right. The tail pitch slider should move towards the tail boom.
Move the rudder stick to the left. The tail pitch slider should move away from the tail boom.
If the slider does not move in the desired direction, refer to your flight controller manual for instructions to correct the issue.
5. **Flight controller sensor test:**
Release the rudder control. Manually turn the helicopter counterclockwise when viewed from above. The tail pitch slider should move towards the tail boom.
Manually turn the helicopter nose clockwise. The tail pitch slider should move away from the tail boom.
If the slider does not react in the proper direction, refer to your flight controller manual for information on reversing the tail sensor direction.

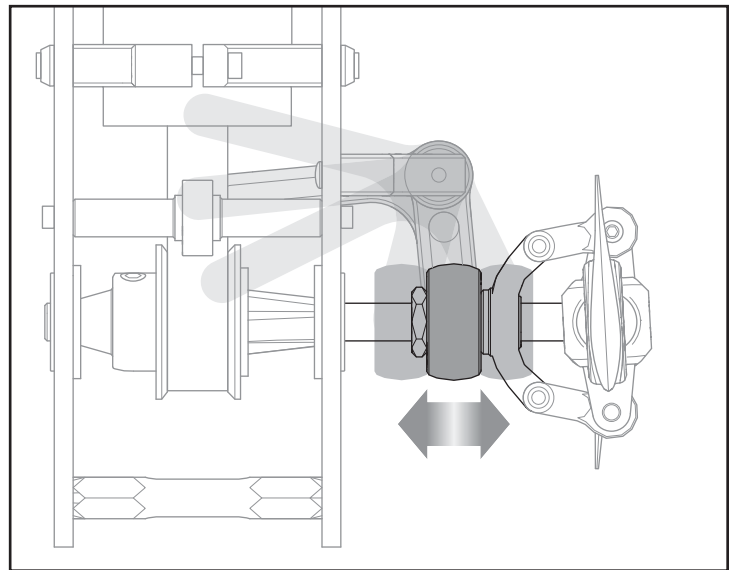

Cyclic Sensor Test

From the back of the helicopter:

1. Tilt the helicopter forward. The swashplate should tilt backward.
2. Tilt the helicopter backward. The swashplate should tilt forward.
3. Roll the helicopter left. The swashplate should roll right.
4. Roll the helicopter right. The swashplate should roll left.
5. If the swashplate does not move in the correct direction, you will need to reverse the cyclic sensor direction or sensor orientation setting. Refer to the flight controller manual for information.

Thoroughly review your chosen flight control system manual to ensure the system is configured properly, per the manufacturer's recommendations.

WARNING: Disconnect the motor from the electronic speed control or ensure the transmitter throttle hold function is properly configured and ON prior to performing the cyclic and collective control tests. Failure to do so will allow the motor to start unexpectedly and may cause serious property damage or bodily injury.

Cyclic and Collective Control Test

Turn TH HOLD ON when conducting the control tests. Increasing Collective Pitch while TH HOLD is off will cause the motor to engage and the rotors to spin.

Elevator, Forward and Back Cyclic

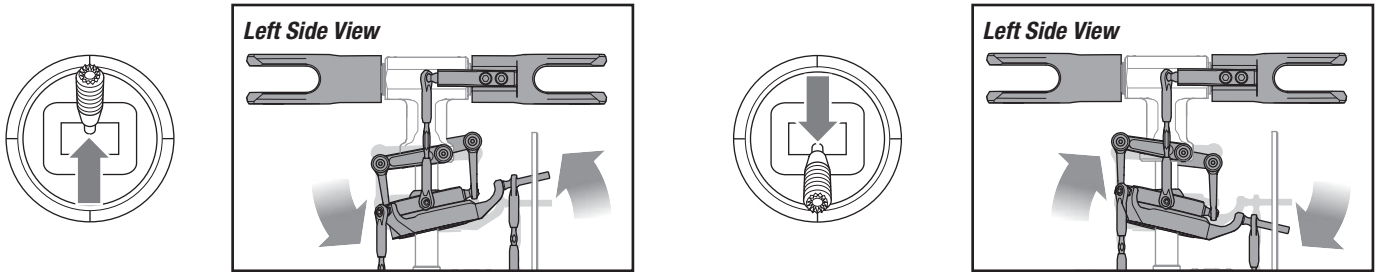

Aileron, Left and Right Cyclic

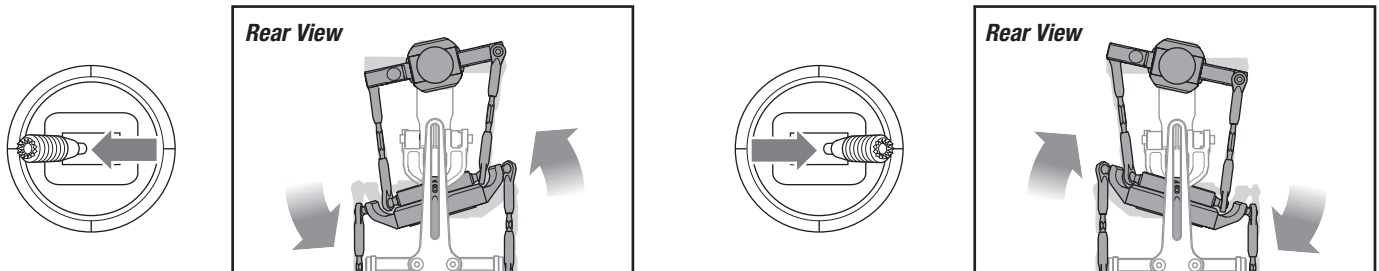

Collective Pitch

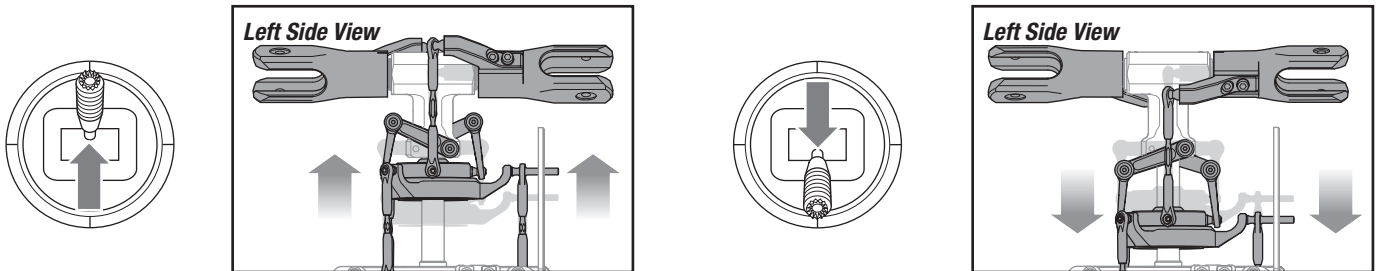

Motor Direction Test

Place the helicopter outdoors on a clean, flat and level surface (concrete or asphalt) free of obstructions. Always stay clear of rotating parts.

1. Power on the transmitter. Make sure TH HOLD is ON and the flight mode switch is set to NORMAL.

2. Lower the throttle completely.
3. Connect the Li-Po battery to the ESC.

4. Turn TH HOLD OFF. Slowly increase the throttle until the drive train begins to turn. The main rotor should spin clockwise when viewing the helicopter from the top. The tail rotor should spin counterclockwise when viewing the helicopter from the right side.

NOTICE: If the drive train does not turn with the motor or the main rotor spins counterclockwise, turn TH HOLD ON. Disconnect the battery from the helicopter and reverse any two motor wire connections to the ESC and repeat the motor control test.

Tail Rotor Blade Installation

Install the tail blades in the orientation shown using 3x12mm bolts and locknuts. **Do not apply thread lock compound to the bolt and lock nut.**

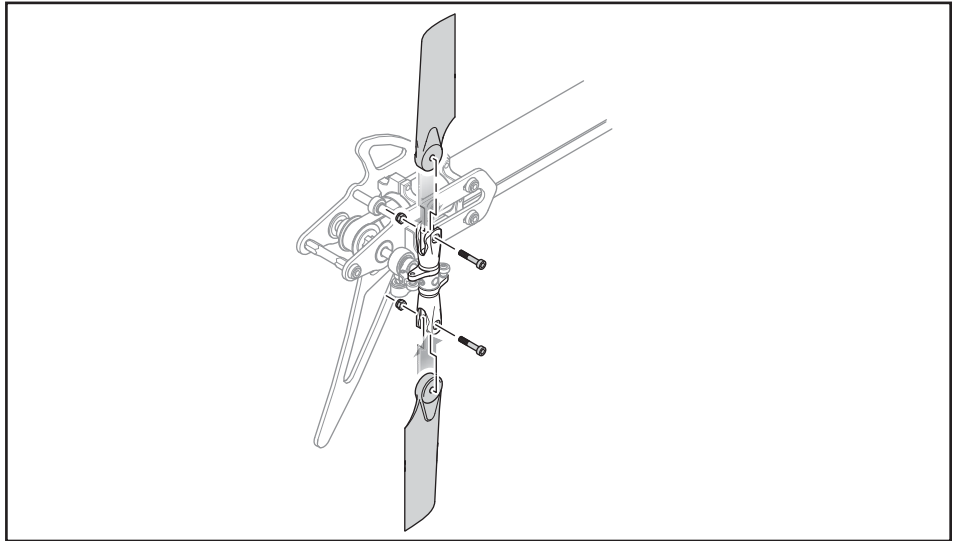

Main Rotor Blade Installation

Install the main rotor blades in the orientation shown using 4x30mm bolts, plastic blade shims and locknuts.

Do not apply thread lock compound to the bolt and lock nut.

Do not over-tighten.

- The rotor blades should be tight enough to hold their position if you hold the helicopter sideways and remain in position even if the helicopter is shaken abruptly. The exact tension is not as important as ensuring both blades are at the same tension.

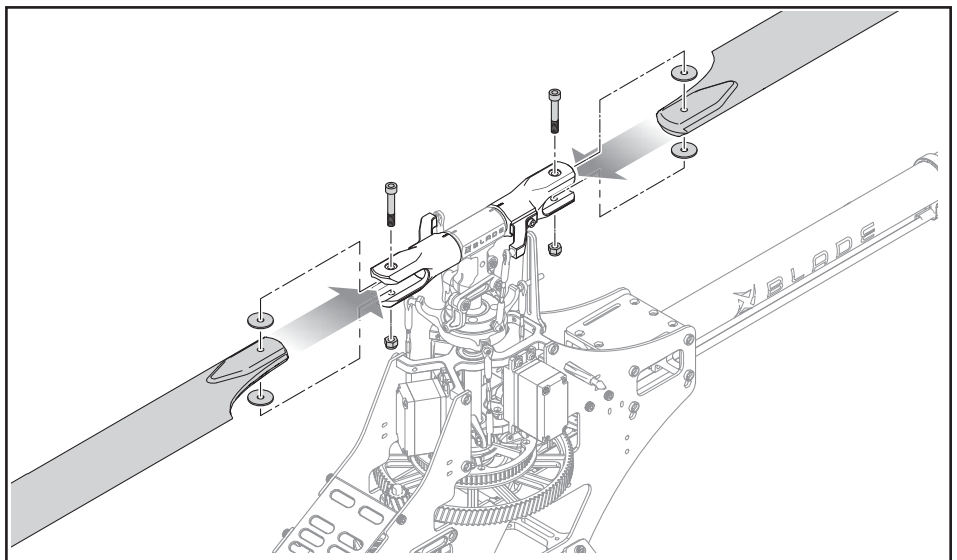

Canopy Installation

1. Install the four canopy grommets into the canopy from the inside.
2. Install the canopy by sliding the canopy grommets over the corresponding canopy posts as shown.

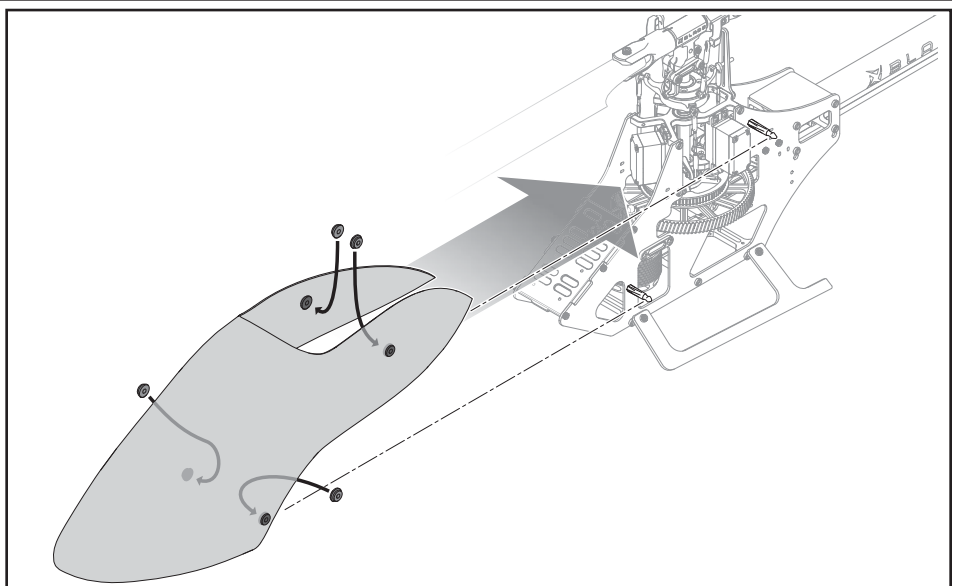

Flight Guidelines and Warnings

- Always keep aircraft in sight and under control.
- Always keep people and pets at least 45 feet (13 meters) away when the battery is connected.
- Keep children out of the vicinity of this product at all times.
- Always turn on throttle hold prior to a rotor strike.
- Always use fully charged batteries.
- Always keep transmitter powered on while the aircraft is powered on.
- Always remove batteries before disassembly.
- Always keep moving parts clean.
- Always keep parts dry.
- Always let parts cool after use before touching.
- Always remove batteries after use.
- Always have a first aid kit with you.
- Always have an appropriate fire extinguisher with you.
- Never operate aircraft with damaged wiring.
- Never touch moving parts.

Flying Your Fusion 480

CAUTION: The Blade Fusion 480 is intended for pilots with experience flying aerobatic, collective pitch helicopters. The Blade Fusion 480 is more responsive than other Blade helicopters. If you are not an experienced 3D or collective pitch helicopter pilot, do not attempt to fly this product.

NOTICE: To minimize damage, always activate throttle hold prior to or during a crash.

WARNING: Only use Blade Fusion 480 approved carbon fiber main blades. Do not use wooden main blades with the Blade Fusion 480. Using wooden main blades may cause injury or property damage.

Consult local laws and ordinances before choosing a location to fly your aircraft.

Select a large, open area away from people and objects. Your first flights should be outdoors in low-wind conditions. Always stay at least 45 feet (13 meters) away from the helicopter when it is flying.

Do not attempt to fly the Blade Fusion 480 indoors.

Blade Tracking

WARNING: Always maintain a safe distance of at least 13 meters (45 feet) when checking the main rotor blade tracking.

WARNING: Always wear protective safety glasses when checking the main rotor blade tracking.

To check the blade tracking:

1. Put the helicopter in a hover at an altitude near eye height.
2. Watch the movement at the blade tips. Both blades should travel in the same plane.
3. If one blade tip appears to be higher than the other, land the helicopter, disconnect the flight battery and adjust the blade linkages.
4. Repeat Steps 1 through 3 until both blades are moving in the same plane.

Post-Flight Inspection and Maintenance

WARNING: Disconnect and remove the flight battery prior to performing any troubleshooting or maintenance. Failure to do so may cause serious injury if the motor starts unexpectedly or if the battery or ESC connections are shorted.

Ball Links	Make sure the plastic ball link holds the control ball, but is not tight (binding) on the ball. When a link is too loose on the ball, it can separate from the ball during flight and cause a crash. Replace worn ball links before they fail.
Cleaning	Make sure the battery is not connected before cleaning. Remove dust and debris with a soft brush or a dry lint-free cloth.
Bearings	Replace bearings when they become notchy (sticky in places when turning) or draggy.
Wiring	Make sure wiring does not block moving parts. Replace damaged wiring and loose connectors.
Fasteners	Make sure there are no loose screws, other fasteners or connectors. Do not over tighten metal screws in plastic parts. Tighten screws so parts are mated together, then turn screw only 1/8th of a turn more.
Rotors	Make sure there is no damage to rotor blades and other parts which move at high speed. Damage to these parts includes cracks, burrs, chips or scratches. Replace damaged parts before flying.
Flight Controller	Make sure the flight controller is securely attached to the frame. Replace the double-sided tape when necessary. The helicopter will crash if the flight controller separates from the helicopter frame.
Gear	Make sure the gears are all in good condition. Watch for chipped teeth or excessive wear. Dust around gears is an indication of excess wear. Replace damaged gears before flying.

Troubleshooting Guide

Problem	Possible Cause	Solution
Helicopter power is lacking	Flight battery has low voltage	Fully charge the flight battery
	Flight battery is old or damaged	Replace the flight battery
	Flight battery cells are unbalanced	Fully charge the flight battery, allowing the charger time to balance the cells
Helicopter will not lift off	Transmitter settings are not correct	Check throttle and pitch curve settings and pitch control direction
	Flight battery has low voltage	Fully charge the flight battery
	Main rotor blades are installed backwards	Install the main rotor blades with the thicker side as the leading edge
The helicopter tail spins out of control	Rudder control and/or sensor direction reversed	Make sure the rudder control and the rudder sensor are operating in the correct direction
	Tail servo is damaged	Check the rudder servo for damage and replace if necessary
	Tail drive gears are damaged	Replace damaged gears.
	Inadequate control arm throw	Check the rudder control arm for adequate travel and adjust if necessary
The helicopter wobbles in flight	Cyclic gain is too high	Decrease gain on the flight controller
	Head speed is too low	Increase the helicopter's head speed via your transmitter settings and/or using a freshly charged flight pack

Limited Warranty

What this Warranty Covers

Horizon Hobby, LLC, (Horizon) warrants to the original purchaser that the product purchased (the "Product") will be free from defects in materials and workmanship at the date of purchase.

What is Not Covered

This warranty is not transferable and does not cover (i) cosmetic damage, (ii) damage due to acts of God, accident, misuse, abuse, negligence, commercial use, or due to improper use, installation, operation or maintenance, (iii) modification of or to any part of the Product, (iv) attempted service by anyone other than a Horizon Hobby authorized service center, (v) Product not purchased from an authorized Horizon dealer, (vi) Product not compliant with applicable technical regulations, or (vii) use that violates any applicable laws, rules, or regulations.

OTHER THAN THE EXPRESS WARRANTY ABOVE, HORIZON MAKES NO OTHER WARRANTY OR REPRESENTATION, AND HEREBY DISCLAIMS ANY AND ALL IMPLIED WARRANTIES, INCLUDING, WITHOUT LIMITATION, THE IMPLIED WARRANTIES OF NON-INFRINGEMENT, MERCHANTABILITY AND FITNESS FOR A PARTICULAR PURPOSE. THE PURCHASER ACKNOWLEDGES THAT THEY ALONE HAVE DETERMINED THAT THE PRODUCT WILL SUITABLY MEET THE REQUIREMENTS OF THE PURCHASER'S INTENDED USE.

Purchaser's Remedy

Horizon's sole obligation and purchaser's sole and exclusive remedy shall be that Horizon will, at its option, either (i) service, or (ii) replace, any Product determined by Horizon to be defective. Horizon reserves the right to inspect any and all Product(s) involved in a warranty claim. Service or replacement decisions are at the sole discretion of Horizon. Proof of purchase is required for all warranty claims. SERVICE OR REPLACEMENT AS PROVIDED UNDER THIS WARRANTY IS THE PURCHASER'S SOLE AND EXCLUSIVE REMEDY.

Limitation of Liability

HORIZON SHALL NOT BE LIABLE FOR SPECIAL, INDIRECT, INCIDENTAL OR CONSEQUENTIAL DAMAGES, LOSS OF PROFITS OR PRODUCTION OR COMMERCIAL LOSS IN ANY WAY, REGARDLESS OF WHETHER SUCH CLAIM IS BASED IN CONTRACT, WARRANTY, TORT, NEGLIGENCE, STRICT LIABILITY OR ANY OTHER THEORY OF LIABILITY, EVEN IF HORIZON HAS BEEN ADVISED OF THE POSSIBILITY OF SUCH DAMAGES. Further, in no event shall the liability of Horizon exceed the individual price of the Product on which liability is asserted. As Horizon has no control over use, setup, final assembly, modification or misuse, no liability shall be assumed nor accepted for any resulting damage or injury. By the act of use, setup or assembly, the user accepts all resulting liability. If you as the purchaser or user are not prepared to accept the liability associated with the use of the Product, purchaser is advised to return the Product immediately in new and unused condition to the place of purchase.

Law

These terms are governed by Illinois law (without regard to conflict of law principals). This warranty gives you specific legal rights, and you may also have other rights which vary from state to state. Horizon reserves the right to change or modify this warranty at any time without notice.

WARRANTY SERVICES

Questions, Assistance, and Services

Your local hobby store and/or place of purchase cannot provide warranty support or service. Once assembly, setup or use of the Product has been started, you must contact your local distributor or Horizon directly. This will enable Horizon to better answer your questions and service you in the event that you may need any assistance. For questions or assistance, please visit our website at www.horizonhobby.com, submit a Product Support Inquiry, or call the toll free telephone number referenced in the Warranty and Service Contact Information section to speak with a Product Support representative.

Inspection or Services

If this Product needs to be inspected or serviced and is compliant in the country you live and use the Product in, please use the Horizon Online Service Request submission process found on our website or call Horizon to obtain a Return Merchandise Authorization (RMA) number. Pack the Product securely using a shipping carton. Please note that original boxes may be included, but are not designed to withstand the rigors of shipping without additional protection. Ship via a carrier that provides tracking and insurance for lost or damaged parcels, as Horizon is not responsible for merchandise until it arrives and is accepted at our facility. An Online Service Request is available at http://www.horizonhobby.com/content/service-center_render-service-center. If you do not have internet access, please contact Horizon Product Support to obtain a RMA number along with instructions for submitting your product for service. When calling Horizon, you will be asked to provide your complete name, street address, email address and phone number where you can be reached during business hours. When sending product into Horizon, please include your RMA number, a list of the included items, and a brief summary of the problem. A copy of your original sales receipt must be included for warranty consideration. Be sure your name, address, and RMA number are clearly written on the outside of the shipping carton.

NOTICE: Do not ship LiPo batteries to Horizon. If you have any issue with a LiPo battery, please contact the appropriate Horizon Product Support office.

Warranty Requirements

For Warranty consideration, you must include your original sales receipt verifying the proof-of-purchase date. Provided warranty conditions have been met, your Product will be serviced or replaced free of charge. Service or replacement decisions are at the sole discretion of Horizon.

Non-Warranty Service

Should your service not be covered by warranty, service will be completed and payment will be required without notification or estimate of the expense unless the expense exceeds 50% of the retail purchase cost. By submitting the item for service you are agreeing to payment of the service without notification. Service estimates are available upon request. You must include this request with your item submitted for service. Non-warranty service estimates will be billed a minimum of ½ hour of labor. In addition you will be billed for return freight. Horizon accepts money orders and cashier's checks, as well as Visa, MasterCard, American Express, and Discover cards. By submitting any item to Horizon for service, you are agreeing to Horizon's Terms and Conditions found on our website http://www.horizonhobby.com/content/service-center_render-service-center.

ATTENTION: Horizon service is limited to Product compliant in the country of use and ownership. If received, a non-compliant Product will not be serviced. Further, the sender will be responsible for arranging return shipment of the un-serviced Product, through a carrier of the sender's choice and at the sender's expense. Horizon will hold non-compliant Product for a period of 60 days from notification, after which it will be discarded.

10/15

Warranty and Service Contact Information

Country of Purchase	Horizon Hobby	Contact Information	Address
United States of America	Horizon Service Center (Repairs and Repair Requests)	servicecenter.horizonhobby.com/RequestForm/	1608 Interstate Drive Champaign, IL 61822
	Horizon Product Support (Product Technical Assistance)	productsupport@horizonhobby.com 877-504-0233	
	Sales	websales@horizonhobby.com 800-338-4639	
European Union	Horizon Technischer Service	service@horizonhobby.eu	Hanskampring 9 D 22885 Barsbüttel, Germany
	Sales: Horizon Hobby GmbH	+49 (0) 4121 2655 100	

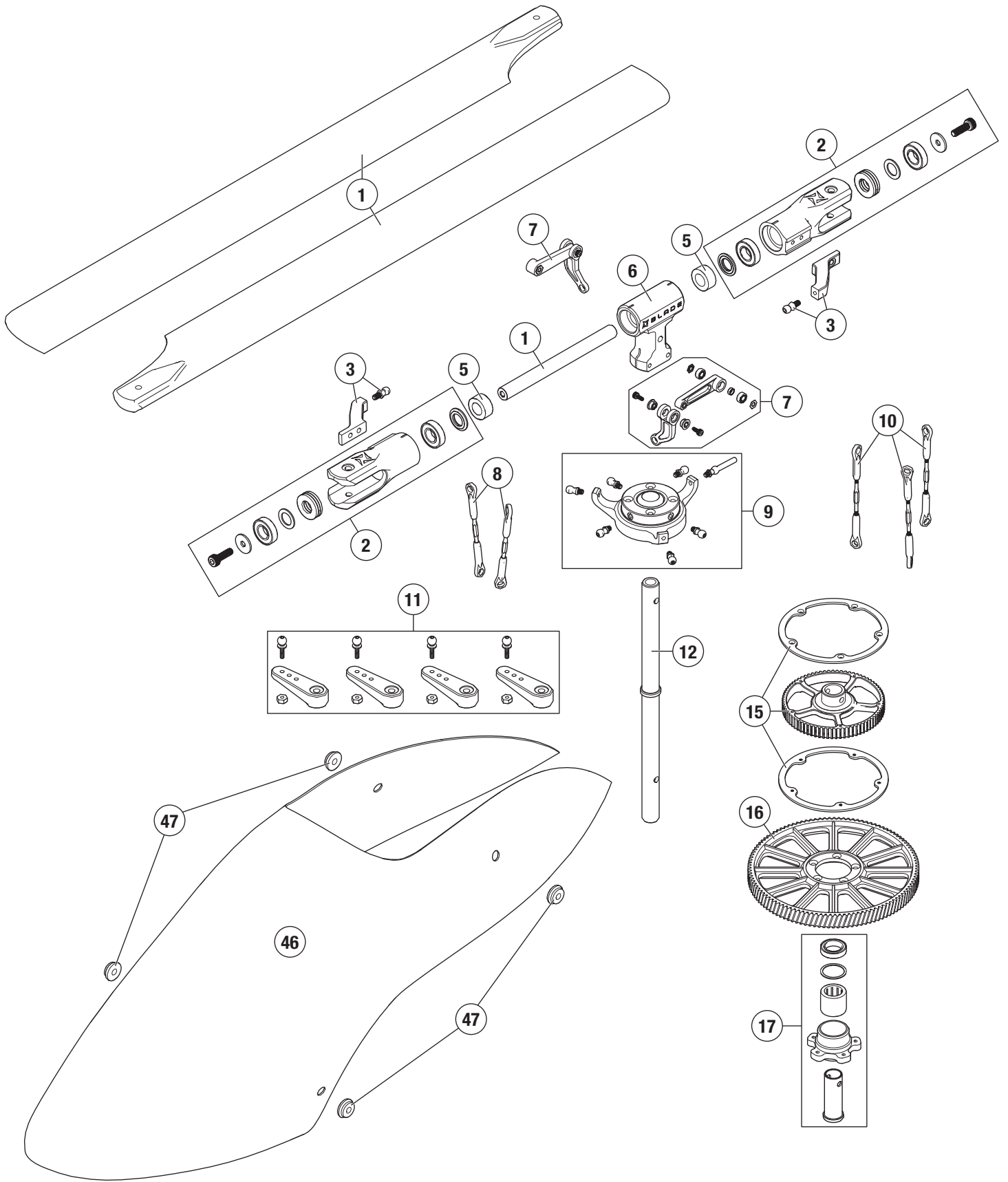

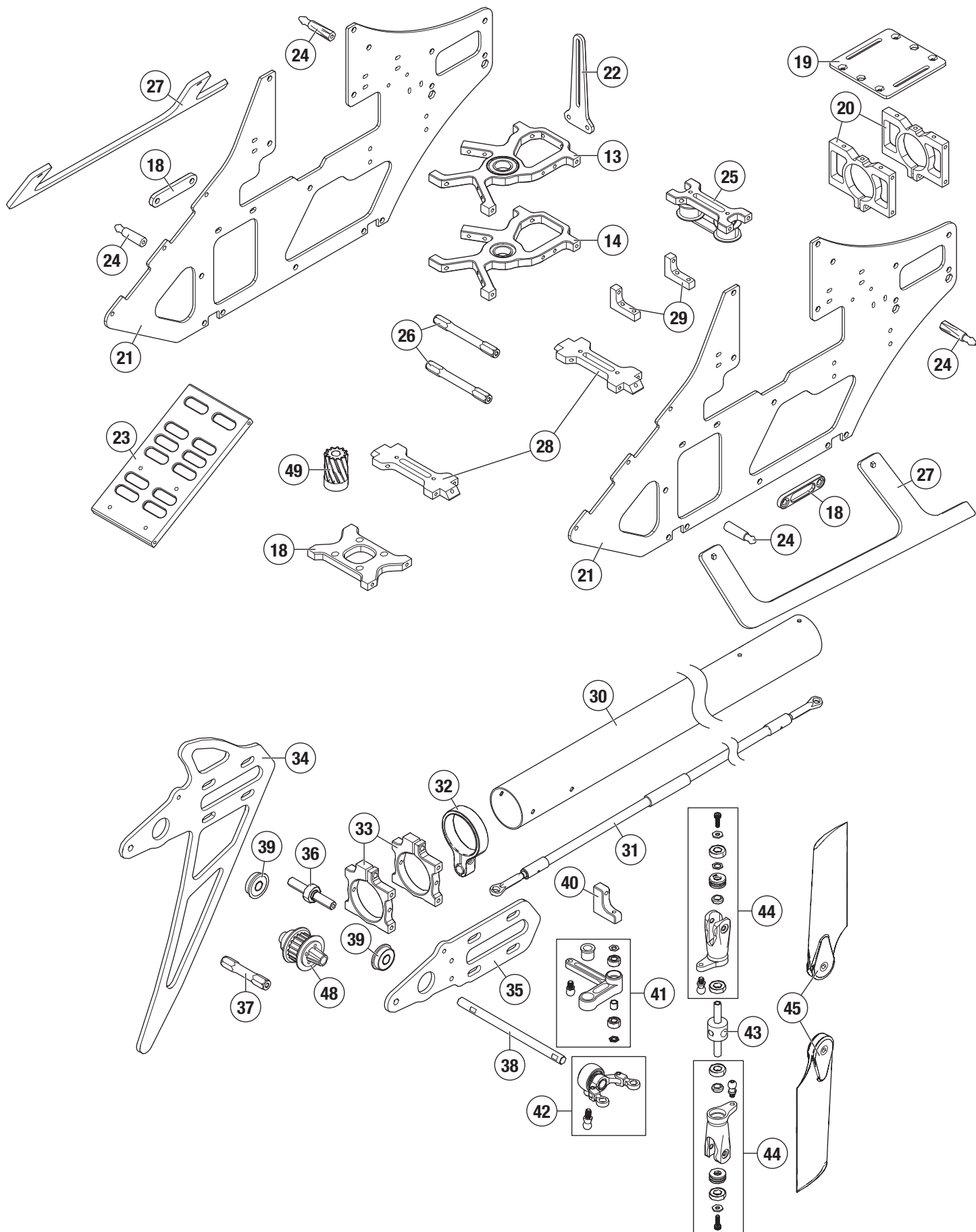

Parts List / Ersatzteile / Pièces de rechange / Pezzi di ricambio

#	Part #	English	Deutsch	Français	Italiano
1	BLH4901	480mm CF Main Rotor Blades (2)	480 mm CF Hauptrotorblätter (2)	Pales du rotor principal 480 mm CF (2)	Pale rotore principale 480 mm CF (2)
2	BLH4902	Main Rotor Grip	Hauptrotorhalter	Poignée du rotor principal	Fermo rotore principale
3	BLH4903	Grip Arm	Halterarm	Poignée	Braccio fermo
4	BLH4904	Spindle	Spindel	Axe	Fuso
5	BLH4905	Dampener Set	Stoßdämpfersatz	Ensemble d'amortisseur	Set ammortizzatori
6	BLH4906	Aluminum Head Block	Aluminium-Kopfblock	Bloc de tête en aluminium	Blocco di testa in alluminio
7	BLH4907	Follower Arm	Folgerarm	Bras suiveur	Braccio elevatore
8	BLH4908	Rotor Head Linkage	Rotorkopf-Verbindung	Tringlerie de tête du rotor	Giunzione di testa del rotore
9	BLH4909	Swashplate Assembly	Taumelscheibenbaugruppe	Ensemble de plateau cyclique	Gruppo piatto ciclico
10	BLH4910	Servo Linkage Set	Servo-Verbindungssatz	Ensemble de tringlerie de servo	Set giunzione servo
11	BLH4911	Servo Arm Set	Servoarm-Satz	Ensemble de bras de servo	Set braccio servo
12	BLH4912	Main shaft	Hauptwelle	Arbre principal	Albero principale
13	BLH4913	Upper Servo Mount	Obere Servohalterung	Support de servo supérieur	Supporto superiore servo
14	BLH4914	Lower Servo Mount	Untere Servohalterung	Support de servo inférieur	Supporto inferiore servo
15	BLH4915	Tail Drive Pulley, 75T	Heckriemenscheibe, 75T	Poulie d'entraînement d'empennage, 75T	Puleggia azionamento coda, 75T
16	BLH4916	Main Gear, 112T	Hauptgetriebe, 112T	Train principal, 112T	Ingranaggio principale, 112T
17	BLH4917	Autorotation Hub	Autorotationsnabe	Moyeu d'autorotation	Mozzo rotazione automatica
18	BLH4919	Motor Mount	Motorhalterung	Support moteur	Supporto motore
19	BLH4921	Gyro Tray	Kreiselhalterung	Plateau de Gyro	Piatto giroscopio
20	BLH4922	Tailboom Mount	Heckauslegerhalterung	Support de poutre de queue	Supporto tubo di coda
21	BLH4923	Main Frame	Hauptrahmen	Châssis principal	Telaio principale
22	BLH4924	Swashplate Guide	Taumelscheibenführung	Guide de plateau cyclique	Guida piatto ciclico
23	BLH4926	Battery Tray	Akkualterung	Support de batterie	Vassoio portabatteria
24	BLH4927	Body Mounts (4)	Gehäusehalterung (4)	Supports de carrosserie (4)	Supporti scocca (4)
25	BLH4928	Tail Belt Front	Heckriemen vorn	Courroie d'empennage avant	Parte anteriore cinghia di coda
26	BLH4929	Frame Spacer (2)	Rahmenabstandshalter (2)	Entretoise de châssis (2)	Distanziatore telaio (2)
	BLH4930	Frame Screw Set (10)	Rahmen-Schraubensatz (10)	Jeu de vis du châssis (10)	Set viti telaio (10)
27	BLH4931	Skid Set (2)	Kufensatz (2)	Ensemble de patin (2)	Set staffa di arresto (2)
28	BLH4932	Skid Mount (2)	Kufenhalterung (2)	Support de patin (2)	Supporto staffa di arresto (2)
29	BLH4933	Tail Servo Mounts	Heckservohalterungen	Support de servo d'empennage	Supporti servo coda
30	BLH4934	Tailboom	Heckausleger	Poutre de queue	Tubo di coda
31	BLH4935	Tailrotor Pushrod	Heckrotorgestänge	Barre de liaison du rotor d'empennage	Asta di comando del rotore di coda
32	BLH4936	T/R Pushrod Guide	Heckrotorgestängeführung	Guide de la barre de liaison du rotor d'empennage	Guida asta di comando T/R
33	BLH4937	Tail Case Mount	Heckgehäusehalterung	Support du boîtier de queue	Supporto contenitore coda
34	BLH4938	Tail Fin	Heckflosse	Aileron caudal	Aletta coda
35	BLH4939	Tail Case	Heckgehäuse	Boîtier de queue	Contenitore coda
36	BLH4940	Tail Belt Guide	Heckriemenführung	Guide de courroie d'empennage	Guida cinghia di coda
37	BLH4941	Tail Case Standoff	Heckgehäuseabstand	Entretoise du boîtier de queue	Staffa contenitore coda
38	BLH4942	Tail Shaft	Heckwelle	Arbre de queue	Albero coda
39	BLH4943	Tail Shaft Bearing	Heckwellenlager	Roulement d'arbre de queue	Cuscinetto albero coda
40	BLH4944	Bell Crank Mount	Winkelhebelhalterung	Support de levier coudé	Supporto biella a campana
41	BLH4945	Tail Bell Crank	Heckwinkelhebel	Levier coudé d'empennage	Biella a campana coda
42	BLH4946	Tail Pitch Slider	Heckschiebehülse	Curseur d'inclinaison arrière	Cursore beccheggio coda
43	BLH4947	Tail Rotor Hub	Heckrotornabe	Moyeu du rotor d'empennage	Mozzo rotore di coda
44	BLH4948	Tail Rotor Grip	Heckrotorhalter	Poignée du rotor d'empennage	Fermo rotore di coda
45	BLH4949	CF Tail Blades	CF Heckblätter	Pales d'empennage CF	Pale coda CF
46	BLH4951	Fiberglass Canopy	Glasfaser-Kanzel	Verrière en fibre de verre	Capottina in vetroresina
47	BLH4952	Canopy Grommets	Kanzelhülsen	Passe-fils de verrière	Guarnizioni capottina
48	BLH4954	Tail Pulley	Umlenktrummel	Poulie d'empennage	Puleggia coda
49	BLH4958	11t Pinon	11T Ritzel	Pignon 11t	Pignone 11t
	BLH4961	Tail Belt	Heckriemen	Courroie d'empennage	Cinghia di trasmissione coda

Recommended Components / Empfohlene Komponenten / Composants recommandés / Componenti raccomandati

Part #	English	Deutsch	Français	Italiano
BLH4953	Brushless Motor 4320-1300kV	Bürstenloser Motor 4320-1300 kV	Moteur sans balais 4320-1 300 kV	Motore brushless 4320-1300 kV
CSE010009700	Talon 90 Heli ESC 010-0097-00	Talon 90 Hubschrauber-Geschwindigkeitsregler 010-0097-00	Variateur ESC Talon 90 Heli 010-0097-00	Talon 90 elicottero ESC 010-0097-00
EFLB44006S30	4400mAh 6S 22.2V 30C LiPo, 10AWG EC5	4400 mA 6S 22,2 V 30C LiPo, 10 AWG EC5	4 400 mAh 6S 22,2 V 30 C Li-Po, 10 AWG EC5	4400 mAh 6S 22,2V 30C LiPo, 10AWG EC5 (EFLB44006S30)
SPMAR7210BX	AR7210BX DSMX FBL Control Sys	AR7210BX DSMX FBL-Steuersystem	Système de commande AR7210BX DSMX FBL	Sistema di controllo AR7210BX DSMX FBL
SPMSH6050	H6050 H-T M-S Heli Cyclic Servo	H6050 H-T M-S Hubschrauber-Steuerservo	Servo cyclique H6050 H-T M-S Heli	Servo ciclico H6050 H-T M-S elicottero
SPMSH6060	H6060 M-T U-S Heli Tail Servo	H6060 M-T M-S Hubschrauber-Heckservo	Servo d'empennage H6060 M-T U-S Heli	Servo coda H6060 M-T U-S elicottero

Optional Parts / Optionale Bauteile / Pièces optionnelles / Pezzi opzionali

Part #	English	Deutsch	Français	Italiano
KXSB40006S40	F-Tek 4000mAh 6S 40C, EC5, LED	F-Tek 4000 mA 6S 40C, EC5, LED	F-Tek 4 000 mAh 6S 40 C, EC5, LED	F-Tek 4000mAh 6S 40C, EC5, LED
BLH4918	12t Pinon: Fusion 480	12T Ritzel: Fusion 480	Pignon 12t : Fusion 480	Pignone 12t: Fusion 480
BLH4920	BLS Motor: 4020-1350Kv	Bürstenloser Motor: 4020-1350 kV	Moteur sans balais : 4020-1 350 Kv	Motore brushless: 4020-1350Kv
BLH4962	11t Pinion 5mm Shaft: Fusion 480	11T Ritzel 5 mm Welle: Fusion 480	Arbre de 5 mm du Pignon 11t : Fusion 480	Pignone 11t Albero 5 mm: Fusion 480
SPMSH6050	H6050 H-T M-S Heli Cyclic Servo	H6050 H-T M-S Hubschrauber-Steuerservo	Servo cyclique H6050 H-T M-S Heli	Servo ciclico H6050 H-T M-S elicottero
SPMSH6060	H6060 M-T U-S Heli Tail Servo	H6060 M-T M-S Hubschrauber-Heckservo	Servo d'empennage H6060 M-T U-S Heli	Servo coda H6060 M-T U-S elicottero
SPMSH6350	H6350 U-T / H-S Heli Cyclic Ser	H6350 U-T/H-S Hubschrauber-Steuerservo	Servo cyclique H6350 U-T / H-S Heli	Servo ciclico H6350 U-T / H-S elicottero
SPMSH6360	H6360 M-T / U-S Heli Tail Servo	H6060 M-T/U-S Hubschrauber-Heckservo	Servo d'empennage H6360 M-T / U-S Heli	Servo coda H6360 M-T U-S elicottero



©2018 Horizon Hobby, LLC.
Blade, the Blade logo, EC5, DSM, DSM2, DSMX and the Horizon Hobby logo
are trademarks or registered trademarks of Horizon Hobby, LLC.
The Spektrum trademark is used with permission of Bachmann Industries, Inc.
Created 5/18

50111

BLH4925