

**SNAP CIRCUITS**  
ELENCO

# myHome

Simply Snap Together!

**Your Home  
Your Power  
Know How It Works**

**Projects  
1 - 34**

**Find out**  
How electricity works  
in your home.

**Ages 8 to 108**

Three (3) "AA" batteries not included



**ELENCO**  
Learn by doing.

MADE WITH **CIRCUITS SAFE**  
FUSE TECHNOLOGY

Copyright © 2020 Elenco® Electronics, Inc. All rights reserved. No Part of this book shall be reproduced by any means; electronic, photocopying, or otherwise without written permission from publisher. U.S. Patents 7,144,255; 7,273,377; Patents Pending

753062



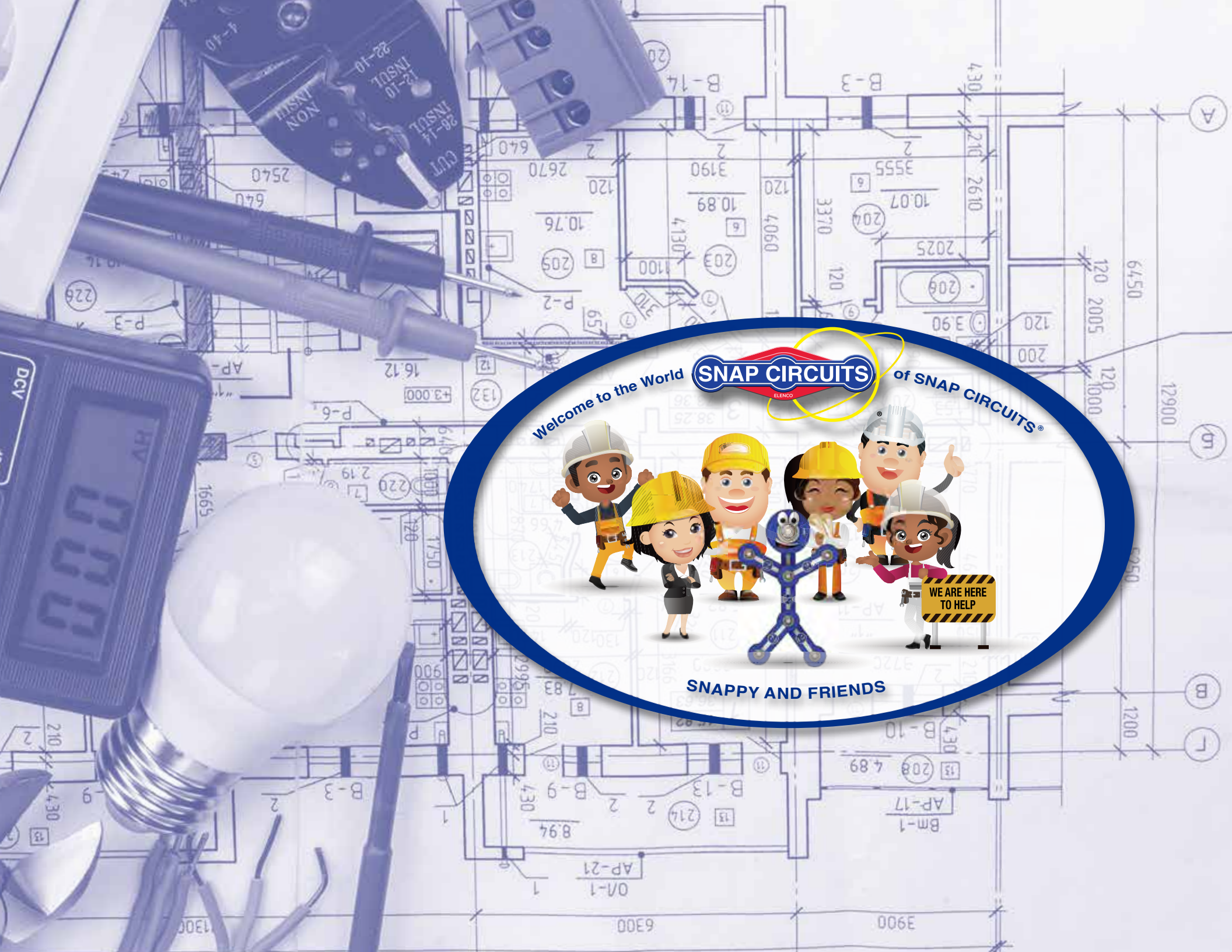

Welcome to the World



of SNAP CIRCUITS®



SNAPPY AND FRIENDS



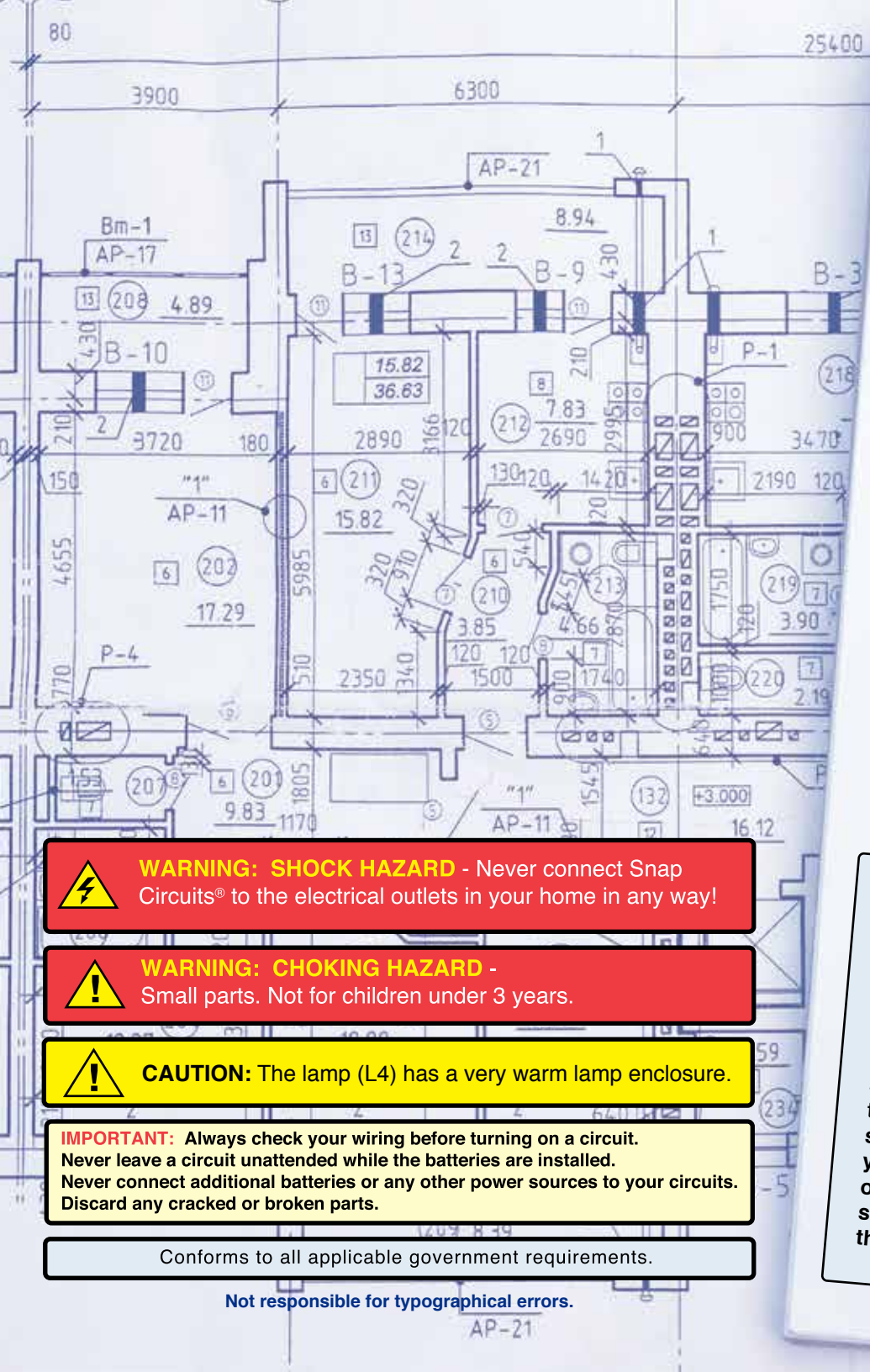

# 🏠 Table of Contents

INTRODUCTION TO ELECTRICITY	3-6
ELECTRICITY IN OUR WORLD	7-8
AS ELECTRICITY ENTERS YOUR HOME	9-11
Project Listings	12
Projects 1 - 34	13-50
How To Use Your Snap Circuits®	51-53
Parts List	54
About Your Snap Circuits® Parts	55-57
DO's and DON'Ts of Building Circuits	58
Troubleshooting	59-60
Notes	61
SC- MyH7 Parts Layout	62

**⚡ WARNING: SHOCK HAZARD** - Never connect Snap Circuits® to the electrical outlets in your home in any way!

**⚠ WARNING: CHOKING HAZARD** - Small parts. Not for children under 3 years.

**⚠ CAUTION:** The lamp (L4) has a very warm lamp enclosure.

**IMPORTANT:** Always check your wiring before turning on a circuit. Never leave a circuit unattended while the batteries are installed. Never connect additional batteries or any other power sources to your circuits. Discard any cracked or broken parts.

Conforms to all applicable government requirements.

Not responsible for typographical errors.

**A Note to Parents and Adults:**

Because children's abilities vary so much, even with age groups, adults should exercise discretion as to which experiments are suitable and safe (the instructions should enable supervising adults to establish the experiment's suitability for the child). Make sure your child reads and follows all of the relevant instructions and safety procedures, and keeps them at hand for reference.

This product is intended for use by adults and children who have attained sufficient maturity to read and follow directions and warnings.

Never modify your parts, as doing so may disable important safety features in them, and could put your child at risk of injury.

# INTRODUCTION TO ELECTRICITY



How do you turn on your light or your television or anything else that requires power in your home<sup>1</sup>? You flip a switch, right? And if the switch doesn't work, what do you do?

*You check to see if it's plugged in.*

Anything that requires power (or charging) in your home must be 'plugged in' to the wiring inside the walls of your house or your building. The wiring inside your house is connected to the power cables on your street. And the power cables on your street are connected to the power lines that travel through your community and, eventually, back to the power plant.



**Nobody really knows what electricity is.**

We just know that it is associated with the movement of subatomic charged particles called **electrons** . Just as water is made up of bazillions of tiny water droplets , electricity is made up of bazillions of tiny **electrons**.

**These electrons flow through metal wires the same way water flows through pipes.**

You may have seen how **water wheels** use flowing water or a waterfall to power machines, right? Well, devices like motors, speakers, and light bulbs use flowing electrons to do things like move cars, play music,

and make light. The water that comes out of your faucets has to come from somewhere. That water is pumped through pipes from your city's water storage facilities or, if you live in the country, from your well outside. In the same way, the electricity in your house or building is pumped through wires or cables from your city's power stations. That electricity has to come from somewhere too.

**Your world is powered by electricity.**

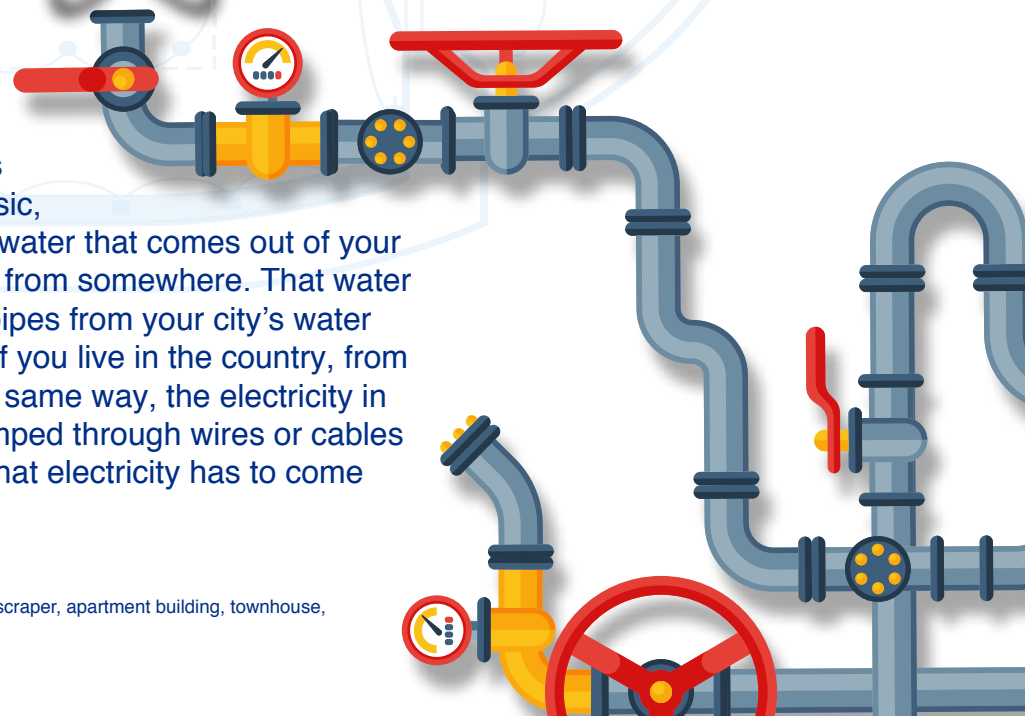
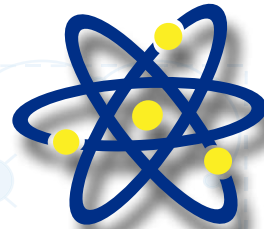
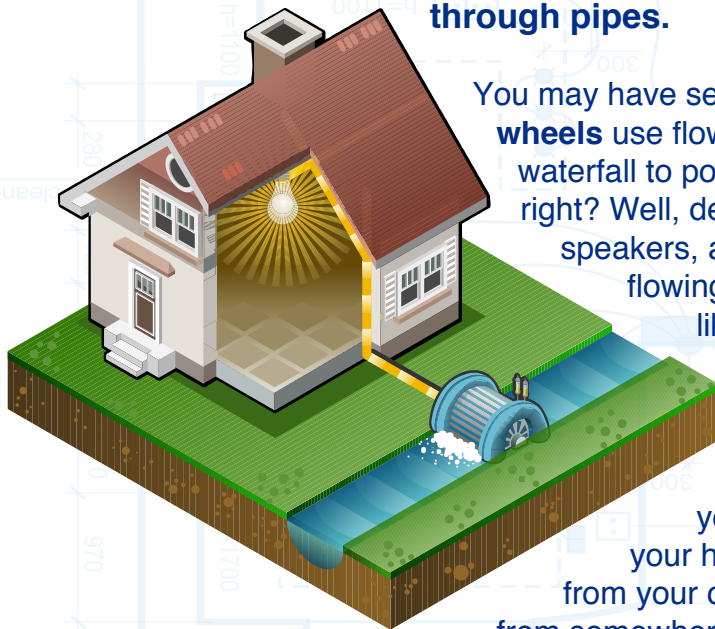

<sup>1</sup>In this manual, sometimes we say "house" or "building" or "home". Whether you live in a city skyscraper, apartment building, townhouse, or farmhouse in the country - it doesn't matter - electricity works the same way!



**Valves and faucets** control the flow of water throughout your home and into appliances like your **washing machine** and refrigerator.



Switches and transistors control the flow of electricity throughout your home and into appliances like lamps and fans. Turning a switch off blocks the passage of electricity the way that turning a faucet off blocks the passage of water.



Like **water**, electricity must flow in one direction in order to do its work. It has to get from the power station to your house, and on to the next house and the buildings thereafter. The power station only pumps electricity in one direction, so you have no choice in the matter.

You just plug into a power outlet, and you're ready to go. It's not so easy with portable power sources like **batteries**. Fortunately, batteries have (+) and (-) signs to show you which direction they pump their electricity. This is why you have to put your battery in 'the right way', taking care that the (+) side of the battery is in the (+) side of the battery holder, in order for it to work.

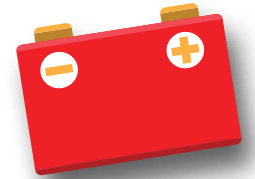

The amount of pressure (or push) a pump puts on the water inside a pipe is measured in **PSI (pounds per square inch)**. The amount of pressure a battery (or other power source) puts on the electrons inside a wire is measured in V (volts) and is called the **voltage**.

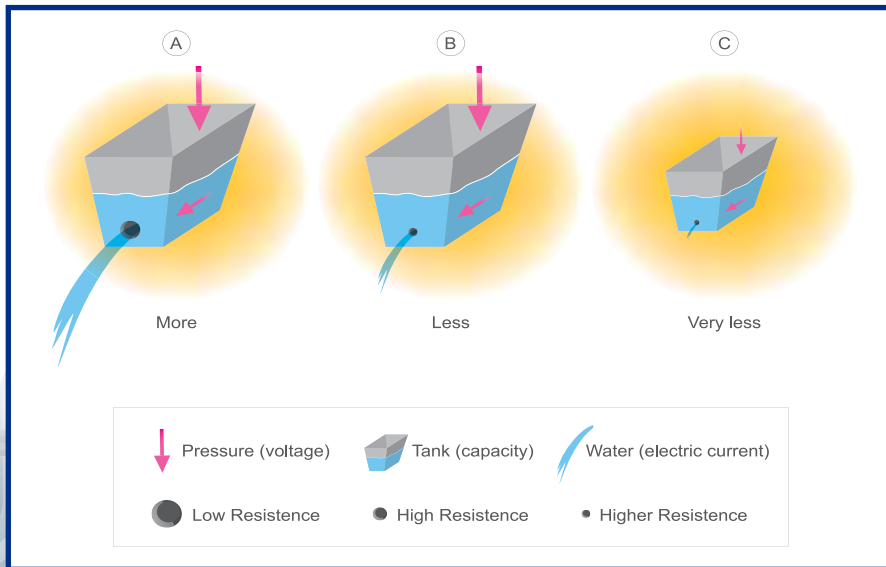

The speed that water flows in the ocean or through a pipe is called its current.

**Electrical current** (measured in amperes (A) or milliamps (mA, 1/1000 of an ampere)) is the speed that electricity flows through a wire. In either case, the faster the speed, the higher the current. Any electric current measurements you make with this set will be in milliamps.







The **power** provided by a battery (or other power source) is the amount of work that its stream of electricity can do at any given moment. **A harder stream of water will get more dirt off your car, right? This is because a hard stream of water has more power than a weak stream. Batteries that produce harder streams of electrons have more power too.** And just as the power of an ocean wave is a combination of its size and speed, the power of an electrical source is a combination of its voltage and the current it can provide. The mathematical relationship is **Power = Voltage x Current**, and power is measured in **W or watts**.

In order to flow, electricity needs a complete circuit of conducting wire.

This means it **must** have a continuous wire pathway from the (+) side of the battery (or power station) to the (-) side of the battery (or power station). We can place components (like a light bulb, motor, or appliance) in the path of the electricity and they will slow the electricity down, but they will not stop it. Only a break in the main transmission line (called a circuit breaker) can do that.

The **resistance** of an electrical component or circuit indicates how much it **resists** the electrical pressure (voltage) by blocking the flow of electrons. The larger the blockage in a clogged pipe, the more slowly water flows through it, right? In the same way, electricity flows more slowly through components with higher resistances (measured in ohms,  $\Omega$ ). Sometimes we place special components called **resistors** in a wire pathway for the sole purpose of slowing down the electrons flowing through it.

The current, voltage, and resistance of an electrical system are all related to one another through this simple mathematical equation:

$$\text{Voltage} = \text{Current} \times \text{Resistance.}$$

This equation is very important in electronics.

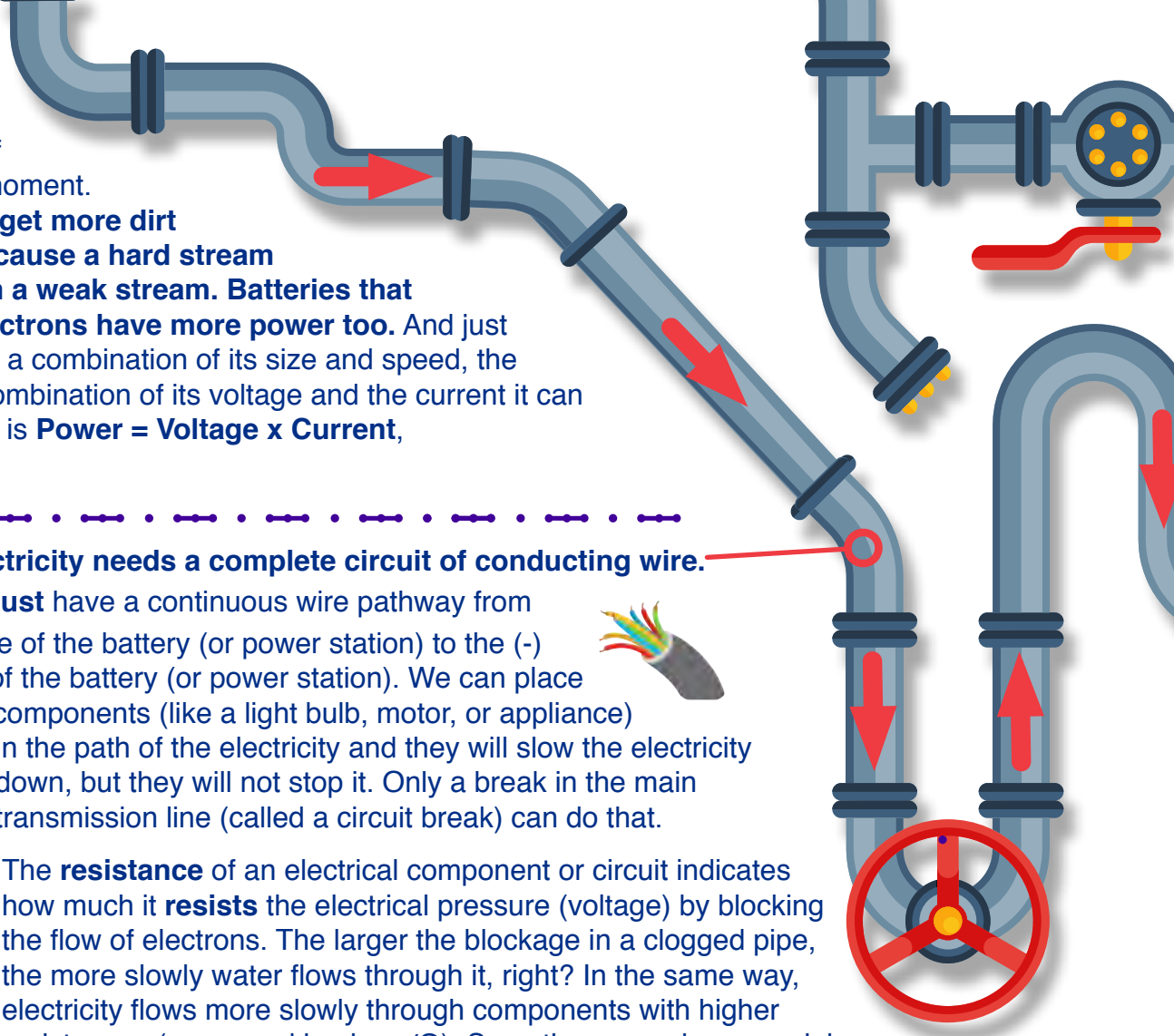









# ELECTRICITY IN OUR WORLD

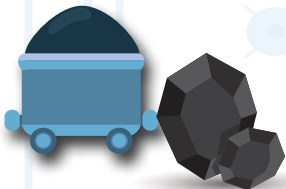

A small amount of the electricity we use comes from the chemical energy in batteries (like the **AA batteries** in your B3 battery holder), but **most of the electricity used in our world is produced at enormous generators driven by steam or water pressure, or (increasingly) by wind or solar.**





**Fossil fuels (coal/oil/natural gas) or nuclear fuels** are burned/consumed to produce high-pressure steam that drives electric generators. Dams create high water pressure that drives electric generators.

**Windmills use wind to drive electric generators.**

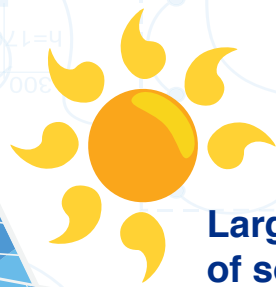

**Large arrays of solar cells produce electricity.**



**Wires are used to efficiently transport this energy to homes and businesses where it is used.** Once there, motors inside our appliances (the ones that are plugged in and turned on) turn that electricity back into the mechanical motion required to make these appliances work. The most important aspect of electricity in our society - more important than the benefits of the Internet - is that it allows energy to be easily transported over distances.

**Transformer**



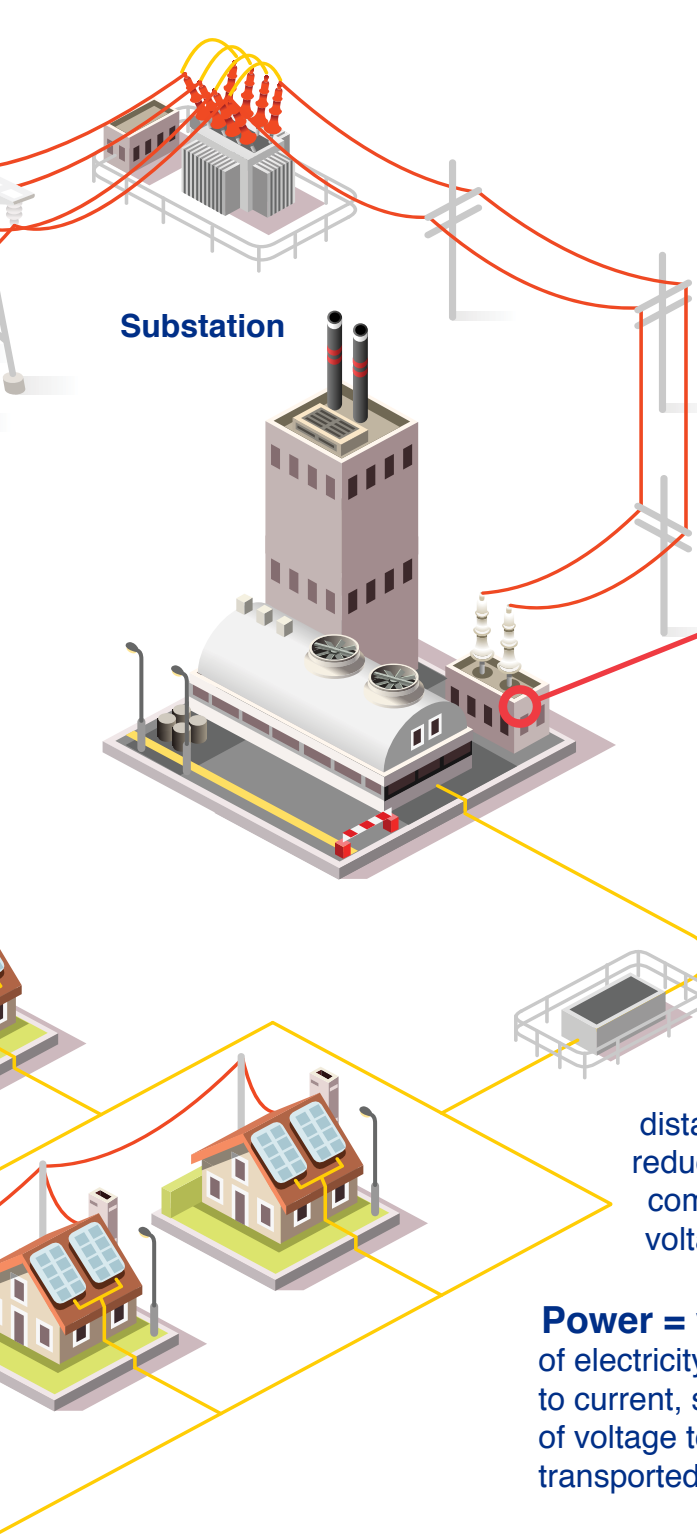

Note that “distances” includes not just large distances but also tiny distances.

Try to imagine a plumbing structure of the same complexity as the circuitry inside a portable radio - it would have to be large because we can't make water pipes so small.

Electricity allows complex designs to be made very small.

**Most electricity produced at large generating stations comes out at very high voltage (sometimes >100,000V).**

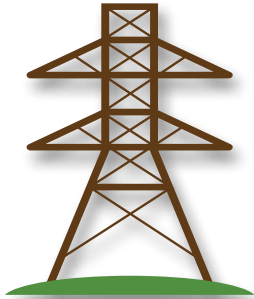

This electricity goes through high-voltage transmission lines poles that stretch across the country.

When it reaches a **substation**, **transformers** reduce the voltage so it can be sent on smaller power lines. It travels through distribution lines to your neighborhood. Smaller transformers reduce the voltage again to the 120V used in our homes.

Electricity is transported over long distances at high voltage because this reduces the amount lost in transmission, compared to transporting it at lower voltage.

**Power = voltage x current**, and the amount of electricity lost in transmission is proportional to current, so transformers change the ratio of voltage to current to allow electricity to be transported more effectively over long distances.

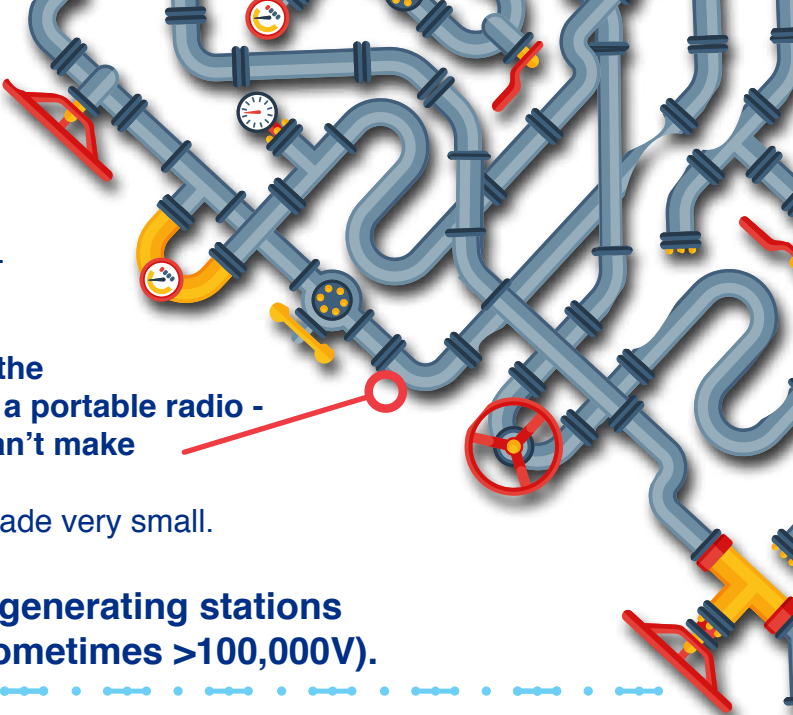

Projects 1-2 will show how electricity can generate motion in a motor, and projects 5-6 will show how motion in a motor can be used to produce electricity.

This concept may not seem important to you but it is actually the foundation of our present society's power.

# AS ELECTRICITY ENTERS YOUR HOME

Before it goes into your house or building, the electricity produced at the power station goes through a meter and is measured by your electric company to determine how much you are using (and how much it will cost you).



The electricity then goes through a service panel (usually in the basement or garage), where fuses or circuit breakers protect the wires inside your home from being **overloaded**.

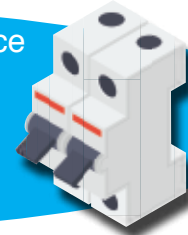

Fuses are designed to shut down a circuit when the current **gets too high**. This can happen when a person uses an appliance the wrong way, or when the appliance is designed badly or just malfunctions. When a high current spike passes through a fuse, it causes the fuse to break. With the fuse broken, the metal pathway into your house is also broken (disconnected), so that electricity can no longer flow. This shutdown prevents further damage to the circuit and can prevent explosions or fires. Fuses are important for safety and most electrical products have one.

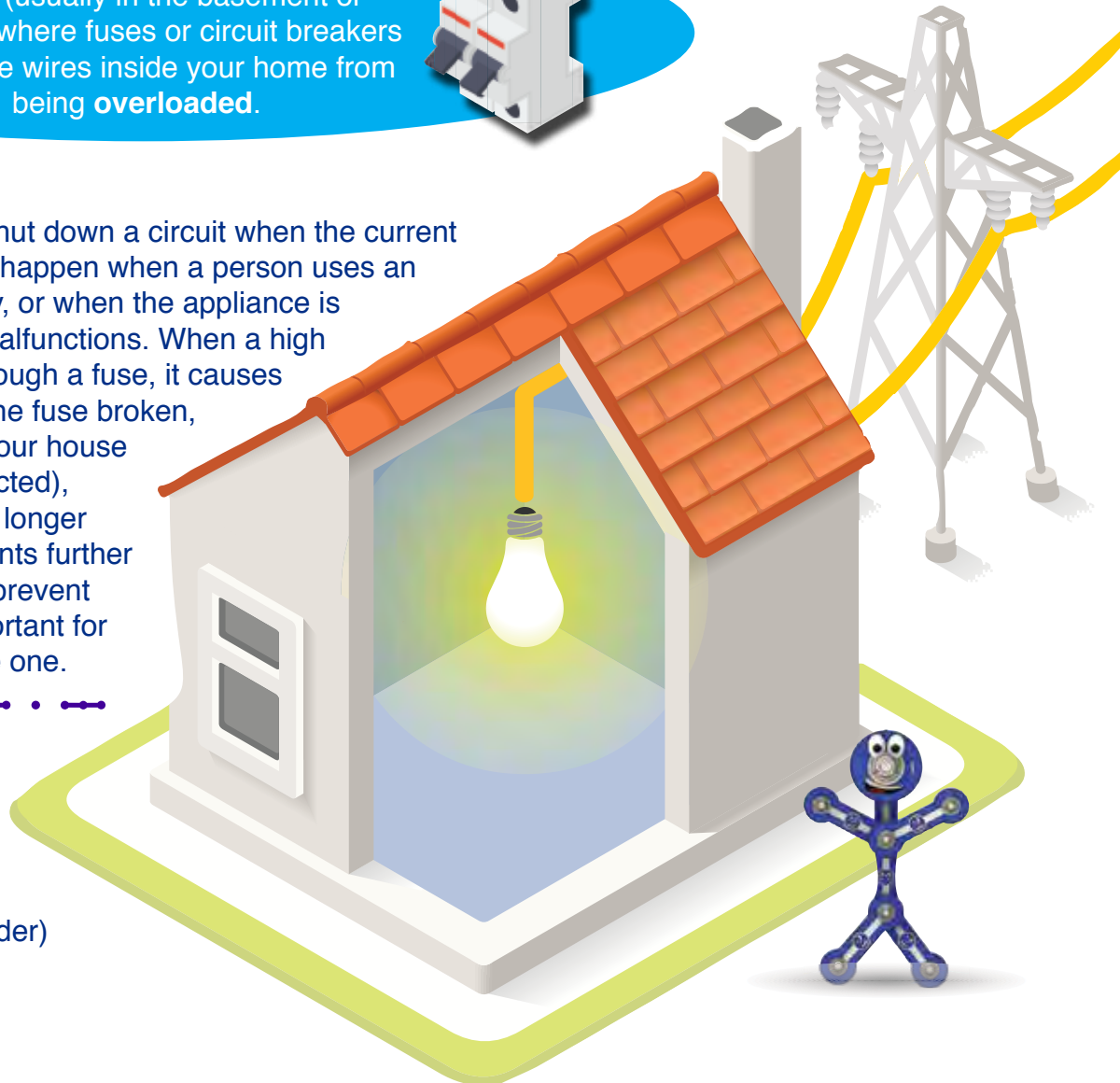

Some fuses need to be replaced after they “blow”, but others can be reset by flipping a **switch**, and some (like the one in your B3 battery holder) can reset automatically.



**Fuses in your home's fuse box are designed to prevent a problem in part of your house from starting a fire or affecting the rest of your house.**

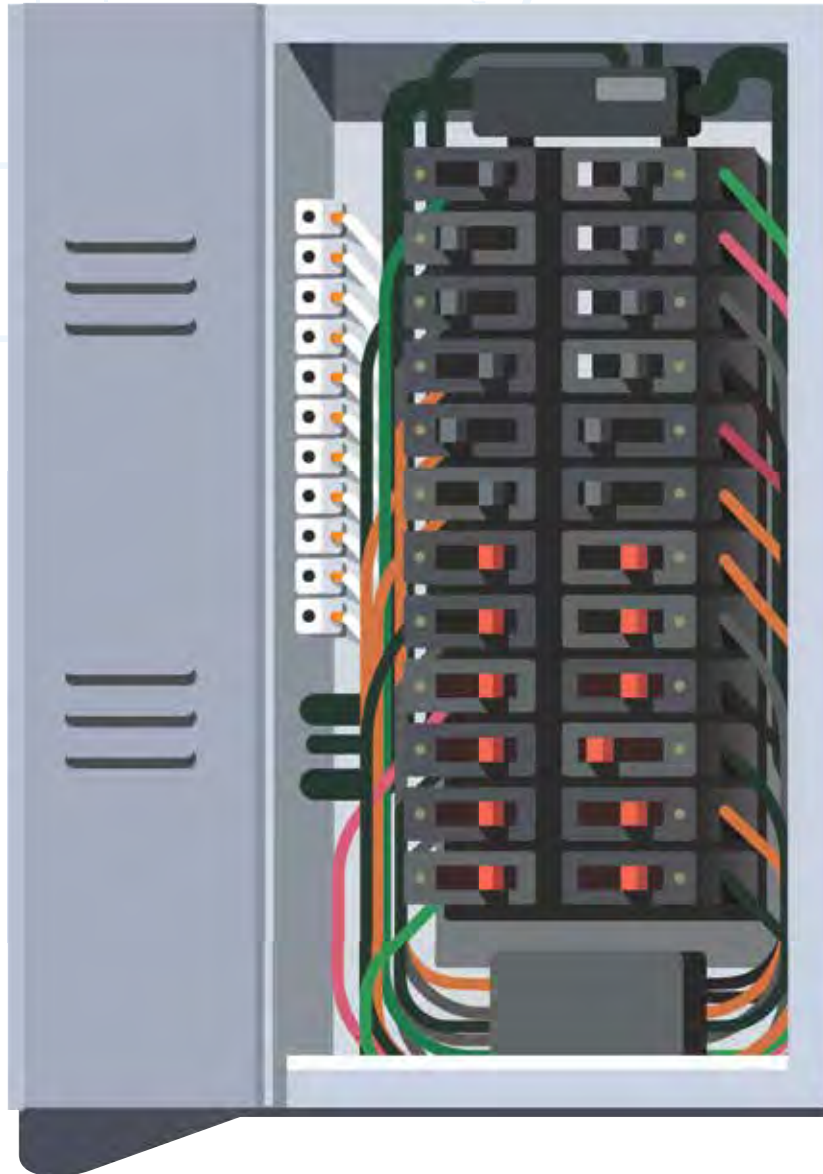

But **fuses** are not designed to protect you directly from getting hurt when you use an electrical appliance in your home because the normal operating power of some appliances is already enough to be dangerous to people.

If lightning hits a transmission line or electrical cable entering your house, it can cause a massive spike of electricity to suddenly pass through the cable and into your home.



So much electricity in such a short space of time can **overload your appliances**, burning out their components or electrical connections, which can cause a fire.

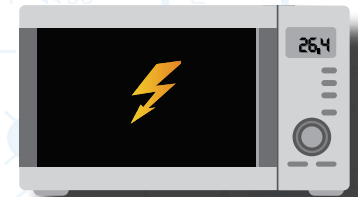

Fortunately, the wires enter your home through a **service panel**, where **fuses and circuit breakers** will block this high-powered electricity from damaging your home and your family.

(Learn more about lightning in Project 34)

# AS ELECTRICITY ENTERS YOUR HOME

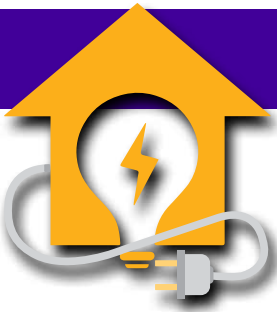

**When lightning (or ice or wind) causes a tree to fall and break a power line**, a gap is created in the line that cuts off electricity to every building along its route. If it is a main transmission line, entire towns and cities can lose power until the line is repaired.

When this happens, it's no use plugging your appliances in and turning them on, the electricity is 'out'. This is when batteries come in handy; and your phone, your car, your video-game controller wouldn't be the same without them.

After successfully passing through the fuses or circuit breakers in your service panel, the electricity travels through wires inside your walls to outlets and switches all over your house. The electrical wiring in **your house** is hidden by plaster and wooden walls, ceilings, and floors and requires a lot of work to install and access when repairs are needed.

Use your electrical appliances according to their instructions in order to ensure the electricity in your house works the way it's intended.

*It's your home and your power, you should know how it works to keep your gadgets going and to stay safe!*

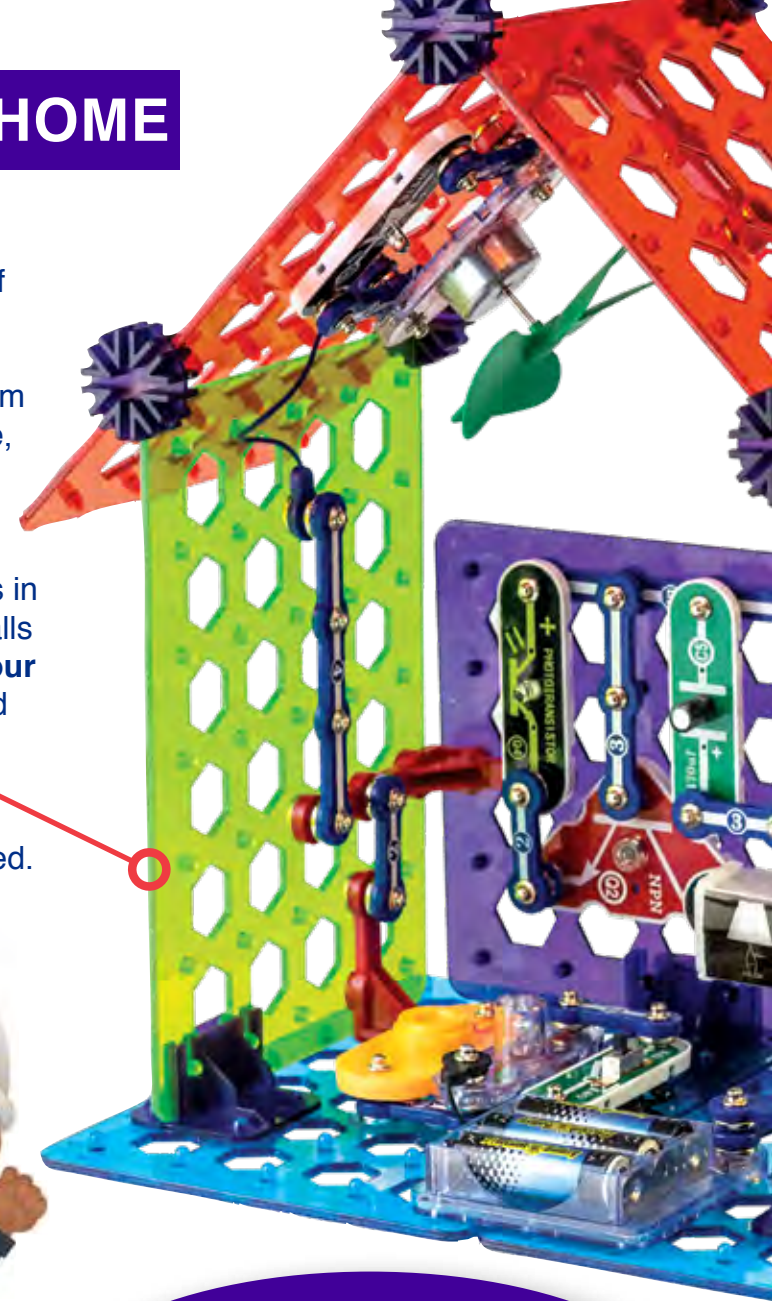

**Thank you**  
to children's author Melissa Rooney, PhD,  
for her assistance in writing the Introduction  
and other sections of this manual.  
You can find out more about Melissa at  
[www.melissarooneywriting.com](http://www.melissarooneywriting.com).



# PROJECT LISTINGS



Project	Description	Page	Project	Description	Page
1	Meet Your Parts	13-14	18	Electric Heater	35
2	Wire Up! Lights Can Share The Same Circuit	15	19	Water Completes Circuit	35
3	Dependent Lights	16	20	Automatic Light	36
4	Independent Lights	17	21	Tree Lighting	36
5	Windmill	17	22	Transistor Amplifier	37
6	Mini-Windmill	18	23	Light & Sound	37
7	Overhead Lights	19-20	24	Audio Fan Speed Adjuster	38
8	Electric Home	21-24	25	Distance Loss Simulator	38
9	Home Security	25-26	26	Light-Controlled Light	39
10	Block the Sound	27	27	Photo Control	39
11	Materials Tester	28	28	Infrared-Controlled Light	40
12	Dim Color Light	28	29	IR Control	40
13	Mini Battery	29	30	2-Story House	41-42
14	Storing Electricity	30	31	3-Wall House	43-44
15	Fader	32	32	High Ceiling House	45-46
16	Timed Wall of Fun	32	33	2-Story Building	47-48
17	Festive House	33-34	34	Static Electricity	49-50

Projects 1-2 demonstrate your parts in simple circuits.  
 Projects 3-4 demonstrate simple circuit arrangements.  
 Projects 5-6 demonstrate using a motor as a generator.  
 Project 7 is a simple 3D circuit construction.  
 Project 8 demonstrates and explains what electricity does in a home.  
 Projects 9-29 are basic circuits and applications.  
 Projects 30-33 are large 3D home circuits.  
 Project 34 demonstrates static electricity.



# Project 1 | MEET YOUR PARTS

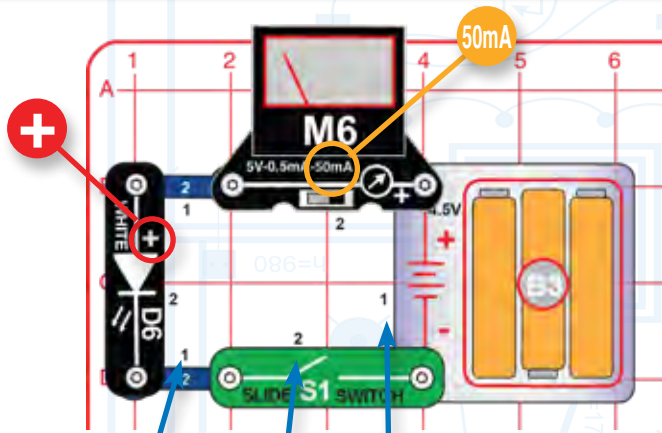

Placement Level Numbers

Build the circuit shown on the left by placing all the parts with a black 1 next to them on the base grid first. Then, assemble parts marked with a 2. Install three (3) "AA" batteries (not included) into the battery holder (B3) if you have not done so already. Set the meter (M6) to the 50mA setting.

Turn on the slide switch (S1). The white LED (D6) lights and the meter measures the current.

Snap Circuits® uses electronic blocks that snap onto a clear plastic base grid to build different circuits. These blocks have different colors and numbers so you can easily identify them. This set contains five different color base grids, you may use any one to build the circuit.



The circuits in this book often do not use a resistor or other component to slow down the electrical current passing through the LED. Normally this would damage an LED, because LEDs can only handle very low currents (much smaller than the current provided by your battery). But your Snap Circuits® LEDs have resistors built into them, and these internal resistors protect the LEDs by slowing down the current. Be careful if you use electrical sets with unprotected LEDs, as you will need to use external resistors to prevent them from burning out.

## WHAT IS REALLY HAPPENING HERE ?

1. The batteries (B3) convert chemical energy into electrical energy and "push" it through the circuit, just like the electricity from your power company. A battery pushes electricity through a circuit like a pump (or gravity in the case of a water tower) pushes water through pipes.
2. The snap wires (the blue pieces) carry the electricity around the circuit, just like wires carry electricity around your home. Wires carry electricity like pipes carry water.
3. The meter (M6) measures how much electricity flows in a circuit, like a water meter measures how fast water flows in a pipe.
4. The white LED (D6) converts electrical energy into light, it is similar to a lamp in your home except smaller. LEDs are increasingly being used for home lighting because they are more efficient than other types of bulbs. An LED uses the energy carried by electricity, resisting its flow like a pile of rocks resists the flow of water in a pipe.

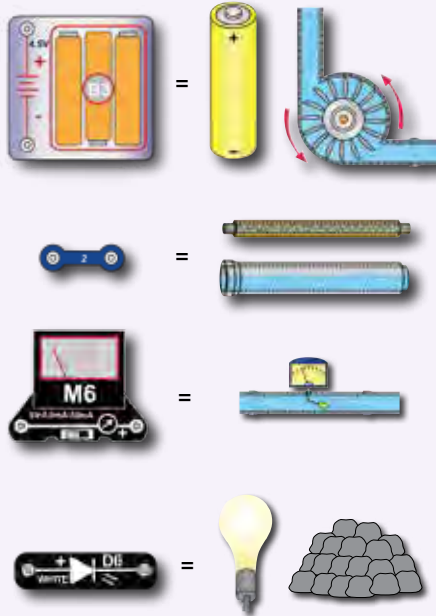

5. The slide switch (S1) controls the electricity by turning it on or off, just like a light switch on the wall of your home. A switch controls electricity like a faucet controls water.

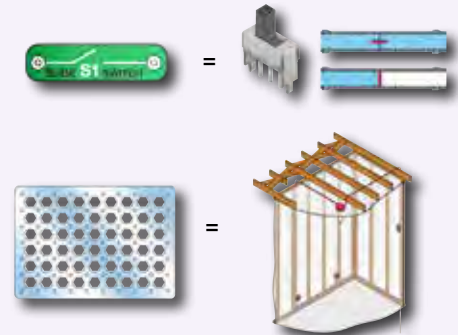

6. The base grid is a platform for mounting the circuit, just like how wires are mounted in the walls of your home to control the lights.

### Comparing Electric Flow to Water Flow:

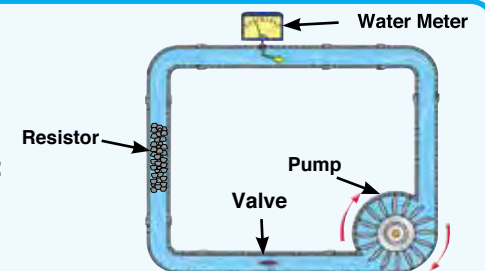



**Part B:** Replace the white LED with the color LED (D8, "+" on top) and enjoy the light show as the meter measures the current. For best effects, dim the room lights.

**Part C:** Replace the color LED with the lamp (L4). The current measured on the meter will be very high and off the scale (you are measuring a 200mA lamp with a 50mA meter). Incandescent light bulbs are much less energy efficient than LEDs. *Do not leave the circuit for two minutes because the lamp will be hot.*

**Part D:** Replace the lamp with the melody IC (U32, "+" on top) and listen to the sound as the meter measures the current.

**Part E:** Replace the melody IC with the motor (M4) and green fan and see the fan spin as the meter measures the current. Reverse the orientation of the motor to make the fan spin in the opposite direction (this changes whether the fan blows air up or down).

**Part F:** Replace the motor with the phototransistor (Q4, "+" on top) and vary the amount of light shining on it. The current measured on the meter varies from near zero when you cover the phototransistor to high when you shine a flashlight directly on it.

**Part G:** Replace the phototransistor with the 5.1kΩ resistor (R3) and see the current on the meter. The current will be very low, but you can change the meter to the 0.5mA setting to confirm that some current is flowing.

LEDs are light emitting diodes, which convert electrical energy into light. The color of light from an LED depends on the characteristics of the material used in it. The color LED actually contains separate red, green, and blue lights, with a micro-circuit controlling them.



The lamp (L4) converts electricity into light. It is an incandescent light bulb, just like other incandescent bulbs in homes except smaller. In an incandescent bulb electricity heats up a high-resistance wire until it glows, producing light. Incandescent light bulbs are very inefficient, converting less than 5% of the electricity used into light, with the rest becoming heat. LEDs are much more efficient than incandescent light bulbs, and are increasingly being used for home lighting and flashlights.



The melody IC makes an electrical pattern from tunes recorded in its memory. A speaker inside it then converts the electrical pattern into sound by making mechanical vibrations. These vibrations create variations in air pressure which travel across the room. You "hear" when your ears feel these air pressure variations.



The motor uses magnetism to convert electricity into mechanical motion (see page 57 [About Your Parts] for more explanation).



The phototransistor is a material whose electrical resistance varies depending on the amount of light shining on it.



A resistor "resists" or slows down the flow of electricity. Resistors are used to limit or control electricity in a circuit.



To learn more go to pages 55-57.



# Project 2 | WIRE UP! LIGHTS CAN SHARE THE SAME CIRCUIT

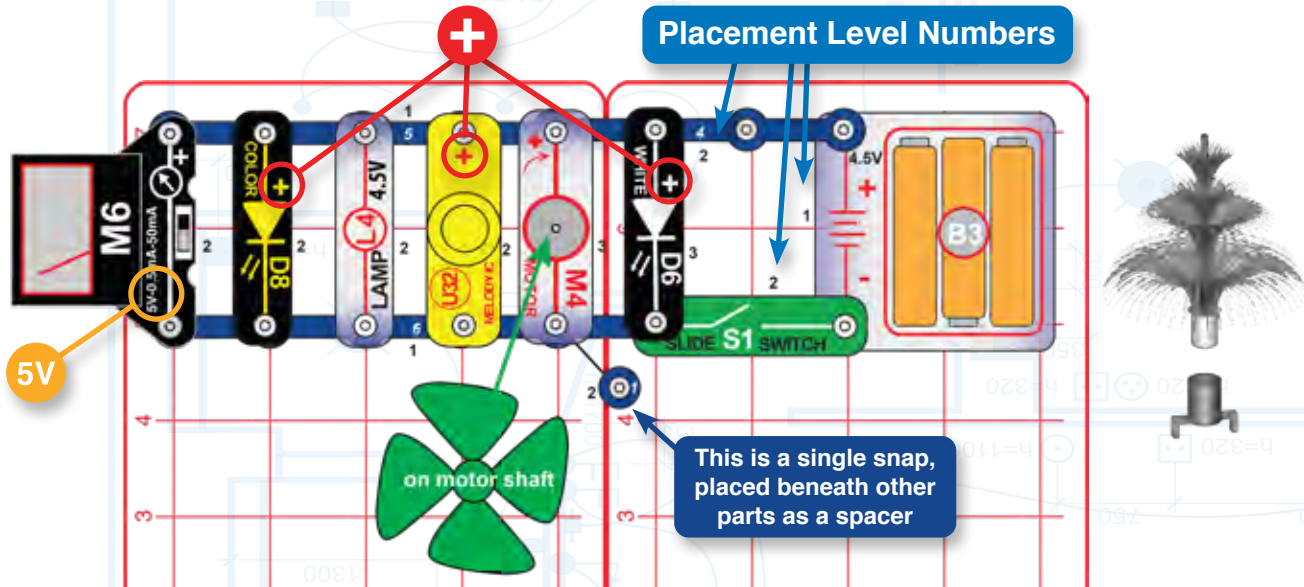

Build the circuit shown. Set the meter (M6) to the 5V setting. If desired, place the fiber optic festive tree in its mounting base and on the color LED (D8). Turn on the slide switch (S1) and enjoy the show.

The meter measures the voltage from the batteries - this may be 4.5V if your batteries are new, but will likely be less because the circuit components are a heavy load on the batteries. Try removing the lamp, motor, melody IC, and LEDs, one at a time and see how the measured voltage changes. *Do not leave the circuit for two minutes because the lamp will be hot.*

The battery voltage (electrical pressure) may drop as the current increases, because the batteries may not be able to supply all the current the circuit needs. This effect is more noticeable when the batteries are weaker. The lamp needs much more current than the other components, so it has the greatest effect on the battery voltage.

A "brownout" occurs when power plants cannot supply enough current to a city during high demand, and must reduce the voltage they supply. This sometimes occurs on hot days in summer when everyone is using their air conditioners.

**Note:** base grid colors are interchangeable, so use any color you like.





# Project 3 | DEPENDENT LIGHTS

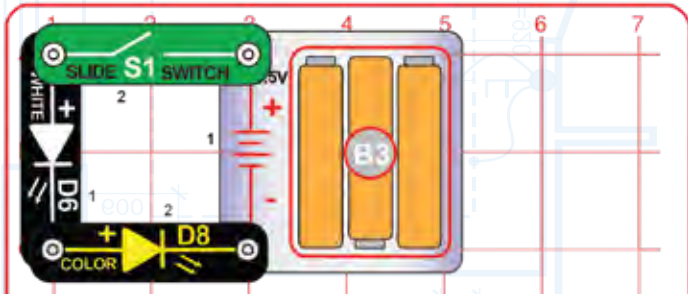

Build the circuit and turn on the slide switch (S1). The white and color LEDs (D6 & D8) should be blinking but may be dim. If neither lights at all then replace your batteries.

The two LEDs are connected in a series, and all the electric current from the batteries flows through each component in the circuit. The LEDs are dim because the voltage from the batteries (B3) is divided between them.

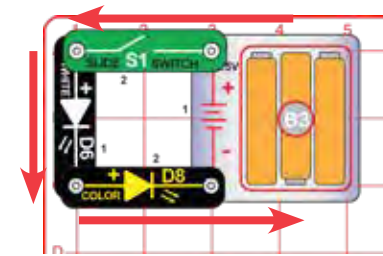

Connecting parts in series is one way of arranging them in a circuit. The advantage of it is that wiring them together is simple. The disadvantage is that if one LED breaks, all will be off.



This circuit has both LEDs connected in **SERIES**. Series circuits are simple to connect, and allow one component to easily control another (here the white LED blinking is controlled by the color LED's blinking). The LEDs may be dim because the battery voltage may not be high enough to make both bright. **If one LED breaks, then the circuit is broken and neither will work.**

The slide switch (S1) is also connected in series with the LEDs, so it can turn them on and off.



# Project 4 | INDEPENDENT LIGHTS

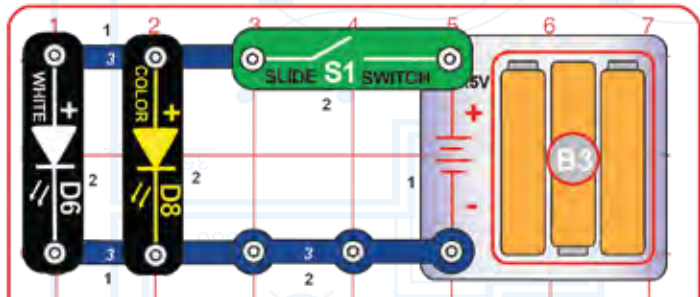

Build the circuit and turn on the slide switch (S1). The white and color LEDs (D6 & D8) are bright now and only the color LED is blinking.



Compare this circuit to the preceding circuit. This circuit has both LEDs connected in PARALLEL. Parallel circuits make components independent of each other but require more complex wiring (notice how this circuit requires more parts than the preceding circuit). Both LEDs are bright because each gets the full battery voltage, but they will drain the batteries faster. If one LED breaks then the other will still work.

In this circuit the batteries produce an electric current, which flows through the switch, then divides between the 2 LEDs, then re-combines and flows back into the batteries.

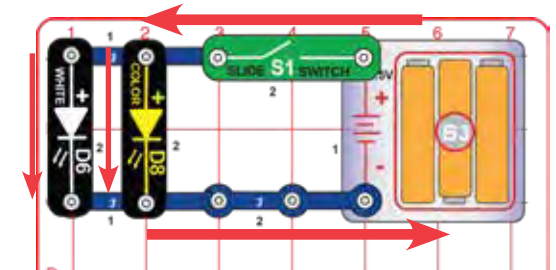

The two LEDs are connected in parallel with one another. They are bright because each LED gets the full battery voltage. Most of the lights in your house are connected in parallel; so if one bulb burns out then the others are not affected.

# Project 5 | WINDMILL

## Assembly:

1. Place base grid supports on base grid B.
2. Place parts on grid A, and install into base grid supports on grid B.
3. Install remaining parts on grid B.

Set the meter to the 50mA scale and blow on the fan to simulate a strong wind. You can also set the meter to the 5V scale to measure the voltage produced.

Replace the meter with the color LED ("+" on left). If you blow hard enough then the color LED (D8) will light.



Here the clear motor (M4) is a generator that uses the physical motion of the windmill to pump electricity through the circuit. The motors in commercial windmills are much more efficient, meaning they generate less heat and waste less electricity. Windmills also use fan blade shapes and materials that lower friction (friction is how hard the wind has to push on the blades to make them move), so they can produce electricity even in light winds.

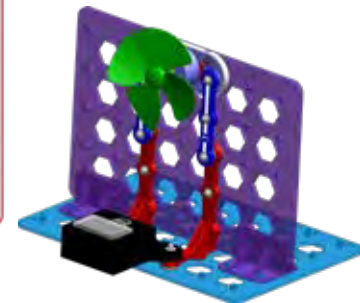
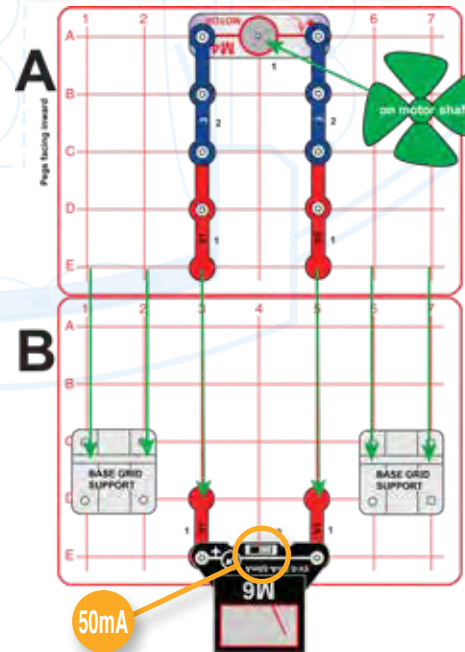



# Project 6 | MINI-WINDMILL

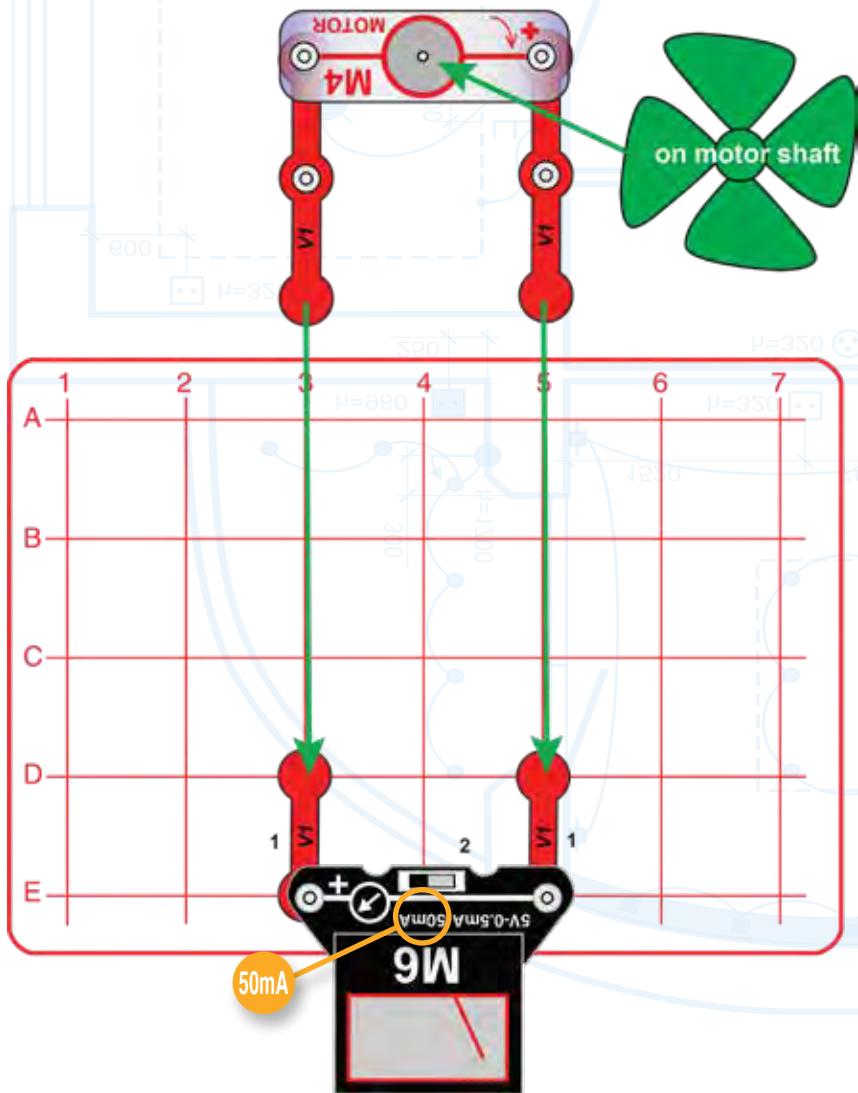

Change the preceding circuit into this one. Now blow on the fan to simulate wind. If you blow hard enough, the color LED (D8) lights up. Is it easier to light the LED in this circuit or the previous circuit?

This circuit improves the air flow by removing the base grid from behind the fan, but it is not as physically stable and comes apart more easily.



If you want to save energy, set your thermostat so your home is a little cooler in the winter and a little warmer in the summer. Every extra degree of heating or cooling reduces your energy cost significantly. You can use a programmed timer to automatically reduce heating or cooling when you know you will be away from home or asleep.

# Project 7 | OVERHEAD LIGHTS

Think of this circuit as a room with an overhead light. Electricity flows from the batteries on the floor to the white LED on the ceiling, down to the slide switch on the other wall, and then back to the batteries. The batteries represent the power supplied by your local electric company. The white LED is a ceiling light. The slide switch is the switch on your wall that turns the ceiling light on or off. And the blue snap wires are the wires in the walls of your house. The colored base grids are just the structure of your house.



**Note:** Base grid colors are interchangeable, so use any color you like at any location.

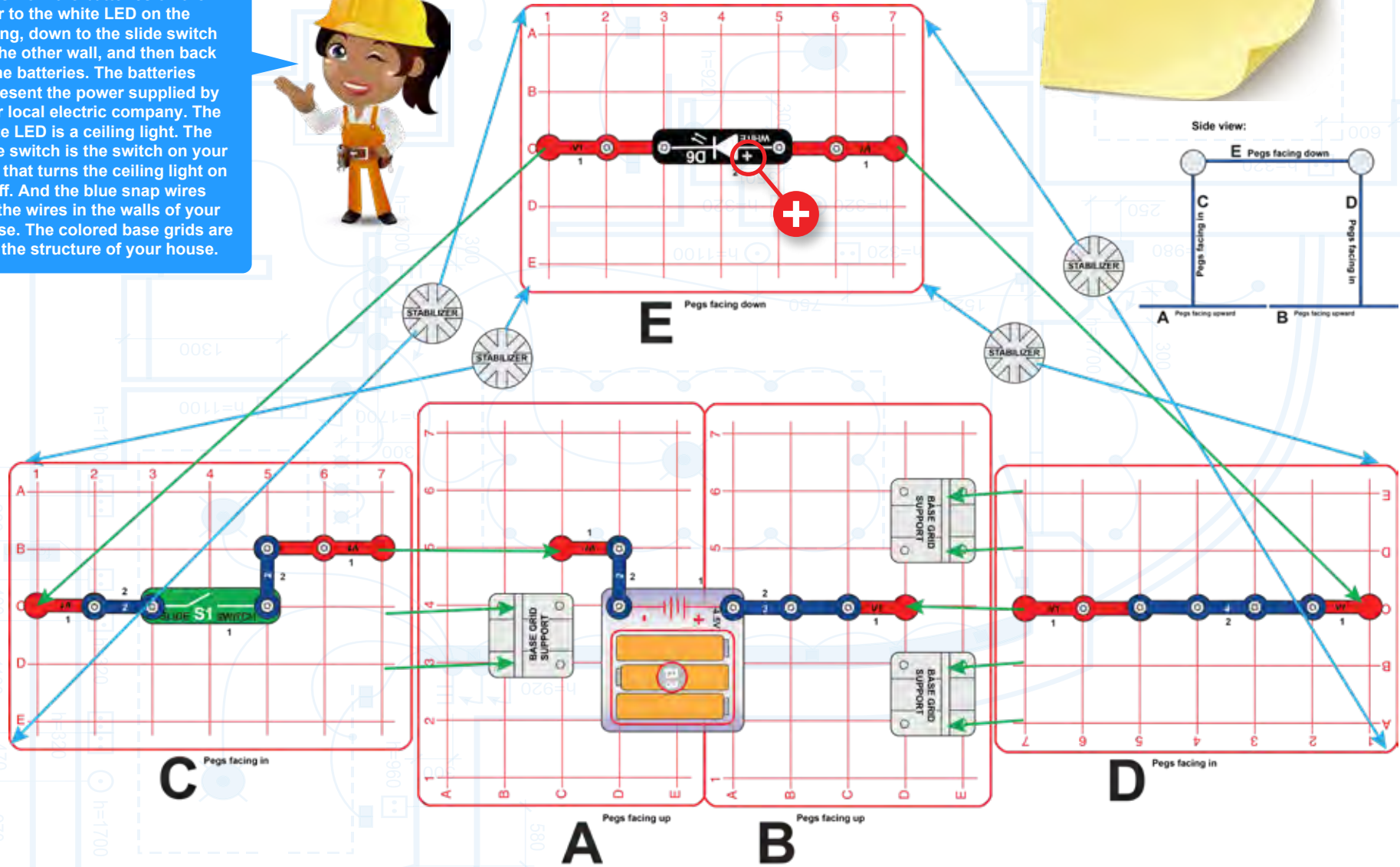



**Assembly (adult supervision recommended):**

1. Place base grid supports on base grids A & B.
2. Place parts on base grids C, & D, and install into base grid supports on grids A & B. The pegs should be facing inward. Base grid colors are interchangeable, so you any color you like at any location.

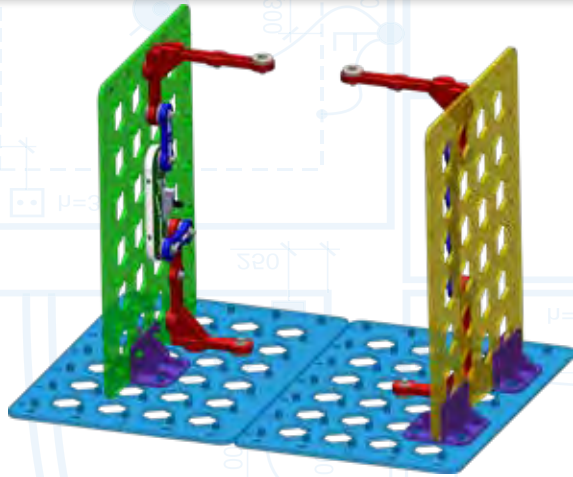

3. Mount grid E on top of grids C & D using 4 stabilizers, attaching the 2 vertical snap wires (V1) as you do it.

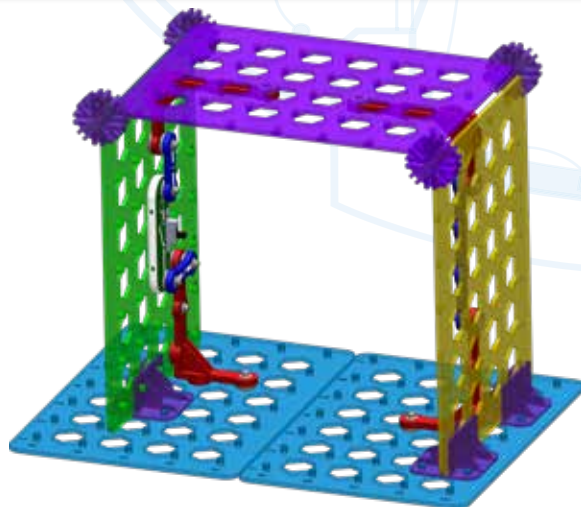

4. Place the remaining parts on grids A, B, & E.  
Turn on the slide switch (S1) to light the white LED (D6).

Go to [www.elenco.com/products/myhome](http://www.elenco.com/products/myhome) for an interactive 3D picture to help with constructing this circuit.

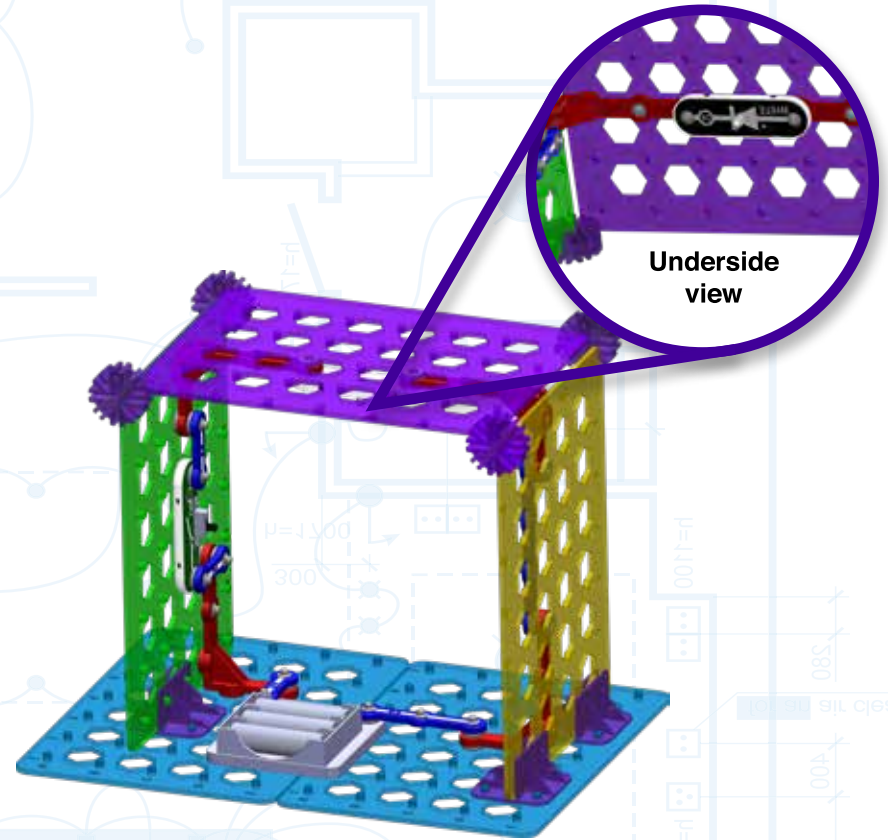

**Part B:** Carefully replace the white LED (D6) with the color LED (D8), or carefully add the color LED next to the white LED as shown here.

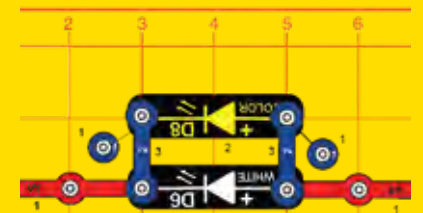



# Project 8 | ELECTRIC HOME

The light covers and slides may be placed on the LEDs (D6 and D8) or lamp (L4) as decoration. Fold the slides as indicated and slide them into the slots on the cover, as shown.



Front-Side view:  
Stabilizers are identified as F1-F4 and B1-B4 (Front 1-4 and Back 1-4), as shown on this drawing.

Side view:

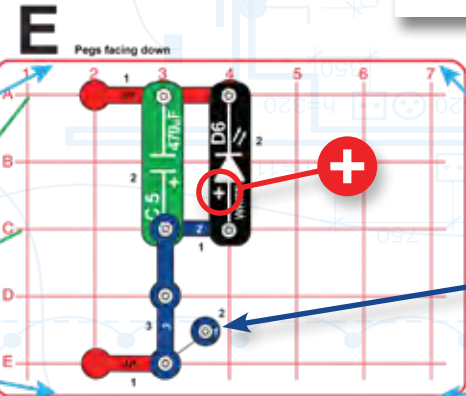
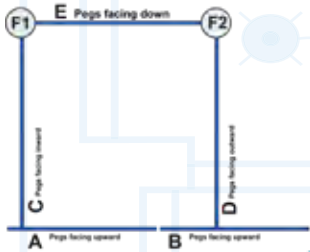

This is a single snap, placed beneath other parts as a spacer

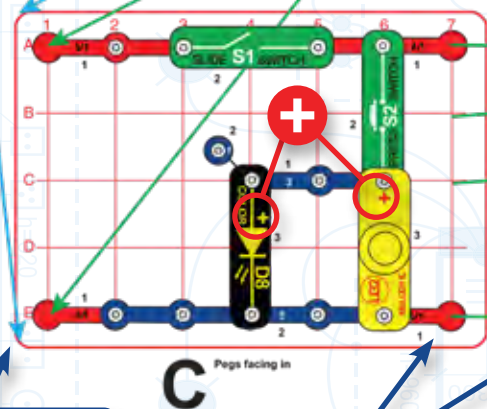

The grids fit into the supports easier if the column marking (1-7) is on this side.

These red pieces are the same vertical snap wire (V1), mounted so it stands up.

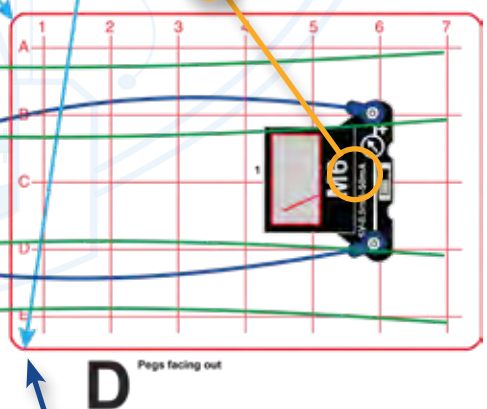
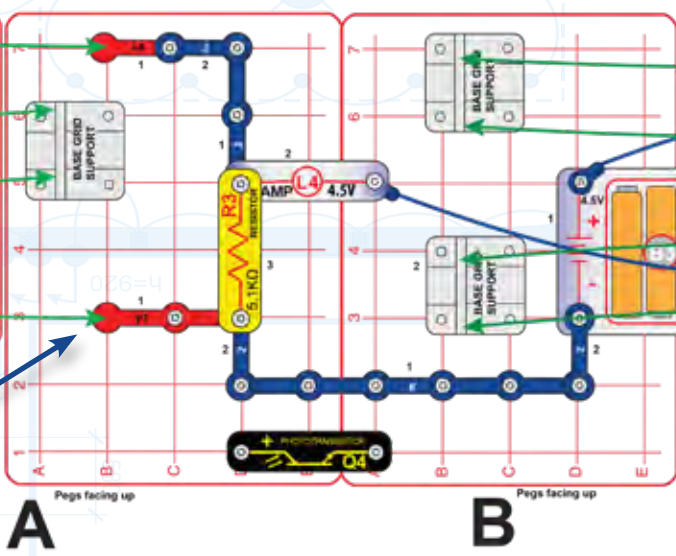

The grids fit into the supports easier if the column marking (1-7) is on this side.



### Assembly (adult supervision recommended):

1. Place base grid supports on base grids A & B.
2. Place parts (except the blue jumper wires) on base grids C & D, and install into base grid supports on grids A & B. The pegs should be facing inward on grid C and outward on grid D. Base grid colors are interchangeable, so you can use any color you like at any location.

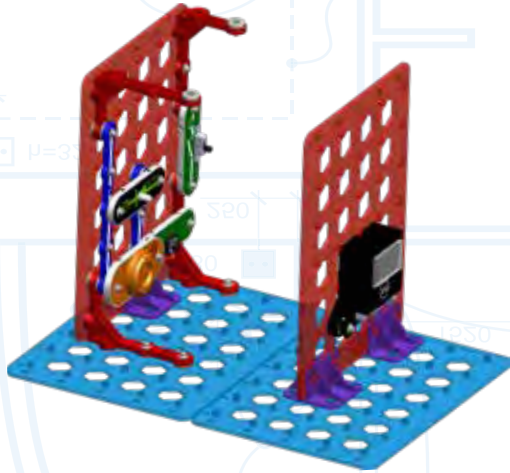

3. Mount grid E on top of grids C & D using 4 stabilizers, attaching the 2 vertical snap wires (V1) as you do it.

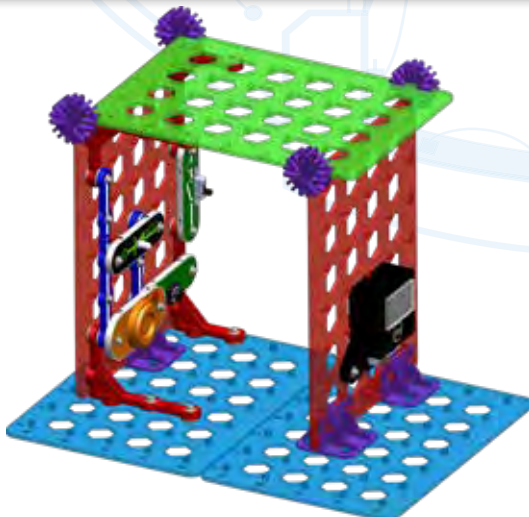

4. Place the remaining parts on grids A, B, & E, including the two blue jumper wires

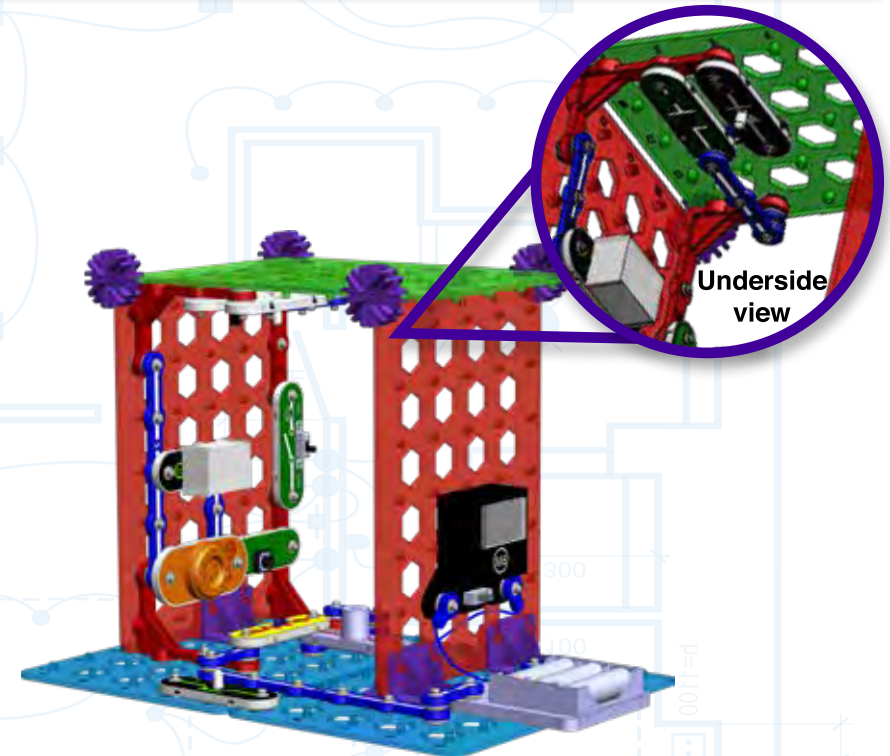

This circuit does not have an on-off switch, so connect one of the blue jumper wires last, and disconnect it when you are done using this circuit. Set the meter (M6) to the 50mA setting. Turn on the slide switch (S1) or push the press switch (S2) to make things happen, and watch the current on the meter. The lamp (L4) will not light.

The light covers and slides may be placed on the LEDs (D6 and D8) or lamp (L4) as decoration. Fold the slides as indicated and slide them into the slots on the cover, as shown.

You can replace either LED (D6 or D8) or the melody IC (U32) with the motor (M4) and fan. The motor represents a ceiling fan, fan for a furnace or air conditioner, or other appliance.

Go to [www.elenco.com/products/myhome](http://www.elenco.com/products/myhome) for an interactive 3D picture to help with constructing this circuit.



## This Circuit Demonstrates How Electricity Is Used In Your Home:

The **battery holder (B3)** represents the electricity supplied to your home. Usually the electricity is generated by a power station, but it could also come from a gasoline-powered backup generator, from solar panels on your roof, from wind turbines, or from larger batteries.

The **meter (M6)** is the meter that measures how much electricity you're using and reports it to your local electric company. This meter is usually located on the outside of your house or somewhere nearby. Your electric company uses this measurement to determine how much electricity you have to pay for. Electricity is measured in kilowatt hours (kWh), which is the amount of electricity needed to power a 1000W light bulb for 1 hour. The present cost of 1 kWh of electricity in the United States is around ten cents (\$0.10).

The **blue snap wires**, jumper wires, and vertical snap wires (V1) represent the wires in your walls, ceiling, and floor, by which electricity travels throughout your home to where it is needed.

The **press switch (S2)** turns on (or off) the color LED (D8, which represents your television or computer screen) and the melody IC (U32, which represents your stereo or sound device).

The **slide switch (S1)** controls the white LED (D6) the same way a switch on the wall controls a ceiling light.

The **470 $\mu$ F capacitor (C5)** keeps the white LED glowing for a moment after you turn off switch S1, giving you a little light to walk out of the room by. Try removing C5 and see how much faster the light turns off.

The **5.1k $\Omega$  resistor (R3)** represents various devices that are always on and using small amounts of electricity, like your refrigerator, hot water heater, computer, television, and Wifi. Change your M6 meter to the 0.5-mA setting and see how much current flows to R3 when the S1 and S2 switches are off.

The **lamp (L4)** represents a fuse and will only light if there is a problem in your circuit. Normally L4 will be off.

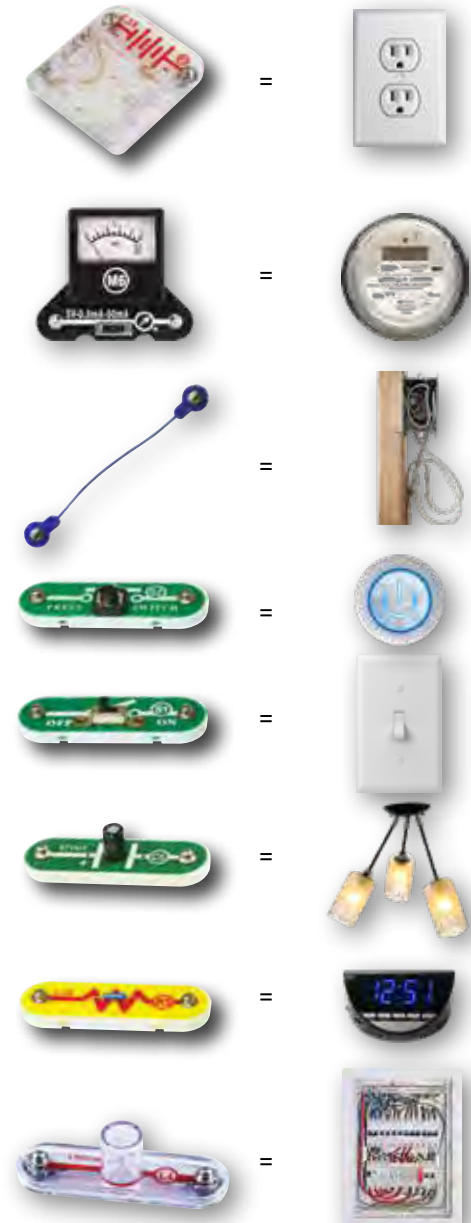







**Assembly (adult supervision recommended):**

1. Place base grid supports on base grid A & B.
2. Place parts (except for the jumper wires) on base grids C & D, and install into base grid supports on grids A & B. The pegs should be facing inward.

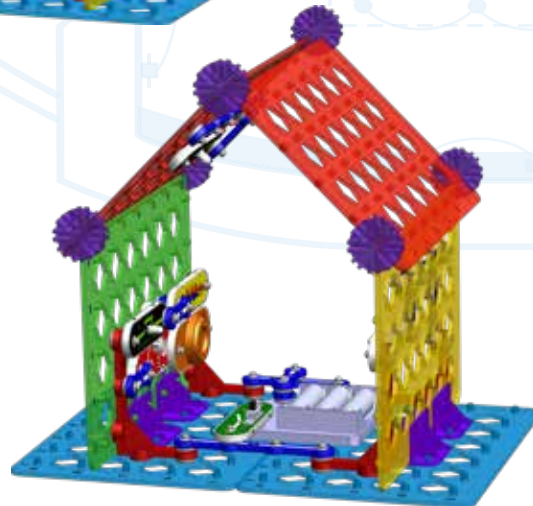
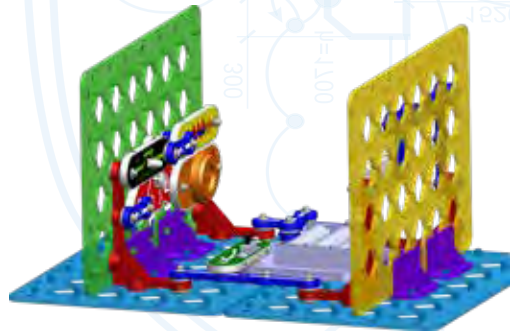
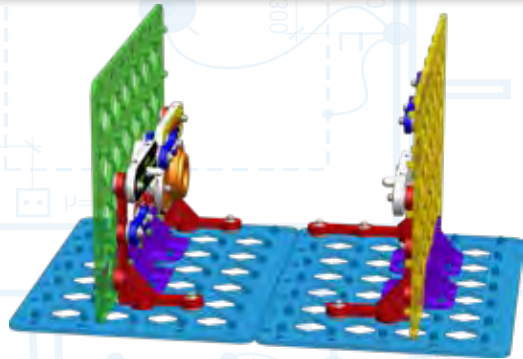

3. Place remaining parts on grids A & B.
4. Place parts (except jumper wires) on grid E.

Turn on the slide switch (S1); the white LED (D6) should be on, but there should not be any sound. Now place your hand between the white LED and the phototransistor (Q4); an alarm sounds and the color LED (D8) turns on.

Underside view

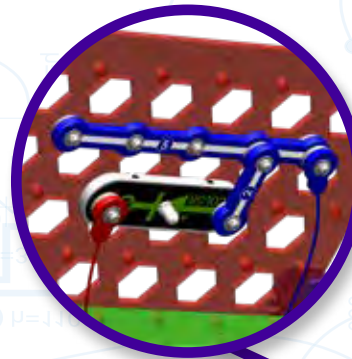

Other side view

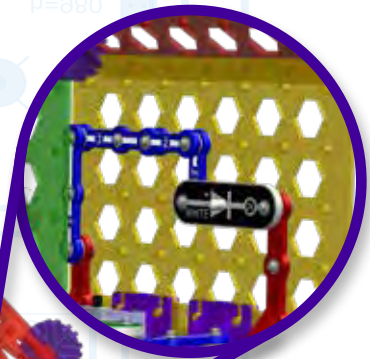

**Easier Roofless Version:** Skip assembly steps 4 and 5, and the jumper wires from step 2. Grids E and F, and all parts on them are not used. The circuit works the same way except that the color LED (D8) is not included.





# Project 10 | BLOCK THE SOUND

## Assembly (adult supervision recommended):

1. Place base grid supports on base grids A&B.
2. Place parts on grids C&D and install into base grid supports on grids A&B.
3. Install remaining parts on grids A&B.

Turn on the slide switch (S1); the white LED (D6) and melody IC (U32) are on. Place your hand to block the light between the white LED and phototransistor (Q4); the sound stops. **Hint:** The light in your room may be keeping the sound on, to check for this, try pointing the phototransistor away from your room light.

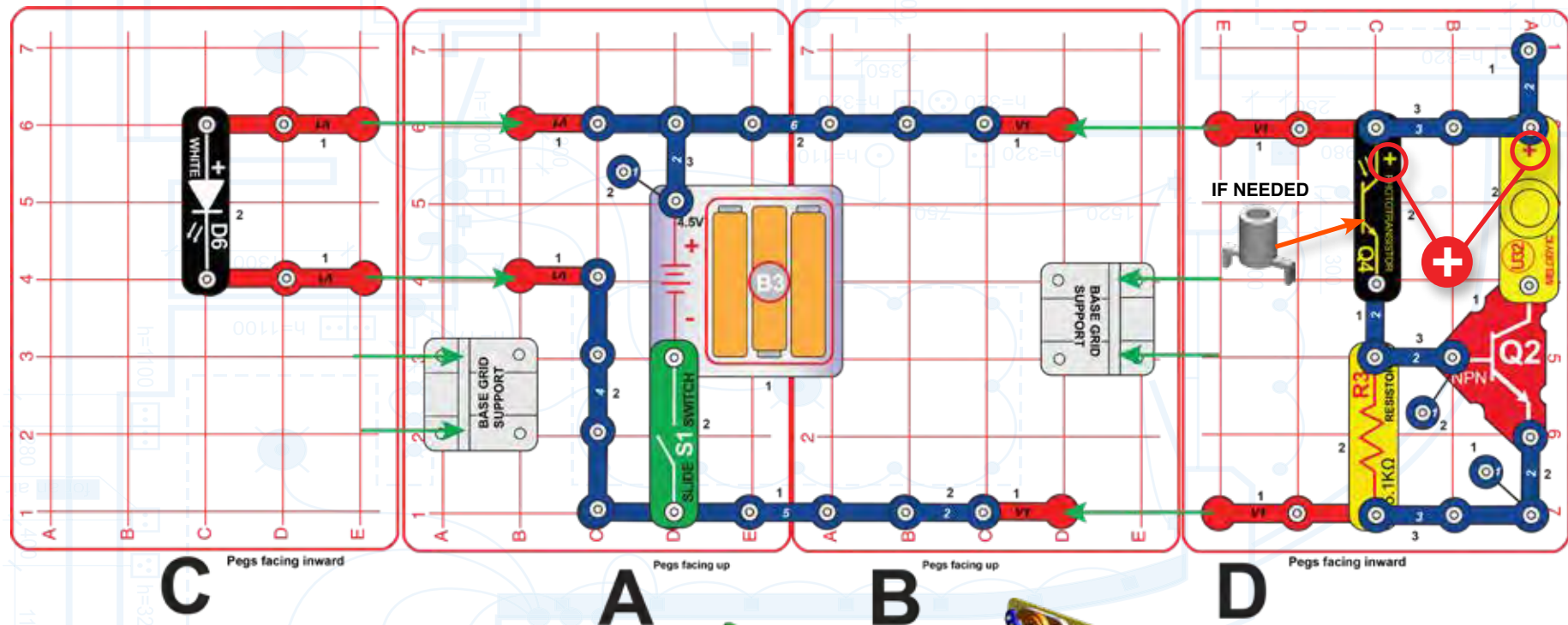

This circuit is the opposite of the Security House project (roofless version). The positions of resistor (R3) and phototransistor (Q4) have been switched, reversing how the melody IC (U32) is activated. Now the "alarm" is always on unless you block the light to turn it off.

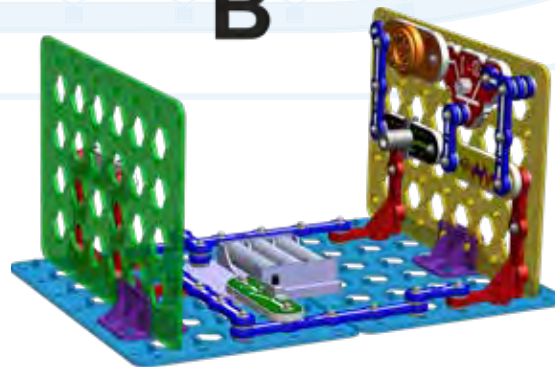

## Project 11 | MATERIALS TESTER

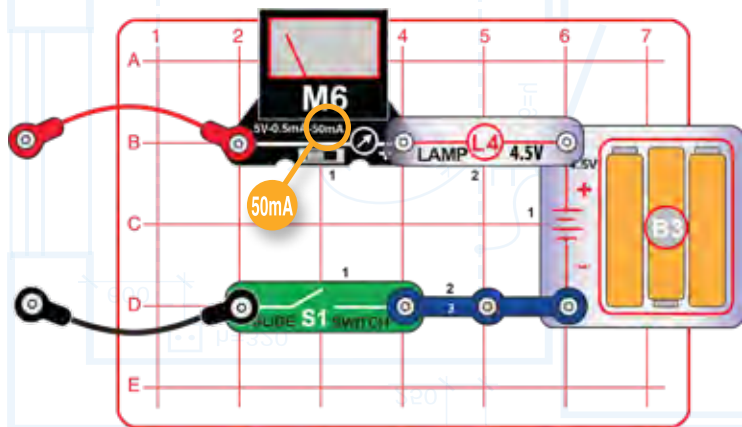

You can calculate the resistance of the materials you tested using Ohm's law: Resistance = Voltage / Current. From the information on your batteries, you know that the Voltage is around 4.5V, and you can measure the Current using the meter.

**WHAT IS RESISTANCE:** If you rub your palms together very quickly, they will begin to feel warm. The **friction** between your hands converts the physical motion of your body into heat. Resistance is the friction between an electric current and the material it flows through; and, like friction, resistance creates heat as well. We use electrical components called **resistors** to increase this electrical friction (resistance) to control how electricity flows through circuits. In this circuit, the resistor (R3) decreases the brightness of the LED, makes it dimmer but which also makes the batteries last longer.

Build the circuit and set the meter (M6) to the 50mA setting. Turn on the slide switch (S1) and touch (or connect) various materials between the loose ends of the red & black jumper wires. See which materials are good at transporting electricity by watching the meter current and lamp (L4) brightness. Try string, the electrodes, a shirt, plastic, paper, two of your fingers, wood, or anything in your home.

If the meter reads zero, switch it to the 0.5mA setting to see if there is just a very small current. To help protect the meter, always switch back to the 50mA scale before testing a new circuit.

Which materials gave the highest reading on the meter, and which gave the lowest?

Some materials, like copper, gold, and platinum metals, have very low resistance to electricity, meaning electrons travel through them very easily. This is why the lamp glows brightly and the meter measures a large current. Because we can conduct electricity (or make it flow) through these materials, we call them **conductors**.

Other materials, like paper, air, and plastic, have very high resistances to electricity, meaning they nearly block the flow of electrons completely. We call these kinds of materials **insulators**. If you incorporate these **insulating** materials into the circuitry, they cause the lamp to turn off and the meter to read a current of 0 even at its lowest setting (0.5 mA).

The best conductor known to humans is silver, but it would be very expensive to build circuits out of silver. Copper is the second-best conductor and, because it is much cheaper, it is used in almost all electrical wiring.



## Project 12 | DIM COLOR LIGHT

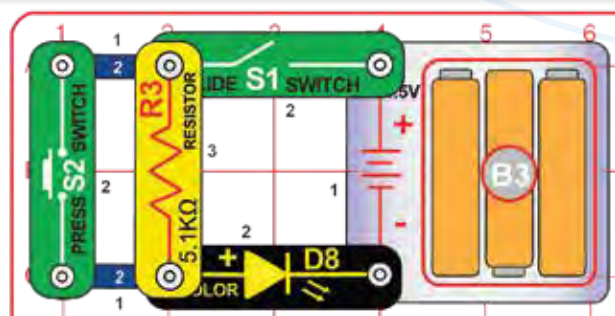

Build the circuit as shown and turn on the slide switch (S1); the color LED (D8) will be dim. Push the press switch (S2) to make the LED much brighter.

Next, replace the color LED (D8) with the white LED (D6) and compare the results.

# Project 13 | MINI BATTERY

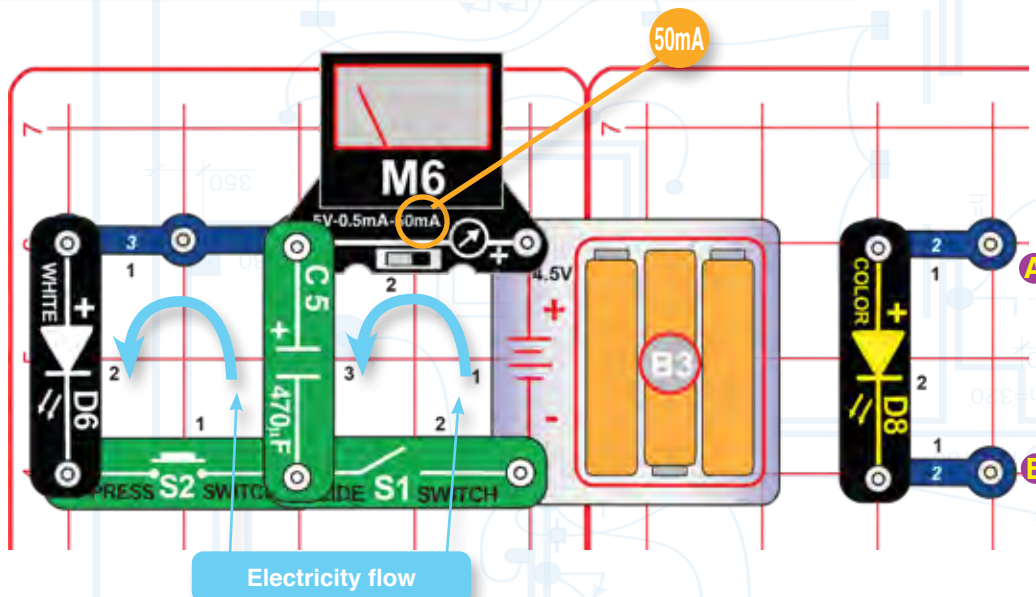

Watch the current measured by the meter. Turning on S1 allows electricity to flow from the batteries into capacitor C5, causing the current to increase; but the flow of electricity stops when C5 is fully charged (that is, when all the electrons that can crowd into the capacitor do so). In this way, charging a capacitor is a lot like filling a water tank – you can only push as many electrons/ water droplets into them as they can hold.

When S1 is off and you press S2, the electricity that is stored in C5 flows through S2 and lights the white LED. The LED stays lit until C5 is discharged, meaning all the electrons that crowded into the capacitor have dissipated or moved away. Dissipating a fully charged capacitor is like opening the valve at the bottom of a full water tank – once the path is cleared, both water and electrons will flow freely.

Build the circuit as shown and set the meter to the 50mA setting. Turn on the slide switch (S1) until the meter current drops to zero (indicating the 470µF capacitor (C5) is fully charged), then turn the switch off. Push the press switch (S2) to discharge the capacitor through the white LED (D6), lighting it. Turn S1 on and off and then push S2, several times.

Now turn S1 on and off, but then remove C5 from the circuit and place it across points A & B (“+” to A) and the color LED (D8) lights. Return C5 to the original circuit and repeat.

Pushing S2 while S1 is on connects the batteries directly to the white LED, and makes the effects of the capacitor difficult to see.

**Part B:** Replace the slide switch (S1) with the 5.1kΩ resistor (R3) and set the meter to the 0.5mA setting. Now the capacitor charges up very slowly, because the resistor limits its charging current.

Capacitors like C5 store electricity like tiny rechargeable batteries. Although they can't store as much electricity as batteries, capacitors can store and release electricity much faster than batteries. And, like a battery, a capacitor can store electricity for a long time. To demonstrate this, once C5 is charged, remove it from the main circuit and place it across the mini circuit containing D8.

Capacitors and rechargeable batteries are used in many devices in your home to store information, like the date or time, when the devices are turned off or when the power goes out in your home.





# Project 14 | STORING ELECTRICITY

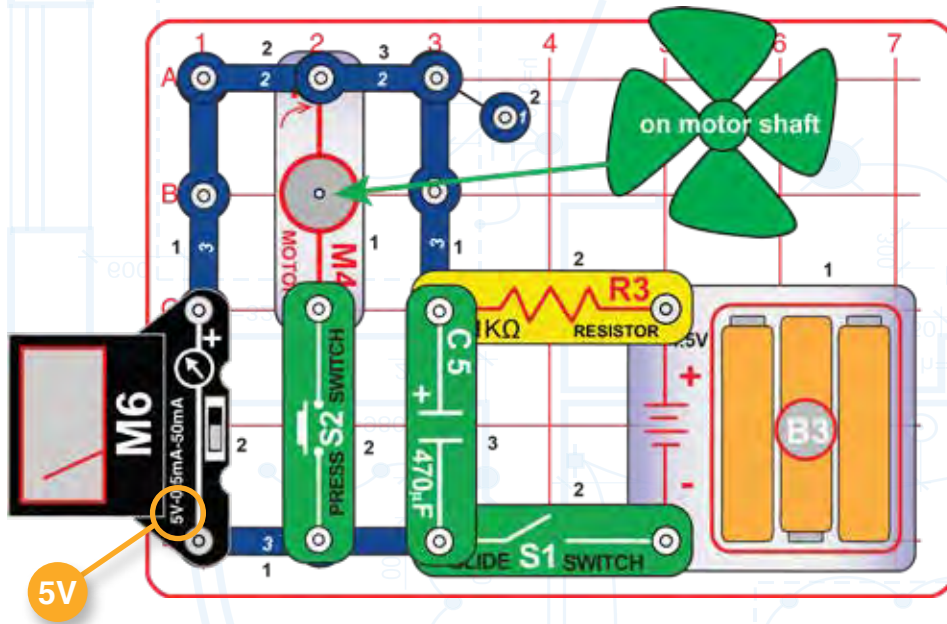

Build the circuit as shown and set the meter (M6) to the 5V setting. Turn on the slide switch (S1) and watch as the voltage slowly rises to 3V or more. Next push the press switch (S2) for a moment; the fan wiggles and the voltage drops to 0. Repeat this several times.

How it works: the 5.1kΩ resistor (R3) slows the flow of electricity from the batteries, causing the capacitor (C5) to charge up slowly and the voltage reading on the meter to increase. Pushing S2 discharges the capacitor, so that electricity flows through the motor. But the capacitor can only store enough energy to make the fan wiggle for a moment. Once the capacitor's charge has dissipated (meaning all the water has drained out of the tank), no more current will flow, so the fan does not move.

