

INSTRUCTION MANUAL

MODELING THE *AMERICA*

◆ SCHOONER YACHT, 1851 ◆

Original solid hull model instructions prepared by
Ben Lankford
Adapted to Plank-on-Bulkhead hull construction by
Edmund Fry
and *Victor Navas*
Revised instructions by Edmund Fry

Copyright 2020 Model Shipways, Inc Miami, FL

Technical Characteristics

Scale: 3/16" = 1 ft. (1:64)

Hull Beam: 4-1/4"

Height: 20-1/2" (top of main mast to bottom
of keel)

Overall Length: 25"; Hull Length: 18-1/2"



Manufactured by Model Shipways, Inc. • Miami, Florida
Sold by Model Expo, a division of Model Shipways, Inc. • www.modelexpo-online.com

Model Shipways Kit No. MS2029



HISTORY

During the early years of the New York Yacht Club, racing for prize money was the primary objective of most members. In 1851, a syndicate of NYYC enthusiasts built and raced America and captured the One Hundred Sovereign Cup at the annual regatta of the Royal Yacht Squadron, Cowes, England. In 1857, the trophy was donated to the NYYC, renamed the Americas Cup, and thus was the beginning of the Americas Cup races as we know them today.

The America was designed for the syndicate by George Steers of Long Island and built by William H. Brown on the East River in New York. The schooner was 101 feet in length on deck, 22-foot beam, 11-foot depth, 170 tons, with a sail area of about 5200 square feet. Over the years, the schooner was sold many times and eventually wound up in a shed at the Naval Academy in Annapolis, MD. The shed collapsed in 1942 and the Navy finally ordered the schooner broken up in 1945. There are two known replicas of America: The first, and considered the most authentic, was built in 1967 by Goudy and Stephens Shipyard in East Boothbay, Maine. A second one was built in Albany, NY in 1995, but this ship sports a modified fin keel.

KIT DEVELOPMENT

The original solid-hull Model Shipways kit was developed in 1967. The plans were drawn by and are the result of a reconstruction study conducted by the late English Naval Architect George Campbell, and are believed to be a close approximation of America as she raced at Cowes, England in 1851 to win the One Hundred Sovereign Cup

While the plans are reproduced from the 1967 version, the kit has been updated and reissued as a plank-on-bulkhead kit. Revised instructions are provided along with a more complete set of supplies for building the model. Note that the plans provided are the original plans, and do not depict the plank-on-bulkhead construction. However, the instructions include photos and diagrams to guide you. The fittings are cast from lead-free Britannia metal, and laser-cut wood parts are provided.



Construction Stages & Table of Contents

Before You Begin	3	1. Rigging Identification	18
Working With Plans And Parts	4	2. Block, Deadeye, Bullseye, And Line Sizes	18
What You'll Need To Start	4	3. Standing Rigging	18
Painting & Staining	5	4. Running Rigging.....	18
Stage A: Assembling The Hull	7	5. Sails And Sail Lines.....	18
1. Preparing The Keel	7	6. Applying Beeswax To The Lines	19
2. Making Rabbet Cuts.....	7	7. Seizing Rigging Lines.....	20
3. Assembling The Bulkheads.....	7	8. Fittings & Block Strops	20
4. Assembling The Deck Pieces.....	8	9. Rigging Tools & Belaying Lines	20
5. Install The Transom Pieces	8	Stage F: Mast & Spar Construction	21
6. Beveling Bulkhead Edges	9	1. Shaping The Masts & Spars.....	21
7. Installing Aft Bulwark Pieces	9	2. Assembling The Masts.....	21
.....	9	3. Shaping & Detailing The Spars	22
Stage B: Planking And Decking	10	4. Installing The Masts.....	22
1. Hull Planking	10	Stage G: Standing Rigging	23
2. Installing Decking	11	1. Forestay.....	23
3. Installing Bulwarks	12	2. Main Topmast Stay And Triatic Stay	23
4. Install Stanchions	13	3. Bobstay	23
5. Preparing And Installing The Rudder	13	4. Bowsprit Shrouds.....	23
6. Constructing The Cockpit	13	5. Fore & Main Shrouds	23
7. Installing Hawse Timbers, Knightheads, & Cap Rail	14	6. Boom Footrope & Topping Lift.....	24
Stage C: Mounting The Hull.....	15	Stage H: Running Rigging.....	25
Mounting Board With Two Pedestals	15	1. Jib (Fore Staysail)	25
Launching Ways.....	15	2. Foresail.....	25
Stage D: Adding The Hull Details	16	3. Mainsail	25
1. General Notes.....	16	4. Main Gaff Topsail.....	25
2. Completing The Bulwark Details.....	16	5. Final Touches.....	26
3. Constructing The Skylight (Aft)	16	Bibliography	
5. Installing Britannia Castings	17		
6. Remaining Deck Fittings.....	17		
Stage E: General Mastng And Rigging Information.....	18		

Before You Begin

America is an interesting model for beginner and expert alike. Laser cut parts offer a simple building method. Britannia metal parts eliminate creating metal parts from scratch. If new to ship building planking and carving skills will be learned and developed. Constructing the America model also will provide you with the opportunity to develop some scratch-building techniques. During construction, you may want to substitute some of the kit fittings with your own creations. By all means try them, especially if you think you can improve the model. If you

are a beginner, completing this model will prepare you for a more complicated model.

Before starting the model, carefully examine the kit and study the plans and the assembly instruction manual. Determine if all the listed kit parts are present using the parts list and instructions. Handling the parts will produce a better understanding of the kit's building requirements. Try to visualize how every piece will look on the completed model. Also, try to follow the building sequence and what must be completed first, or ahead of time and

what can be done simultaneously if you wish. For example, you may want to skip to the mast construction as you are working on the hull or waiting for glued assemblies to set or paint to dry. It is also suggested that all small fittings and hardware be sorted into labeled boxes or compartments to avoid loss during the building process.

Working With Plans And Parts

The Plans: Two Plan Sheets are provided - 1. Hull Plan; 2. Mast and Rigging Plan. In addition, photos and sketches appear throughout the instruction manual to further illustrate the various stages of construction. The America kit is manufactured to a scale of $3/16" = 1'$ and matches the plans. Consequently, most of the dimensions can be lifted directly from the plans using a tick strip. This is simply a piece of paper (a roll of calculator paper tape works very well). Mark a dimension from the plan onto the tick strip and transfer it to the model.

Make Allowances: Try to be exact when following the instructions but use common sense. Adjustments may be necessary to compensate for small differences in how your model is shaping up and how the parts are relating to each other. An old saying in the model building craft is that "if it looks right, it is right." Also check the photographs for various details before working on them.

Britannia Metal Parts: The America kit is supplied with Britannia metal, brass, as well as wooden fittings to eliminate problems in making such parts from scratch. Many of these fittings will require final finishing before installing on the model. Before painting the cast-metal fittings, clean them up by removing all the mold-joint flash. To do this, use a No. 11 hobby blade to cut or scrape the flash, then file or sand with fine sandpaper. It is also suggested that you clean the fittings thoroughly with warm soapy water before applying primer. Make sure they are rinsed thoroughly and allowed to dry before painting. Due to the molding process used; some deformed parts may be received or will have filled-in holes that will have to be drilled. These can be straightened by gently and slowly reforming with your fingers. Check with the plans and photographs to verify the reforming of the part(s); every effort was made to reproduce the parts accurately, but some deforming may occur during shipping due to the weight of the parts themselves.

Kit Lumber: Laser cut basswood parts are supplied in the kit. A word about laser cutting: a common misconception is that the parts should punch out of the carrier sheet. This is not so. Laser cut parts are retained in the carrier sheet by small bridges of uncut wood called tabs. Tabs can be oriented parallel to the grain or perpendicular to the grain. It is always better to cut through these tabs rather than try to punch out the parts by breaking the tabs. You may have to cut through not only the tabs but portions of the part outline that did not cut completely through the sheet. Turn the carrier sheet over and cut from the backside to release the part without damage.

What You'll Need to Start

The following tools and supplies are recommended for the construction process. Modelers who have built before may have their own favorites. Almost all are available at Model Shipways

web site, www.modelexpo-online.com.

A. Knives and Saws

1. Hobby knife with No.11 blades
2. Razor or jeweler saw

B. Files

Set of needle files

C. Sharpening Stone - Necessary to keep the tools razor sharp

D. Clamps - A number of clamps of various sizes are essential.

These include:

1. Spring clamps of various sizes
2. A few small C-clamps
2. Several wooden clothespins
3. Rubber bands

F. Boring Tools

1. Set of miniature drills: #60 to #80
2. Larger bits for holes such as mast and hawse pipe holes
3. Pin vise

G. Miscellaneous

1. Tack hammer
2. Tweezers (a few)
3. Small fine pointed scissors
4. Miniature pliers
 - a. Small round
 - b. Flat nose
5. Bench vise (small)
6. Soldering iron or torch
 - a. Solder (lead-free solder recommended)
 7. Beeswax block (for treating rigging lines)
 8. 1/2" or 3/4" masking tape
 9. Wire cutters (for cutting fine wire and strip metal)

H. Sandpaper

Garnet or aluminum oxide sandpaper (#100 to #400 grit)

I. Finishing:

1. Paint brushes
 - a. Fine point for details
 - b. 1/4" or 1/2" flat square for hull

J. Supplies:

1. Paints
 - MS4814 Hull Bottom Copper Red
 - MS4830 Black
 - MS4831 White
 - MS4828 Iron/Cannon black
 - MS4980 Natural Stain
 - MS4977 American Walnut
 - MS4969 Gold Metallic
 - MS4972 Clear Satin Finish
 - Optional: green, brown, blue, red, white, gold enamels to decorate stern eagle

4. White or Carpenter's (yellow) Wood Glue

5. Five-minute epoxy

6. Cyanoacrylate (Super) Glue

Note about glues: White or Carpenter's yellow wood glue will suffice for most of the model. Five-minute epoxy provides extra strength for gluing fittings. Cyanoacrylate (Super) glue, called CA glue for short, is excellent for quick adhesion. The best CA glue for most applications is a medium viscosity gap-filling type. The watery thin type is recommended only to fill a narrow crack by capillary action. For CA glue, you can also purchase a CA accelerator. A spray or drop of the accelerator will instantly cure

the glue. This is handy to eliminate clamping parts for long periods of time waiting for glue to harden. Use CA glue with caution. You can easily glue your fingers or eyelids together and the fumes can burn your eyes. It would be a good idea to have a bottle of CA debonder on hand. This product will dissolve the glue if you do get it on your body. A mix of 50/50 white glue and water is used on rope seizing and rope knots, which will remain flexible rather than CA which will harden rope, and CA should only be used on rope work very sparingly.

A word about gluing laser cut parts. Laser cutting burns through the wood and leaves a charred surface. This charred surface sometimes does not make good strong glue joints. It is recommended to lightly sand or scrape away the loose char before gluing. It is not necessary to remove all the char, unless a finished wood surface is required. In some cases, simply scraping with the back edge of a # 11 blade is sufficient.

Building Strategy – Before starting to build think about which build strategy would be best for you to follow. One approach is to clean, file, dry fit and paint all parts before starting assembly; the other approach is to clean, file, dry fit and paint sub-assemblies as needed. The following instructions will work for either approach. Perhaps the deciding factor is really how much space you have to work in and being able to organize all the parts at once. Regardless of the approach, the following instructions will address sub-assemblies of components to be worked on and then set aside for later assembly.

Painting & Staining

It may seem strange to begin an instruction manual with direction on applying the finishes to the model. Not so! Much time and effort can be saved, and a more professional result can be obtained if the finishing process is carried out during construction. Proper timing in application of finishes and the use of masking tape to define painted edges should eliminate unsightly glue marks and splotchy stained surfaces. In the end, following these general suggestions will be to your advantage.

Paint Colors:

The recommended color scheme for America is as follows:

Underbody

Copper red (or copper plating)

Topsides & Cap Rail

Black

Inside Bulwarks

White

Ironwork

Iron/Cannon black (a slightly greyish metallic black)

Masts

Natural Stain or varnished (light tan stain) except white from deck up to the mainmast, boom rest and to bottom of foresail on foremast. Also, paint hounds white on both masts.

Bowsprit

Black

Booms & Gaffs

White

Deck Planking

Natural Stain or Varnished (light tan stain)

Inside Cockpit

American Walnut or mahogany stain

Deck Furniture

White with American Walnut or mahogany coamings

Ship Boats

Black outboard, white inboard. Thwarts could be varnished (Natural or light tan stain).

Stern Eagle

Follow the color scheme given on the plan.

Bow Trailboards

White edge, gold carving with black background

Note: The plans also give some optional colors for the hull during non-racing times.

Paint:

Use a flat finish paint. Model Shipways line of acrylic paints are available in the recommended colors. You may also purchase an already assembled America paint kit from Model Shipways web site, www.modelexpo-online.com.

Primer:

Prime all woodwork to be painted and prime all metal fittings. Lightly sand the primed items. Use a putty or spackling compound brand to fill any scratches and defects, then re-prime.

Stains & Finishes:

For natural finished wood, use a protective coating after staining, such as low-sheen polyurethane varnish or Model Shipways Clear Satin Finish. For the deck and spars, Model Shipways stain or Minwax can be used. These are a combination stain-finish that will provide a light tone to the wood. The deck plank edges can be painted prior to installation with any dark color to simulate caulking.

The staining of all wood parts should be done before gluing, especially if any CA glue is used. The stain will not penetrate dried glue and leave ugly white areas in the finish.

Brushes & Procedures:

Use good quality soft sable or synthetic hair artist's brushes. A small pointed brush is good for details. For the main hull areas, use a 1/4" flat brush.

Before painting, clean the model with a tack rag. Apply your paint in smooth and even strokes, overlapping them as you go. Thin the paint enough to eliminate brush strokes, but not run. You will need three or four coats of the light colors to cover the grey primer and maybe only two coats of the dark. Check your finish between coats and sand and add spackle as necessary to get rid of any blemishes. Anywhere two colors meet, such as the hull waterline, use masking tape. Electrician's black plastic tape or any of the hobby tapes made of plastic film are ideal. They leave a nice edge and are not overly sticky. Do not use drafting tape unless it is Chart-pak brand. The edges are somewhat wrinkled and paint may run under them. A good trick; seal the edge of masking tape with a clear flat finish and let dry thoroughly. This will prevent paint from running under the tape.

Selection of the types of clamps used.

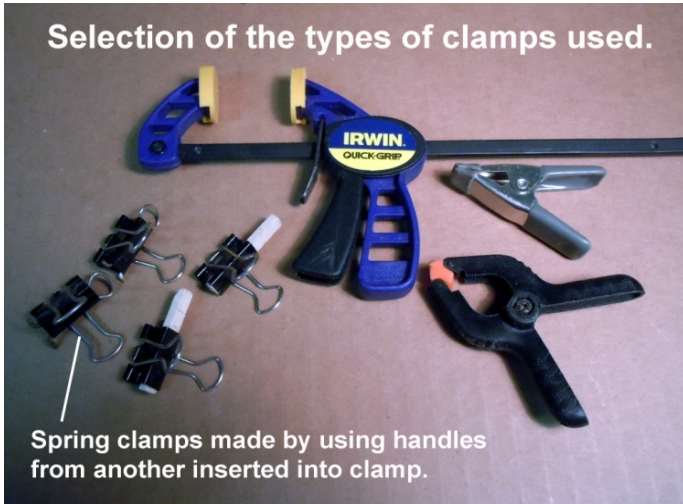

Spring clamps made by using handles from another inserted into clamp.

Britannia Metal Parts

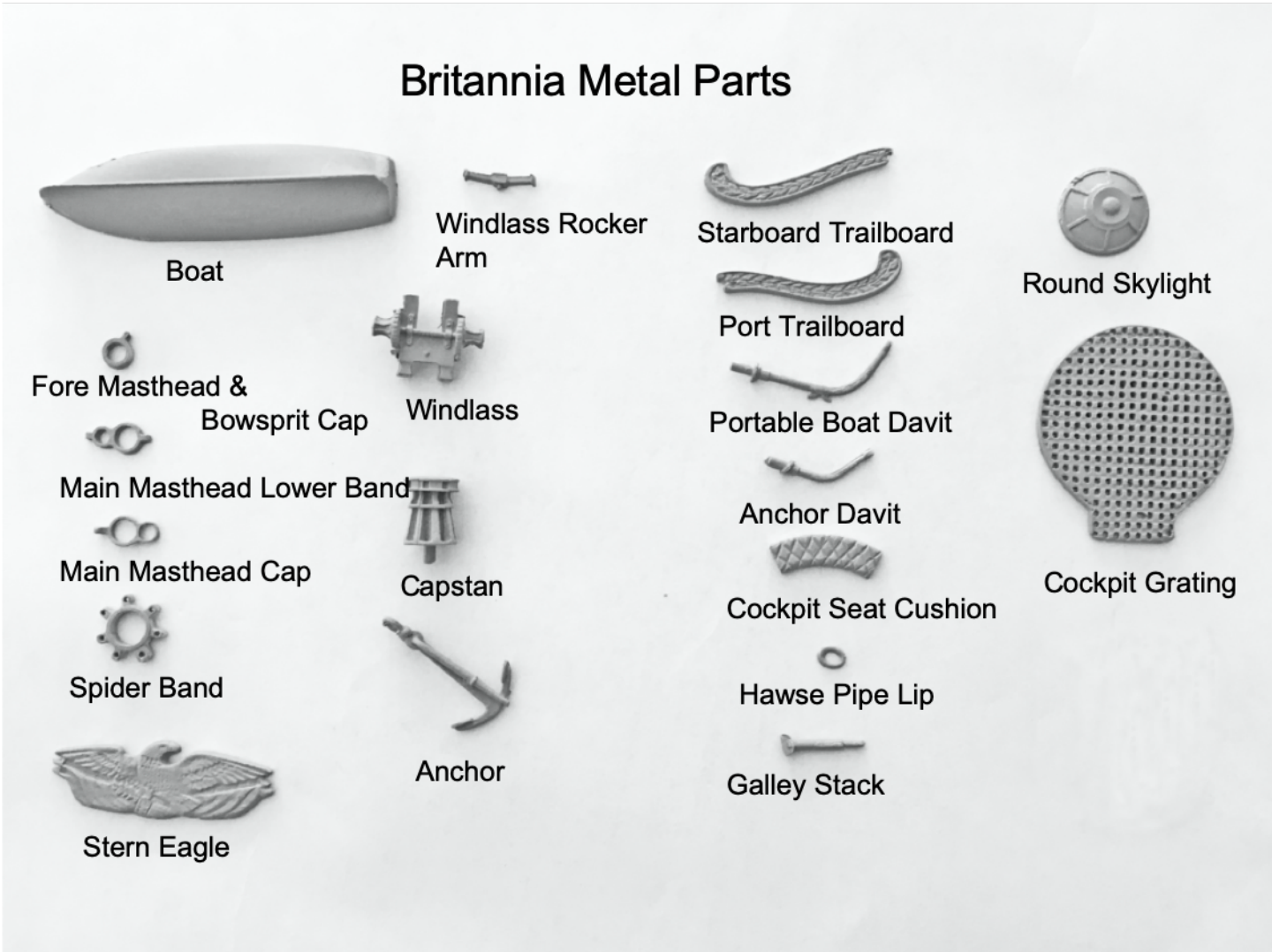

STAGE A: Assembling the Hull

1. Preparing the Keel

Remove the three Keel (#10), Stem (#9) and the False Keel (#6) laser cut parts from the carrier sheet. Carefully sand the laser char from all edge surfaces to clean wood and take care not to remove too much material. Dry fit them to understand how they fit together. Draw 1/16" spaced lines on the bottom edge of the False Keel part. Next trace the curved "Bearding Line" printed on the keel to the opposite side using a small piece of tracing paper so that the laser cut guideline is duplicated on both sides.

2. Making Rabbet Cuts

Now very carefully carve and sand the Rabbet Cut (Fig. A-1) using the laser cut and traced pencil lines as guides. The rabbet cuts extend from the stern as shown, along the bottom of the false keel, and up the bow of the false keel to the top. **IMPORTANT** do not cut away the laser cut "Bearding Line", it will be needed later to set the Bulkheads. These cuts will be filled with planks later. The remaining 1/16" wide flat surface on the bottom edge of the false keel should be straight and centered

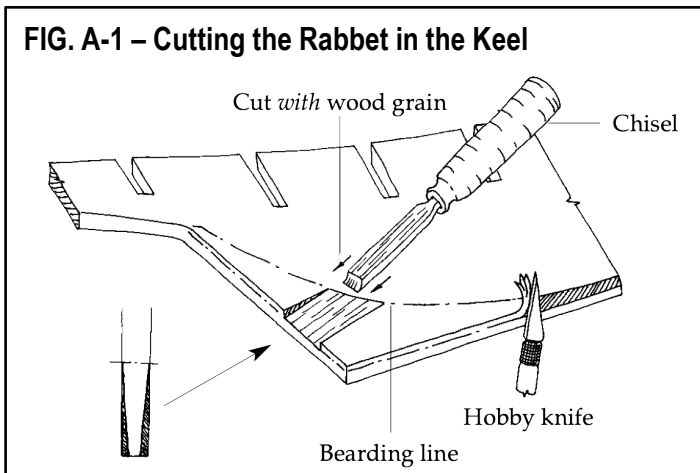

FIG. A-1 – Cutting the Rabbet in the Keel

the length of the part. **IMPORTANT** these cuts are critical so use care to get them equal on both sides and edges.

Once satisfied with the rabbet cuts it is time to glue together the bottom keel and the stem piece to the false keel. Fold an 18" length of wax paper lengthwise. Working on a hard, flat surface place the parts on one half of the wax paper; glue will not stick to the wax paper. Now apply wood glue to the 1/16" edge of the the False Keel that touches the Keel and the stem section. Place the keel and stem section in position against the false Keel making sure all surfaces touch. Now with a damp paper towel and a pointed scrap piece of wood scrape away any excess glue in the rabbet cut. Once one side is clean carefully flip the assembly over and clean the other side. Once cleaned fold the second half of the wax paper over the assembly and weight them down with heavy objects and allow to set for a couple of hours to be flat. Use clamps to hold the keel parts firmly against the false keel. Do not glue the sternpost section yet.

Now would be a good time to paint all the cast metal parts while waiting for glue to set on Keel parts. Metal parts **MUST** be

primed first for good paint adhesion. Set painted parts aside once painted for later assembly. Some of the small parts may have holes filled during casting; check and device such as the Model Shipways "Fair-A-Frame". Alternatively, attach to a flat board two wood strips about 10mm thick perfectly aligned, so as to form a groove just wide enough to fit the keel snugly. Set drill holes as needed. Painting parts now gives ample time for paint to cure and saves time later on during assembly of kit.

FIG. A-2 – Assembled Keel and False Keel



Once the glue has set on the keel parts the bulkheads and deck parts will be added. It will help greatly to mount the keel rigidly in a keel vise or the keel into the groove so that it remains in a vertical and straight position.

3. Assembling the Bulkheads

The bulkheads are labeled A through O from bow to stern. Remove the individual bulkheads from the carrier sheet and sand the char from the edges and surfaces of the Bulkheads. Dry-fit into position with the bottom edge of the Bulkhead aligning with the laser cut mark of the rabbet cut. Make sure the bulkhead letters all face forward towards the bow. Do not glue yet.

FIG. A-3 – Making Sure Bulkhead & Keel Surfaces Are Flush

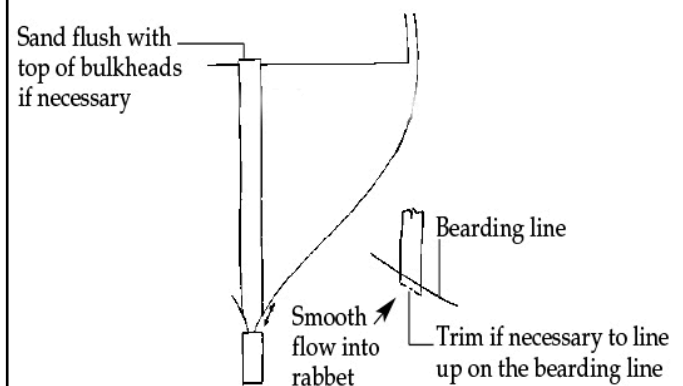

IMPORTANT The bottom edges of the bulkheads align with the laser cut mark on the keel, and the top center surfaces align with the top edge of the false keel. And when in the curved bow and stern sections; the stern front edges align with the laser cut mark, while the bow rear edges align with the laser cut mark. If a Bulkhead does not match when dry fitting, carefully remove wood from the bottom of the Bulkhead indexing notch only. See Figs. A-3 and A-4.

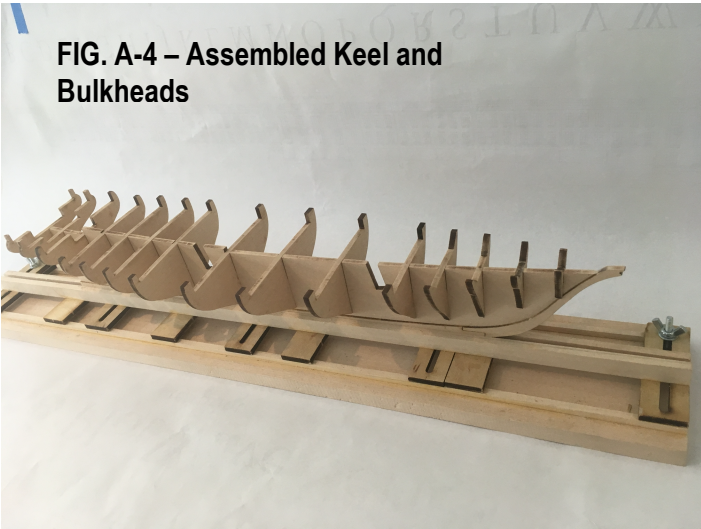

FIG. A-4 – Assembled Keel and Bulkheads

4. Assembling the Deck Pieces

Remove false deck pieces #11 and #12 from the carrier sheet and dry-fit them atop the bulkheads, fitting the bulkhead tabs into the deck piece slots. The deck pieces should lay flat on top of the bulkheads and false keel, with a 1/16" x 5/32" strip added between the deck pieces atop bulkhead H to form a step. Make sure the top of bulkhead H aligns with the top edge of the forward (lower) part of the false keel. See Fig. A-5.

The bulkheads and false deck should be self-aligning, and the parts must not be forced. Small corrections may be made by retouching the depth of the grooves on the keel or the false deck pieces, filing the bottom of the groove if the bulkhead is too high, or inserting a suitable shim if it is too low. Be sure the keel is perpendicular to the deck surface. Check the alignment of the whole structure observing it from various angles, and when everything is right, take the assembly apart and glue it back together using yellow glue starting with gluing the bulkheads to the keel, and then the deck pieces to the bulkheads. Align the deck pieces so that the edges are even with the bulkhead edges, and do not stick outside. Temporarily pin the deck pieces to the bulkheads and if necessary, pin the bulkheads to the keel and use clamps on the bulkhead tabs to hold the deck pieces while the glue dries.

Work slowly and carefully for it is critical that the Bulkheads are in the correct position when adding the planking later on. One advantage of using the Yellow Glue is that it affords a little time for cleaning off of excess glue and aligning each frame as it is added to the previous bulkheads. Also, if a bulkhead is found later to be out of alignment and the glue has set, just soak the joint with acetone and it will loosen the joint. Remove the

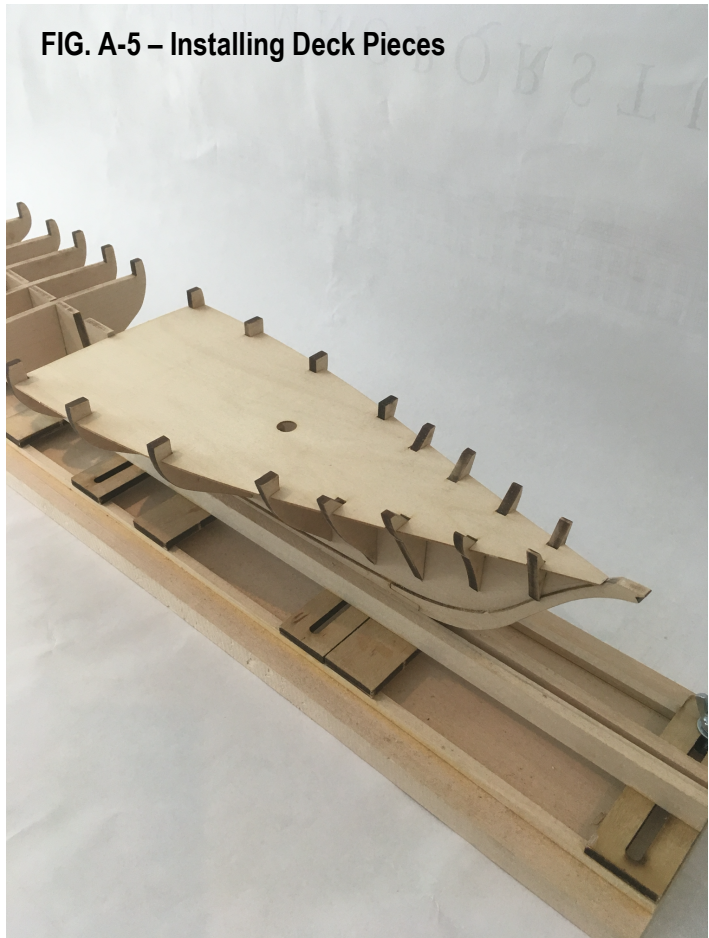

FIG. A-5 – Installing Deck Pieces

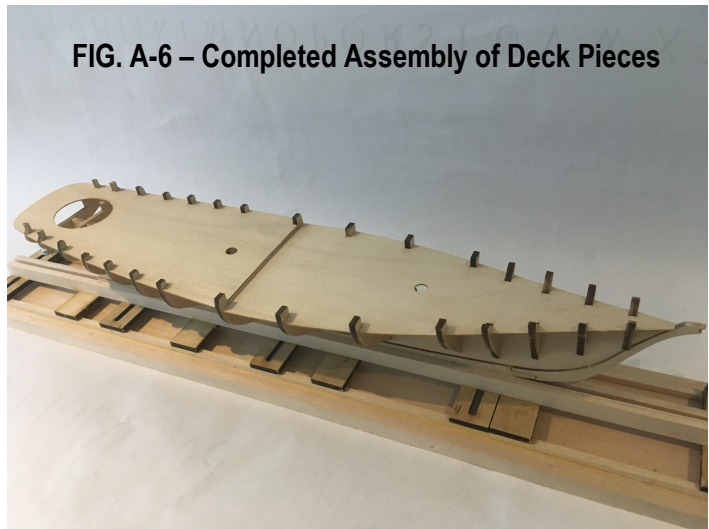

FIG. A-6 – Completed Assembly of Deck Pieces

bulkhead, clean and sand if necessary and re-glue into proper alignment. The acetone will take a little time to work to debond and may need additional applications.

Leave the bulkhead tabs in place. They will be removed later but are needed for now.

5. Install the transom pieces #1, #2 and #3. Use a file and sandpaper to make a smooth, rounded stern as in the photo. Install the two bow fillers, #4 in the space under the deck just forward of bulkhead A (Figs. A-7, A-10).

FIG. A-7 – Transom Pieces

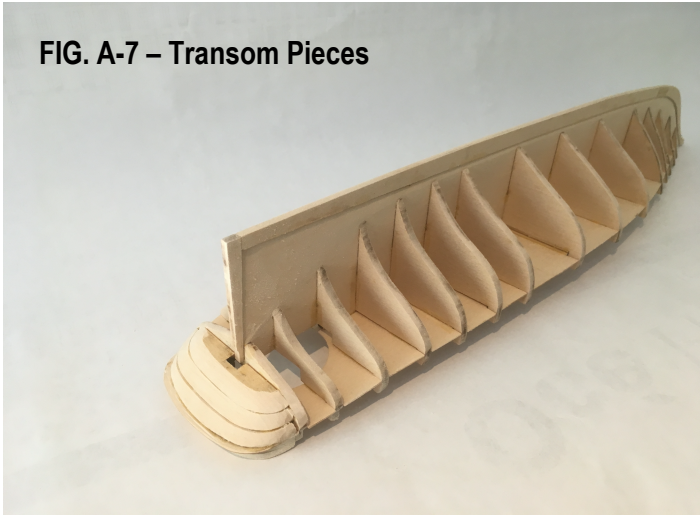

FIG. A-9 – Bulwark Pieces



6. Beveling Bulkhead Edges

The bulkhead edges must be beveled so that the hull planks will lay flat upon them when glued in place. Using a knife and sanding block (or sandpaper wrapped around a piece of flat wood about 1" x 6"), bevel the bulkhead edges beginning from the

middle towards the stern and the bow. Make smooth curves meeting the transom and the bow filler pieces (Fig. A-8).

FIG. A-8 – Shaping the Bulkheads

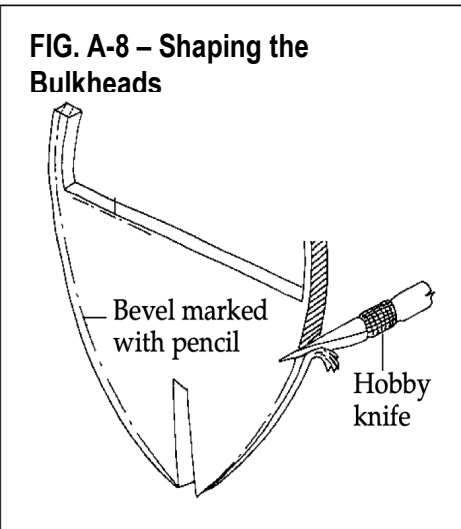

Check the correct adjustment by placing a planking strip along the bulkheads at different places and looking for gaps or bulges. Take care not to alter the profile of the upper

part of the last bulkhead (bulkhead O).

7. Installing Aft Bulwark Pieces

Glue the 2 bulwark pieces #21 (stacked) on the deck and against bulkhead 15. These must be adjusted so that the back end of the deck sticks out about 1/16" behind the bulwark #21 (Fig. A-9).

FIG. A-10 – Bow Filler Pieces



STAGE B: Planking and Decking

1. Hull Planking

A word about clamps, you cannot not have too many clamps, as well as a good assortment of rubber bands. Above is a picture of the various types of clamps used during the planking of the hull and more will be discussed later before the actual planking.

Now onto the more challenging step of hull planking. The best technique for this is to edge glue the entire plank edge joint to the next plank using Yellow Glue. Yellow Glue provides time to set the plank in place with clamps and more importantly can be easily sanded and does not harden the wood like CA would. The kit planks are 1/16" x 3/16" x 24" and thus do not require end butt joints. A small plastic container or drinking glass with hot water will be needed to soak the ends of planks to be formed by hand to conform to the Bulkheads. Wood absorbs water up the end grain, so the longer in the hot water the more water is absorbed and makes the wood strip more flexible. This is what is needed to be able to form the curved bow planks. Edge bending will also be needed for some planks; this can be done by placing a wet plank on a flat surface and slowly bend the edge of the plank while pressing down flat on the surface while bending. All bending and forming should be done very slowly allowing the wood fibers yield slowly while being formed.

The first (gunwale) planks will be 5/64" x 1/8" basswood. Install one on each side as even with the top of the deck sheet as

FIG. B-1 – Installing Gunwale Planks

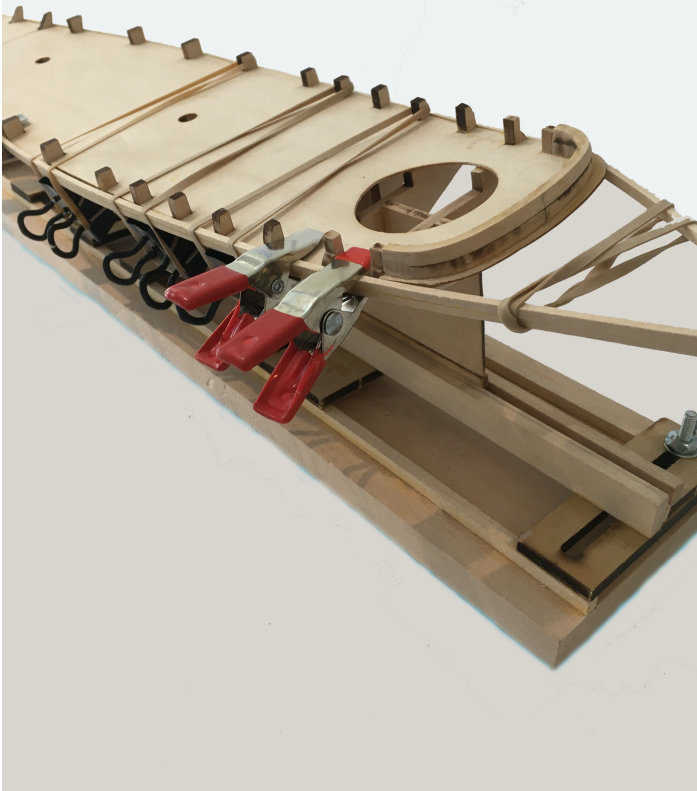
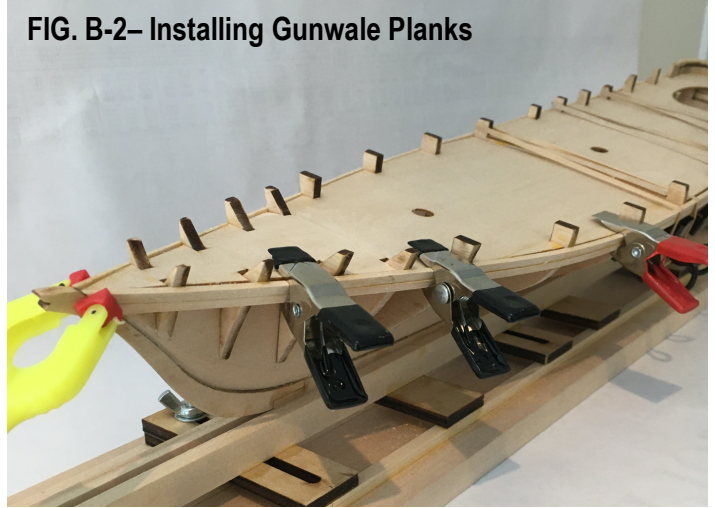

FIG. B-2– Installing Gunwale Planks



possible, starting even with the deck sheet at the bow and ending even with the deck sheet at the stern, recognizing that the deck step in the center will not allow this plank to be completely even with the deck surface along its entire length. This plank, and all others, will be beveled as needed to fit smoothly into the rabbet cut. Then, install another 5/64" x 1/8" plank on each side below the first and tightly against it. Use clamps and rubber bands anchored on the bulkhead tabs (Figs. B-1, B-2).

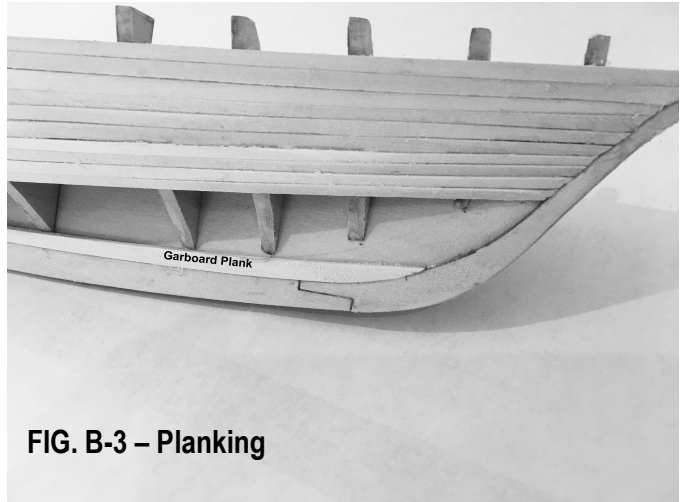

FIG. B-3 – Planking

After these first two strips on each side are in place, begin the rest of the planking using 1/16" x 3/16" strips. Start with a strip along the bottom of the false keel (garboard plank), beveled as needed to make a tight smooth joint in the rabbet cut at the keel. Cut a curve at the bow end of the plank to allow it fit into the rabbet cut at the forward end without edge bending. Leave a slight overhang at the stern end – after all planks are installed, the stern ends will be sanded flat against the back of the keel so the sternpost can be glued in place with no gap. Note that the thickness of the stern end of the keel, including planks, must be 3/16" so the rabbet cut on the false keel must be tapered accordingly.

Apply an identical strip (garboard plank) to the other side of the

hull, and as with the first side, bevel and slant the forward edge to form a pointed bow in line with the keel (Fig. B-3)

The following is a suggested approach for the rest of the planking, but if you are experienced feel free to use your own methods. Carefully measure down 1-7/8" on bulkhead H from the bottom of the lower 5/64" x 1/8" gunwale plank and make a pencil mark on the bulkhead edge. This distance represents the width of ten 3/16" planks. Place a temporary plank against bulkhead H with its top edge aligned on the pencil mark, pin it on bulkhead H and place it flat so it follows its natural course against the bulkheads from bow to stern with no edge bending (Fig. B-4). Pin it against the bow and the rearmost bulkhead.

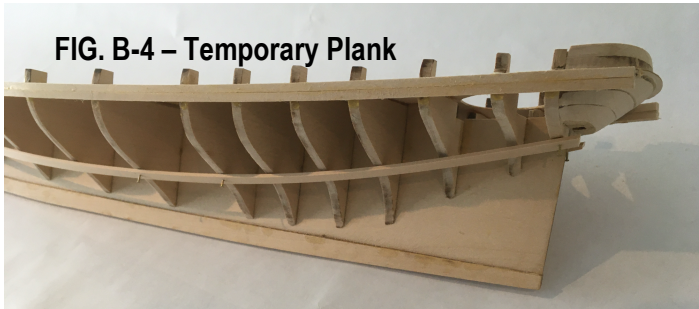

FIG. B-4 – Temporary Plank

Then, make a pencil mark on each bulkhead at the top of this temporary plank. This will help in forming the rest of the planking. Do this on both sides of the hull.

At this point, you can measure the distance from the lower edge of the gunwale down to the top edge of the temporary plank along the edge of each bulkhead. A paper strip can be used to get an accurate measurement. Dividing these measurements by 10 will give you the width that each of the first 10 planks must be at each bulkhead. Each plank will be 3/16" wide at bulkhead H and will be narrower toward the bow and toward the stern. You can plot these measurements along a line drawn on the paper plans to help with measuring as you carve and sand each plank to the required shape. Ideally both sides of the hull will be identical but make allowances if not. You can now remove the temporary planks and begin planking.

Plank installation should be started at the top, indexing tightly into the bow rabbet, tight against the plank above, and glued to each bulkhead with a thin line of glue along the edges to fasten to adjacent planks. Don't forget to leave a slight overlap at the rear end of the keel. Where the hull shape turns, bevel the edges of the planks slightly so the edges will fit together tightly without a gap. Use clamps and blocks imaginatively, being careful to avoid dents in the basswood. Use the bulkhead tabs to anchor rubber bands stretched around the hull. Wipe glue squeeze-out with a damp sponge as you go.

Add planks vertically to the stern as shown, using narrower strips. Carve and sand the rear end of the keel straight and square, and add the laser cut stern piece.

Once the hull planking is complete, sand smooth and fair, starting with 100 grit and then 220 grit. Sand the bottom and sides of the stern piece to create a smooth, seamless look. The bow will be pointed. Fill any significant gaps with basswood slivers, and any remaining gaps or imperfections can be filled

with automotive body putty.

2. Installing Decking

You are now ready to install decking. First, snap off the bulkhead tabs with pliers, and chisel and sand the tabs flush with the false deck surface. The first pieces to install are the waterway strips, the 1/32" x ___ strips that are glued along the outside edge of the decking (both the upper aft part, and the lower forward part). These waterway strips, which could be called margin strakes, are the same thickness as the deck planking. They will be glued to the sheet basswood deck "underlayment", so they align with the edge of the sheet, inside the gunwale strips. The technique to glue them in place is to use scrap basswood plank remnants cut and shaped exactly to lay across the deck 1/16" inside each edge, so they will spread the waterway strips to sit exactly in place. Use these spreaders every few inches. Trim the bow ends of the waterway to meet just behind the stem piece as shown in the photo (Fig. B-5). Soak the strips to make them pliable and get rubber bands ready. Place the waterway strips on the deck, stretch several rubber bands around the hull, and start putting the spreader strips in place. Stretch a rubber band across the top of each spreader strip, and elsewhere as needed to keep the waterway strips flat against the deck. When the waterway strips are completely dry, they will more or less retain the shape of the deck. You can now apply glue to the bottom surfaces and glue them in place using the same spreader technique. Take care to get

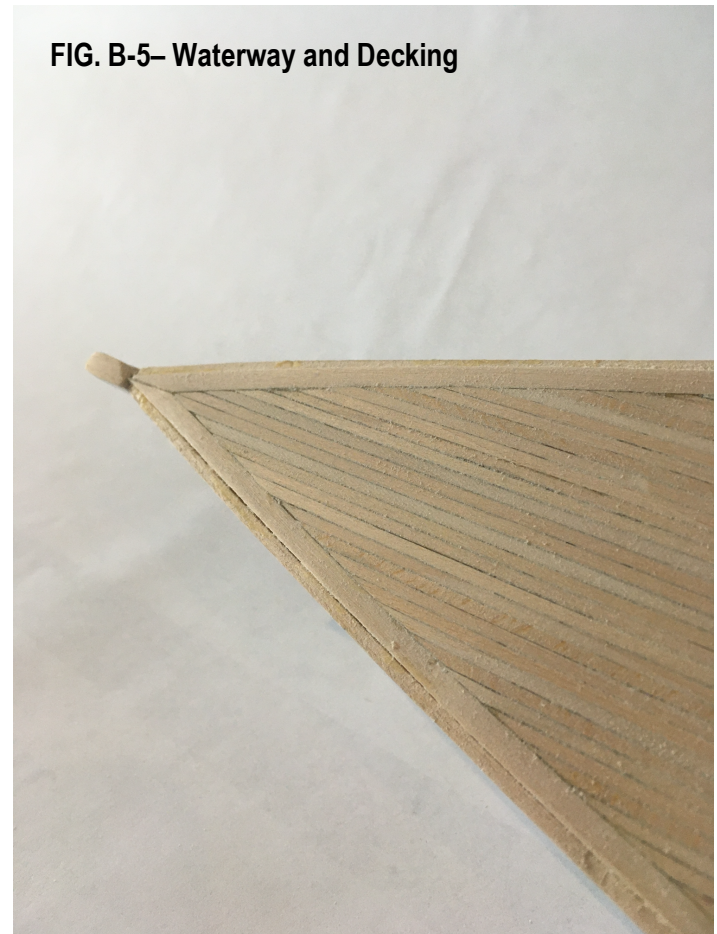

FIG. B-5– Waterway and Decking

the position of the waterway strips exact and avoid gluing the spreader strips to the deck.

This kit includes individual decking plank strips in lieu of scored

plank sheet found in the original America kit and many other solid hull kits. The decking consists of 1/32" x 1/16" strips glued fore-and-aft. Joint caulking that would be apparent in a real ship should be simulated. Black paint along the edges of the decking strips can be used, but it would be easier to use a soft pencil. Start with two deck strips down the centerline of the deck and work outward. Be sure to mark and cut the mast and cockpit openings before they are covered. Shape the strips as needed to fit against the waterway so that the result is a deck as shown in Fig. B-5. For the upper (rear) deck surface, let the decking strips slightly overhang the deck step so that the ends can be sanded precisely square when installing the deck step strip.

Strip at the deck step: the butt strip across the midship deck step on the aft deck is 1/16" x 5/32". Install this next (Fig. B-6).

When the decking is complete, sand smooth and flush, make sure glue residues are removed and apply a light stain and/or combination stained varnish. Try to avoid varnishing the gunwale planks, as the bulwarks will be glued to their upper surfaces.

FIG. B-6– Deck Step



3. Installing Bulwarks

Soak a length of 1/16" x 1/8" basswood strip and bend it around the aft side of the stern bulwark pieces (#21), and when dry, glue into place against #21 and sitting tight on the deck (Fig. B-7). Repeat with another strip glued against #21 and sitting atop the first.

In the next step, the 1/32" x 1/4" bulwarks are installed. This

FIG. B-7 – Installing Stern Trim Strip



somewhat tricky operation involves first edge-bending the strip to match the deck sheer (longitudinal curvature of the deck). Soak a 24" strip and clamp it flat to a board or table so that the middle is on the edge of the board and each end is about 1/2" from the edge. Use enough clamps to ensure that the entire length will be flat without distortion (Fig. B-8). When dry, the clamps can be removed, and the strip will retain the curve of the deck sheer. Trim the strip to length so it can be glued against the laser cut stern bulwark pieces #5 with about 1/4" overlap and will fit against the side of the bowsprit when it is installed. Now, paint

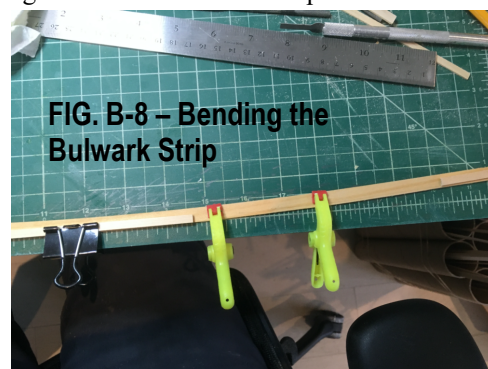

FIG. B-8 – Bending the Bulwark Strip

the inside surface white before installing.

The bulwarks are glued into place atop the upper gunwale plank using spreader strips and rubber bands as you did for the waterway strips. This time, the 1/4" spreader strips are trimmed square and positioned vertically (on edge) across the deck every few inches, so that the bulwark will fit against the ends of the spreader strips and be vertical when glued. Make sure the rubber bands are positioned atop the spreader strips, so they don't distort the upper edge of the bulwark strip. Unlike the waterways that are in two pieces on each side, the bulwarks will be installed one piece per side glued atop the gunwale plank and fitted against the outer edge of the waterway strip. Fig. B-9 shows the technique.

4. Install Stanchions

Once the bulwarks are in place, paint a strip of 1/16"x1/8" basswood white, leaving one side unpainted for gluing, and cut 1/4" lengths from it to install stanchions on the inner surfaces of the bulwarks as shown on the plan sheet. The stanchions should be 10mm (about 3/8") apart; it is suggested you use a small block of wood exactly 10mm wide to use as a spacer as you go. Then install the hawse timbers, also painted before installation.



FIG. B-9 – Installing Bulwarks

5. Preparing and Installing the Rudder

The rudder #7 is also a laser-cut part and can be shaped and installed now or later. Use a file to trim the hull opening for the stock as necessary. The rudder is tapered and has a round front edge. The stock portion is round. The tiller, a laser cut part, can be fitted after the rudder is installed. The pintles & gudgeons are made from brass strip - see Fig. B-10 for construction. File the

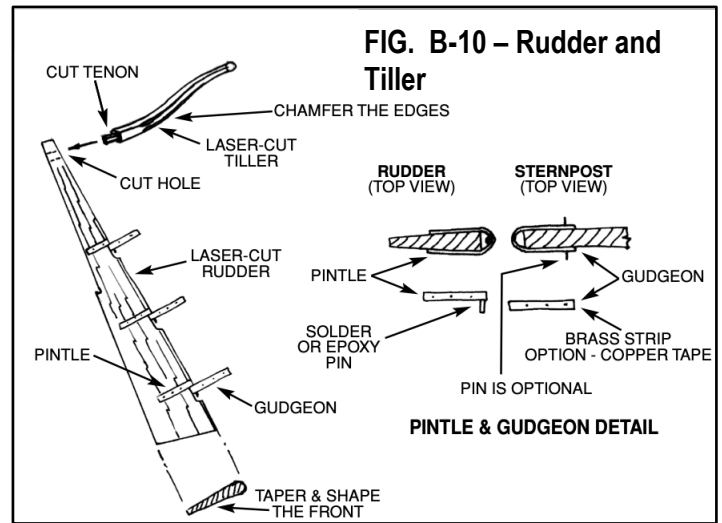

stern hull opening as needed to allow room for the rudder stock. You may install the tiller at this point.

6. Constructing the Cockpit

You may paint the pieces before installing, which will make the paint details cleaner, and as an option, you can build the companionway before installing the cockpit components. Fig. B-11 provides some details of the cockpit. First, sand the edges of the decking to make a clean circular opening. Using a small chisel blade, carve the bulkheads as needed to be flush with the cockpit opening. Glue the laser cut circular cockpit floor #12A to the top of the false keel and bulkhead N being careful to center it exactly in the cockpit opening. Glue the Britannia metal cockpit grating to the floor, also centered exactly, with the rectangular part extending forward.

Build the cockpit coaming, using 1/32 x 5/64 x 1/2" vertical strips edge-glued around the cockpit opening leaving a space at the front for the companionway. One technique is to glue them together while formed around a circular object the same diameter as the cockpit opening (a Model Expo paint bottle is the perfect size). Cut out the opening for the tiller, then install the assembled coaming in the cockpit glued on the floor and against the sides. Sand the top edge to be even and parallel to the deck surface, with the top about 1/8" above the deck.

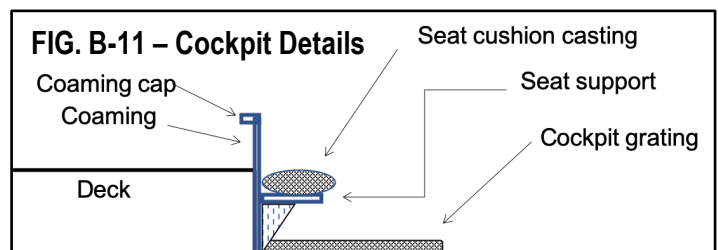

Then install the laser cut seat supports #13. These two semicircular parts meet at the back of the cockpit and leave an opening at the front for the companionway. They should be mounted on 3/16" risers so that the Britannia metal seat cushions can be glued atop the seat supports, with the upper surfaces at or just below deck level. The Britannia metal cushion ends must be filed to fit. The seat supports may be supported with turnings if desired. Attach the laser cut cap pieces #14 atop the coaming

FIG. B-12 – Cockpit Details



(Fig. B-12).

7. Installing Hawse Timbers, Knightheads, & Cap Rail

Install hawse timbers and knightheads first, then the cap rail. The hawse timbers and knightheads are butted together at the bow forming a solid area. The timbers are the same thickness as the stanchions. Note that the cap rail at the bow butts against the sides of the bowsprit and does not go over top of the bowsprit. See Fig. B-13 for bulwark details.

FIG. B-13 – Stanchions and Hawse timbers

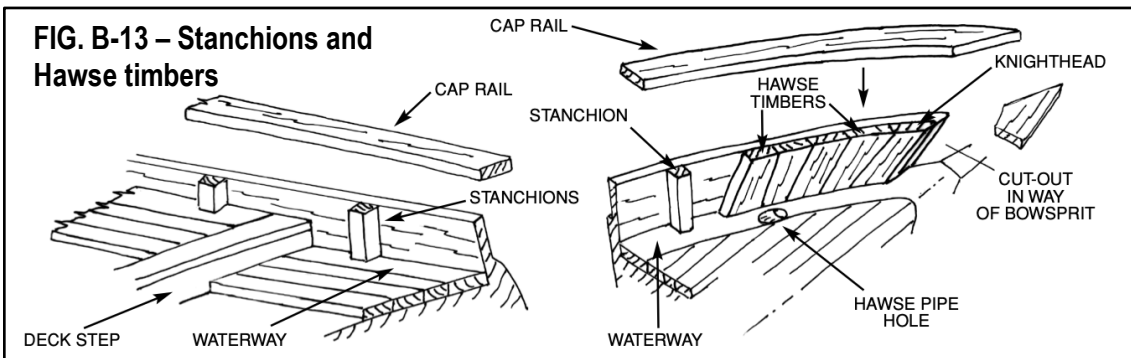

STAGE C: Mounting the Hull

Before proceeding with additional work it is best to mount the hull. This step will help prevent details from becoming damaged during handling and will allow you to make any alignments that require a true waterline. Proper mounting of the hull is very important and will allow the accurate building and aligning of the remainder of the model. The following mounting is suggested.

Mounting Board with Two Pedestals - A common mounting for ship models is a wooden baseboard with two wooden or brass pedestals. For a homemade board, a nice-looking hardwood such as cherry, walnut, and maple would be ideal. You can round the top edges of the baseboard or cut a simple chamfer. If you own a router, or can borrow one, you will be able to cut a nice fancy edge on the baseboard. Stain the base if necessary and give it a few coats of varnish or finish like Minwax. The pedestals could be wood or brass. One pedestal needs to be longer than the other because you should have the model mounted with the waterline parallel to the baseboard. If you decide on this type mounting, you should already have drilled pilot holes for the screws as noted earlier. For America, the pedestals should be located near bulkheads F and I. If something went awry and the waterline is not level, you can add a brass shim under one pedestal to correct it. No parts are included in the kit for this particular mounting, but baseboards and pedestals are available from Model Shipways web site, www.modelshipways.com.

Launching Ways - Launching ways provide another mounting method that has been used for many Model Shipway kits. Most appropriate for model without sails. Fig. C-1 is a suggested assembly and basswood strips are included in the kit for the construction. There are a number of ways this mounting can be configured, so feel free to design your own layout. Look at photos of actual shipyard ways for ideas. Stain the basswood to look like weathered wood or use a more finished looking stain. Adjust the mounting as necessary so the models load waterline (and the hull bottom paint line) is parallel with the baseboard. The upper support timbers shown in the generic sketch need to be modified to fit against the America keel.

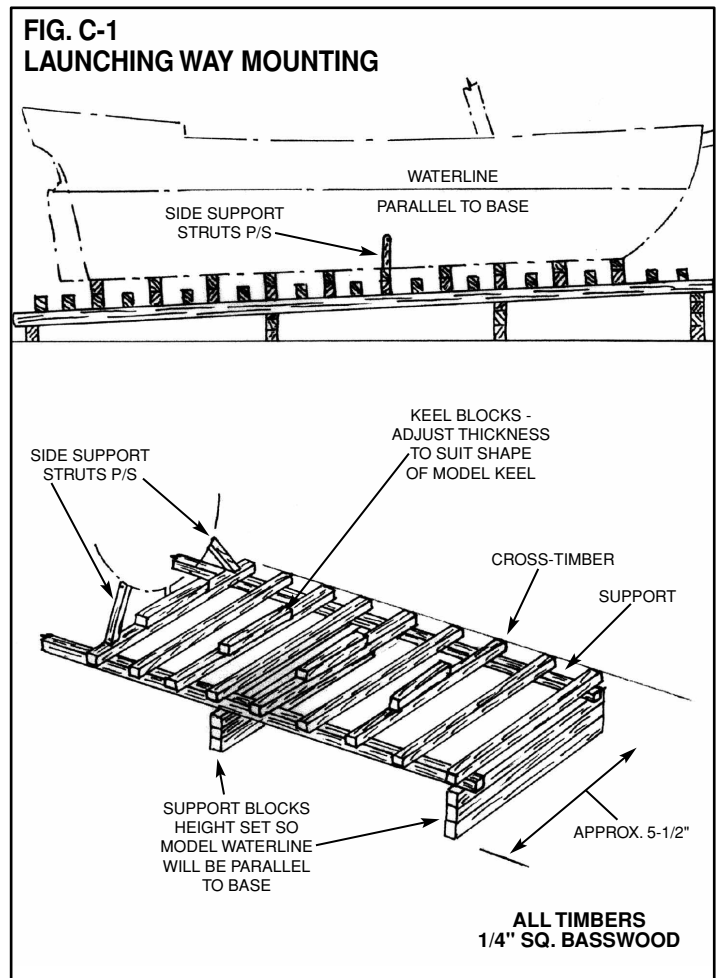

STAGE D: Adding the Hull Details

1. General Notes

Don't forget to file off any flash on Britannia metal fittings, clean the fittings and then prime them with grey primer before final paint. Mark the positions of fittings and structures. Drill holes if required for the fittings or for locating pins or dowels. Before permanent installation, paint the parts according America color scheme. If wooden parts are not painted prior to installation, at least make sure you have the part sanded and ready for painting

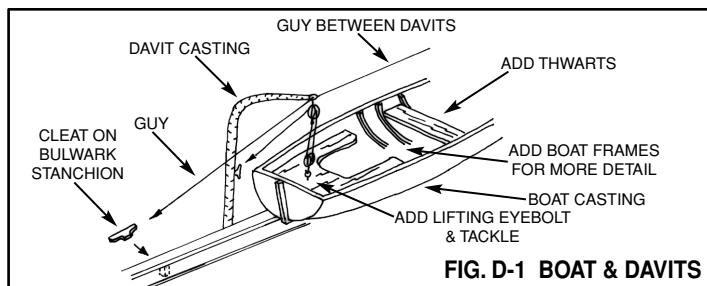

in place. Use as little glue as necessary on parts. Watch out for that glue squeeze-out. It's hard to remove if left to harden.

2. Completing the Bulwark Details

Before installing anything on the deck, complete all the remaining details on or near the bulwarks while there are no obstacles to contend with.

Hinged washports (also called freeing ports) - There are two rectangular openings (port and starboard) as shown on the inboard profile. Cut the openings, then fit with panel, hinged at the top outboard. On the real ship, the panel would freely open and release water that accumulates on the deck. As a model option you can just scribe lines to represent the port.

Scuppers - Two scuppers are shown on the plans, port and starboard. Simply drill a small hole in the bulwark at deck level. Note that the aft hole is right at the midship deck step on the lower deck level.

Cleats - Cleats are Britannia castings. Install on the bulwark stanchions in locations shown on the inboard profile.

Mooring Kevels - There is a kevel for belaying mooring lines on both sides secured to the bulwark stanchions. Make from stripwood.

Portable anchor davits - The anchor davits are Britannia castings. Even though they are portable, suggest installing them for added model detail.

Boat and portable boat davits - The boat davits are also portable. Boats were generally lashed down on deck. However, if you wish to install the boat provided in the kit on davits, install the davits either port or starboard. Complete the boat construction, adding the thwarts, and painting before installing. For added detail, insert wood or paper strips in the boat to represent frames. Rig

the davits with a tackle composed of 1/8" single blocks. Place eyebolts in the boat for securing the tackle (Fig. D-1).

Hawse pipe lips - Install the Britannia cast lips port and starboard on the outboard and inboard side of the hawse pipe holes.

Boom sheet horse and eyebolts - Make the boom sheet horse

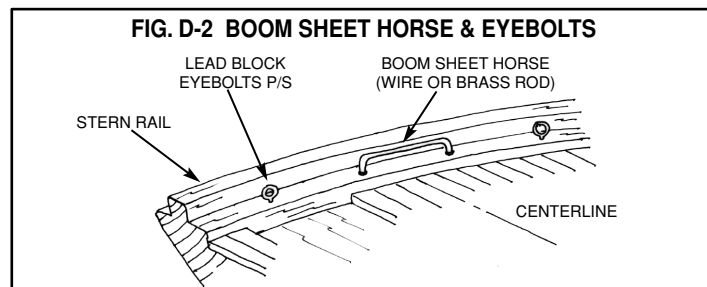

from the wire supplied in the kit (Fig. D-2).

Sponson for fore shroud chain plates - Carve the sponson (or call it a channel) from basswood and install on the outside of the bulwark port and starboard. The top is at the sheer line (Fig. D-

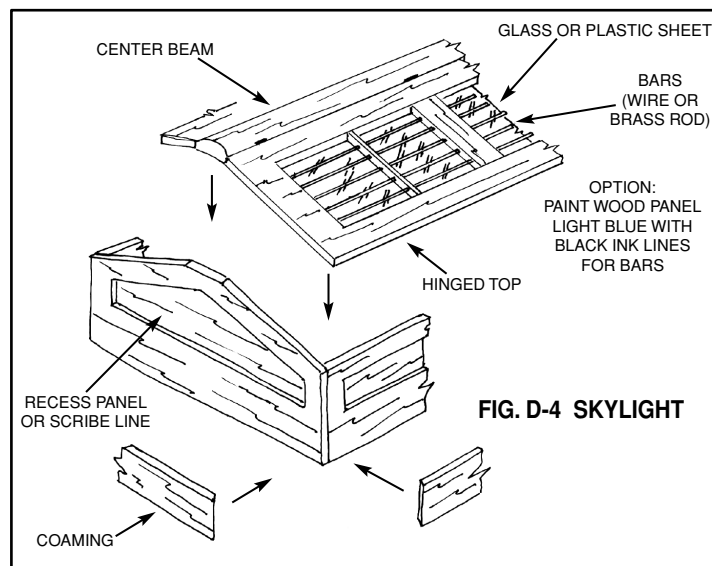
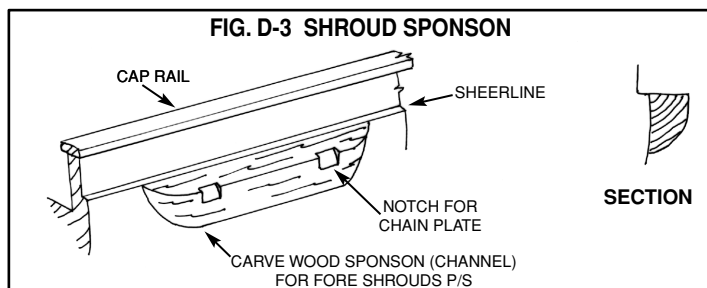

3).

3. Constructing the Skylight (aft)

Fig. D-4 illustrates a method for constructing the skylight, using laser cut basswood parts. For the glass and bars, at such a small

scale, the easiest approach is to glue pieces of plastic sheet under the frames, and add inked details as desired. But go for it if you want real detail.

4. Constructing the Companionway

Fig. shows the recommended construction using laser cut basswood parts. Pieces of solid basswood sheet or transparent plastic can be glued to the inside surfaces to cover the openings. Also, you do not need a cutout on the top if the sliding top is closed.

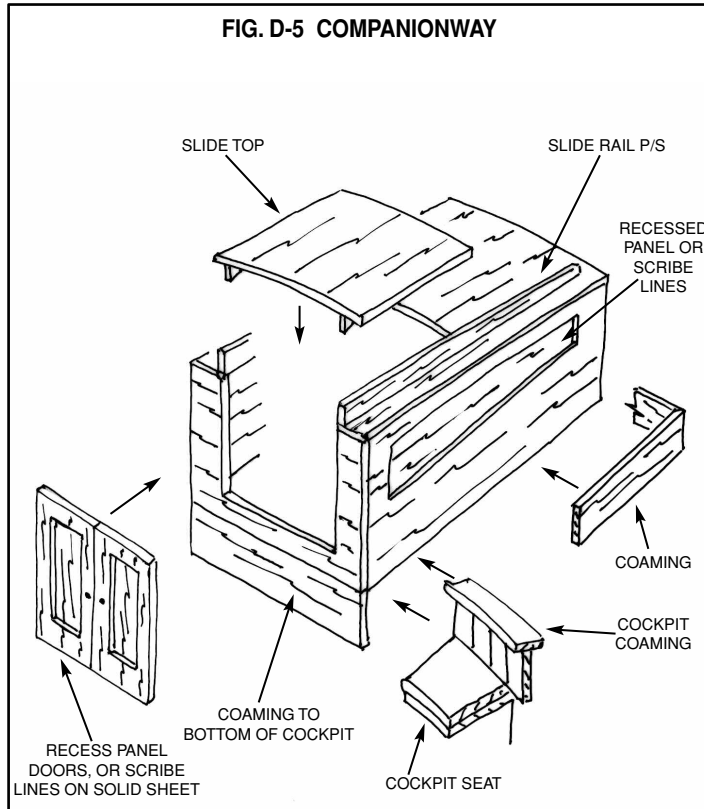

5. Installing Britannia Castings

Forward round skylight and capstan - Paint the castings before installation. If necessary, file the bottom of the castings to the deck camber, or sand down the deck in way of the castings so they sit flush on the deck.

Windlass/bowsprit bitts - The rocker arm is a separate casting. Glue it to the bitts before installation. Insert a piece of wire between each end of the rocker arm and the ratchet arm. Option: You can install the bitts and windlass now or wait and install the casting and the bowsprit at one time. If done now, it would be a good idea to drill a hole in the bottom of each bitt and into the deck for a wire positioning pin or a dowel.

Deck cleats - Glue the cleat castings in locations shown on the deck plan. For added security drill a hole thru the casting and fix with a nail or pin.

Galley stack - The galley stack is located to port of the Forward Hatch as shown on the plan. Drill a hole in the deck and glue in the casting.

Anchors - Fit the anchor chain to the anchors, then lash the anchors on the bulwarks as shown on the plans. The castings provided have the stock folded along the anchor shank. If you desire to have the stock in place like the plan illustrates you will need to cut off the stock and make a new one from brass wire.

Stern eagle and bow trailboards - Paint the castings before installation, then glue in place. For added security drill holes thru the castings and fix with a nail or pin.

6. Remaining Deck Fittings

Forward Hatch – trim the supplied walnut grating to approx. 1-1/6" x 11/16". Make a "frame" of 1/16" x 1/8" strip wood around the edges, make a coaming box for the hatch to sit on and glue the assembly to the deck as shown on the plans.

Rigging Eyebolts - Install the rigging eyebolts in locations shown on the deck plan. As an option you can fix the blocks to the eyebolt and install all at once.

Deck plate for pump - This is a screw plate in the pump pipe and is located just to port of the main mast. An actual pump is stowed and is not provided in the kit. The screw plate can be represented by using a round piece of self-adhesive copper tape, or just a dab of copper paint.

STAGE E: General Mastng and Rigging Information

1. Rigging Identification

All of the rigging is identified by name on the rigging plan. If you are not familiar with the names and functions of rigging lines, the book *How to Build First-Rate Ship Models From Kits* by Ben Lankford contains a description of Nautical terms (See Bibliography).

2. Block, Deadeye, Bullseye, and Line Sizes

The kit includes enough blocks, deadeyes, bullseyes, and rigging line for rigging America with or without a full set of sails. Since the rigging sizes are not noted on the plans, the following identifies the appropriate sizes provided to use for the various rigs:

3. Standing Rigging

1. Forestay - 0.040" dia. black line for the stay and bridal at the top. Under the bowsprit, use a 5/32" double block and bullseye with 0.012" dia. black line lanyard.
2. Main topmast stay - 0.021" dia. black line.
3. Triatic stay - 0.028" dia. black line.
4. Main boom topping lift - For the pendant use 0.028" dia. black line. For the Tackle at aft end use 1/8" single block with 0.012" tan line.
5. Main boom footropes - 0.028" dia. black line.
6. Fore and main shrouds - 0.028" dia. black line with 5/32" dia. deadeyes. Use 0.012" dia. black line lanyards.
7. Bobstay - For the pendant use 0.040" dia. black line. For the tackle at the forward end, use 5/32" single and double blocks with 0.018" dia. tan line.
8. Bowsprit shrouds - 0.021" dia. black line, set up with 1/8" dia. bullseyes and 0.012" dia. black line lanyard.

4. Running Rigging

1. Jib Halliards & Downhaul - 1/8" single blocks with 0.012" dia. tan line.
Sheets (port and starboard) - 1/8" single blocks with 0.012" dia. tan line.
2. Foresail
Peak halliards - 5/32" single blocks and 3/16" triple block with 0.018" dia. tan line. The triple block is a little too big but no 5/32" blocks are available. You can file it down to length or just use as-is.
Throat halliards - 5/32" single and double blocks with 0.018" dia. tan line.
Sheets (port and starboard) - 5/32" single blocks with 0.018" dia. tan line.
3. Mainsail
Peak and Throat halliards - Same sizes as Foresail.
Boom sheet - 3/16" triple, and 5/32" single and double blocks with 0.018" dia. tan line. As with the peak halliards, the 3/16" triple block can be filed down to 5/32".
Reef Pendant - 0.012" dia. tan line. There are no blocks.
Signal Halliards - 1/8" single block with 0.005" tan line (from polyester spool).
4. Main Gaff Topsail
Halliards, Downhaul, and Sheet - 1/8" single blocks with 0.012"

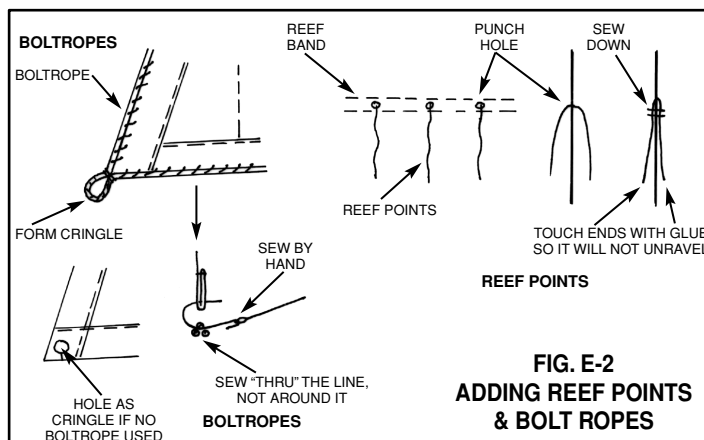

dia. tan line.

Flag Halliard at Topmast - 0.005" dia. tan line (polyester). You could use a 1/8" single block but more common, the halliard reeves thru a sheave hole in the topmast ball.

5. Sails and Sail Lines

Model with Sails - The plans for this model include a full open set of sails, but you have the option of building the model with sails furled, partially furled, or with no sails. Most of the rigging text and detail sketches provided in the instructions will be addressing the model without sails. The following provides some typical model procedures if you prefer to add sails. The discussion and figures are general in nature and include yard sails not applicable to America. However, the procedures are basically the same for any type of sail. Follow the plans for the specifics on each sail.

Making a model sail (Fig. E-1) - Choosing the proper material is critical. Sailcloth for models must be lightweight, yet fairly opaque. Although linen is ideal, most is too heavy for small scale models, so select tightly woven cotton fabric. Wash the sailcloth several times to pre-shrink it. When dry, iron the fabric, but be careful not to scorch it. Lightly pencil in seams, tabling (hem) lines, and other reinforcements, then sew the seams using light tan cotton thread. A sewing machine makes fast work of the project. Practice on scrap fabric and balance the needle thread tension so it doesn't pucker the material. Stitch lines to represent reinforcement patches. Before proceeding, iron the sails again and be careful not to scorch them. Next, cut the sail shape using Line A shown in the sketch. Fold the hem, iron it flat, and sew as close to Line B as possible. Tuck the ends and hand stitch the comers. The sail is now ready for stretching. Stretching the material assures the sail's proper shape, since sewing may have altered it. Using the original pattern, trace the sail's outline onto a piece of paper. Place the paper on a solid but porous backing, such as a wood or cork board. Now wash the sail again and lay it over the outline. Stretch the wet material to the sail's outline's, then secure with stick pins through its outer edges. When dry, the sail will have resumed its proper shape. Iron it one more time.

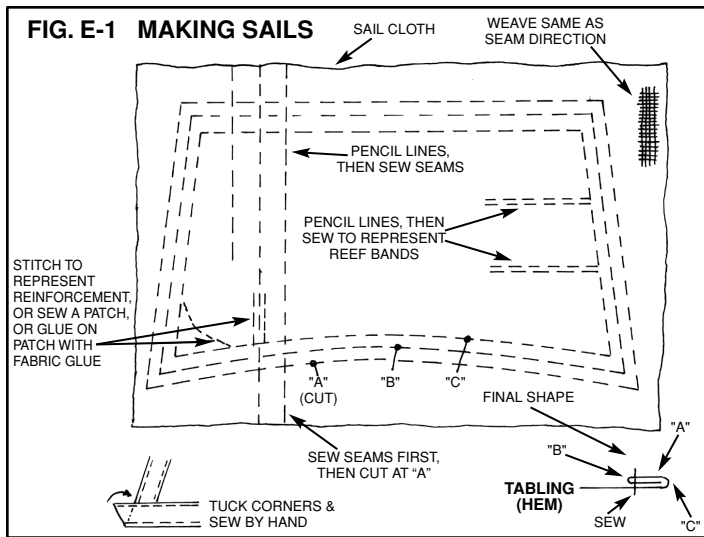

Boltropes and Reef Points (Fig. E-2) - Although boltropes (rope sewed to the edge of a sail to give it strength and prevent the fabric from ripping) can be omitted on small scale models, they add immeasurably to larger ones. The sketch shows the correct way to sew boltropes and install reef points.

Sewing Aids - Visit a fabric shop and purchase a squeeze bottle of Fray-Check, a light adhesive. Running or brushing a bead along the edge of a sail prevents the material from unraveling. Do this before attempting to roll the hem. Painting Fray-Check on untreated fabric makes cutting easier and produces a crisp edge. Stitch Witchery and Wonder-Under are heat-fusing bonding tapes that resemble thin mat fiberglass. Stitch Witchery comes in a roll and is bond-sensitive on both sides. To join two clothes, simply place a strip between them and iron. Wonder-Under comes in sheets with a thin paper backing on one side. While not needed for America, it is useful for bonding letters and numbers to a scale sailboat's sail (maybe one of your future models). First, buy the colored fabric for the numbers. Place the Wonder-Under sheet on the cloth with the paper backing up. Iron the sheet to bond it to the fabric. Next, cut out the letters, numbers, logo, or whatever with scissors or a sharp blade. Peel off the paper backing, position the letter on the sail, and iron. This technique also works for making flags from colored fabric.

Material for Furling Sails - A sail cut to the original's scale size is impossible to furl. The fabric is usually too heavy, resulting in a bulky furlled sail. To solve this problem, either buy a lighter material such as Silkspan (model airplane covering tissue) or proportionally reduce the size of a sail by one-third when using sailcloth (Fig. E-3). Depending on their size, even Silkspan sails may require reducing by one-third. Test the percentage reduction to determine how much fabric is needed for a tight furl. Don't forget to add some seams and hems, for these details are visible even on furlled sails.

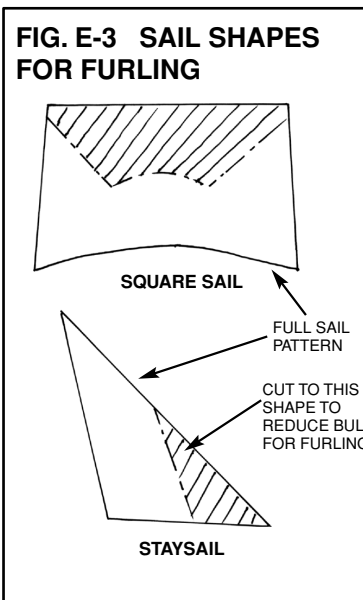

Model without sails - Even without sails, some of the rigging lines such as sheets, halliards, and clew lines are to remain, along with their lead blocks. Some of the lines are to be hooked together, such as head staysail halliards and sheets, and yard clew lines and sheets. The hauling ends of these lines should be belayed at their proper locations. Installing these sail rigging lines on the model adds tremendously to the look of the model, especially at the stays where the contrasting black stay and light running lines, along with their blocks, create interesting visual detail.

Furled and Partially Furled Sails (Fig. E-4) - Sails are often left partially furled, perhaps for drying the sail. This is a practice especially suited to square sails, with the sail pulled up with their clew lines and bunt lines. The sketch illustrates some of furled and partially furled sails. Note: Model Shipways has silkspan and a balooner cotton sail cloth. Check their web site. The balooner cloth may be a little heavy for this model. A lighter cotton cloth would be a better choice.

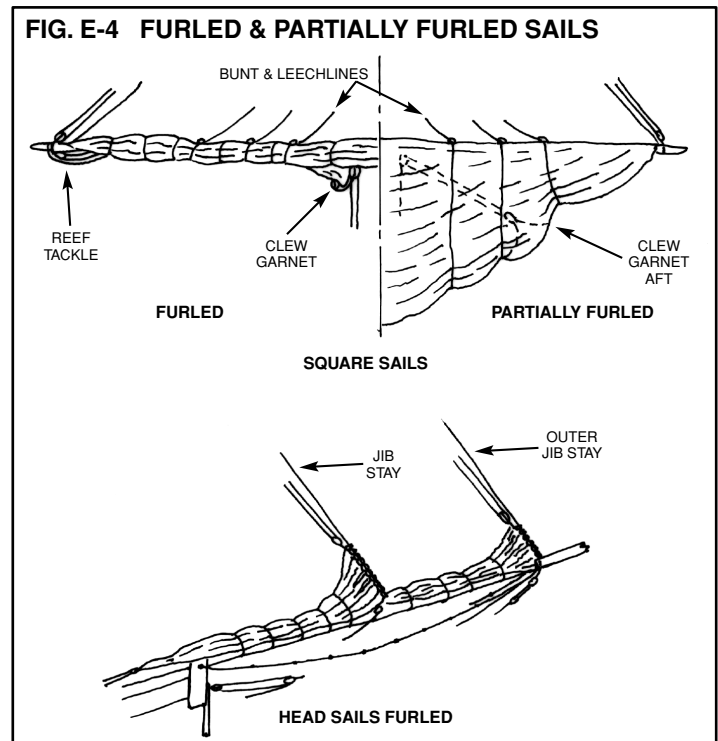

6. Applying Beeswax to the Lines

Before placing rigging lines on the model, run the line through a block of beeswax several times. Then, run the line through your fingers. This heats the wax slightly and rubs it into the line. The beeswax will cut down on fuzz and protect the line from

moisture.

7. Seizing Rigging Lines

Seizing of lines (binding or securing two lines or different parts of the same line) can be done as shown in Fig. E-5. To prevent seizings from unraveling, add a touch of CA glue. For seizings, use the smallest line in the kit or sewing thread.

8. Fittings & Block Strops

Making Fittings - America kit includes several Britannia castings for such items as mast and bowsprit cap bands. Other fittings must be made from scratch. Brass is a preferred material for these fittings, which may or may not require soldering, but there are other options that can be considered. Fig. E-6 illustrates some modeling ideas for fittings found around such items as masts, booms, gaffs, and bowsprits. Note that brass strip, self-adhesive copper tape, and eyebolts are provided in the kit. Sufficient quantities are supplied no matter which method you choose for your fittings.

Block Strops - A strop is an iron or rope band or grommet around the shell of a block for attaching lines. The blocks in the kit are fairly small

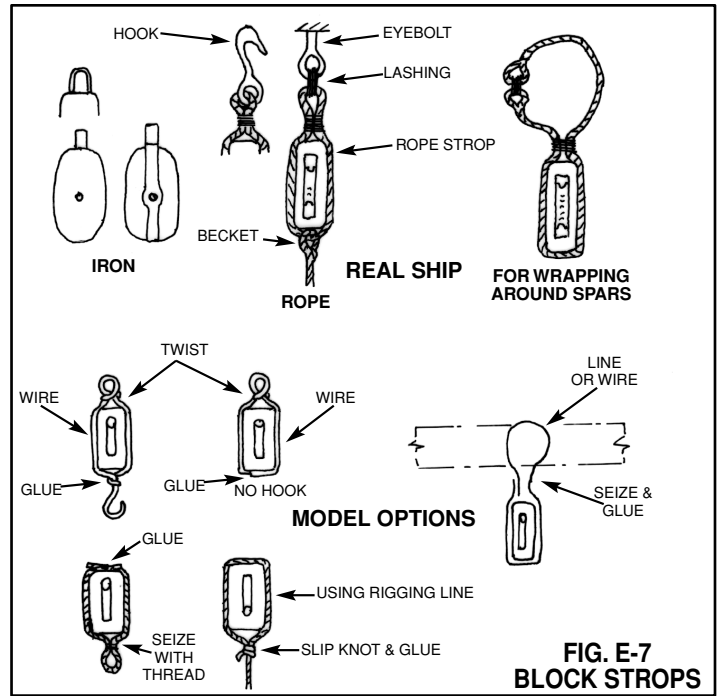
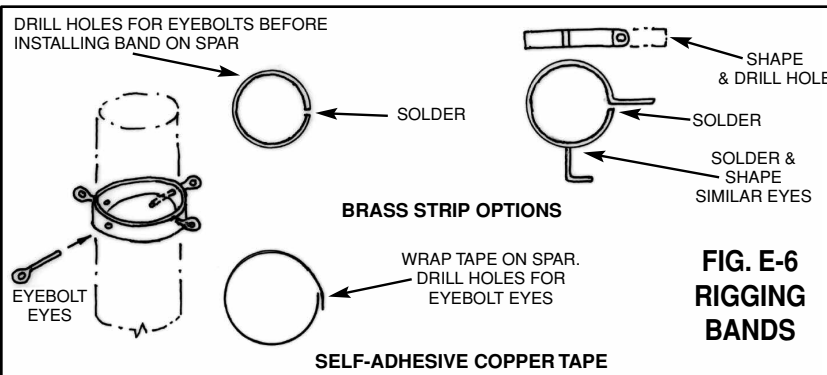
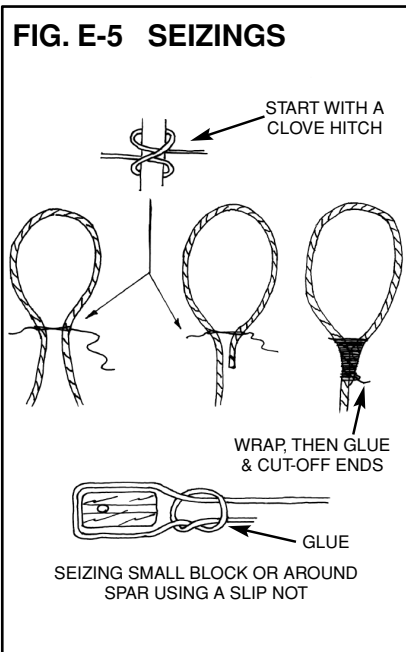

so it will not be easy for you to create the exact detailing. Some modeling shortcuts are in order. See Fig. E-7 for some life-size ship details and model options.

9. Rigging Tools & Belaying Lines

The belaying pins in the kit are a little oversize since they are the smallest pins available. They could be cut to a shorter length or just left as is. To aid the rigging process homemade tools can be made from brass rod with a push fork end or a hook end (Fig. E-8). Use a brass rod long enough to reach in where your hand cannot. Such tools are also available commercially. When belaying lines on small scale models it is best to secure the line to pins or cleats first. Then add a coil of line on the belaying point separately. See Fig. E-9.

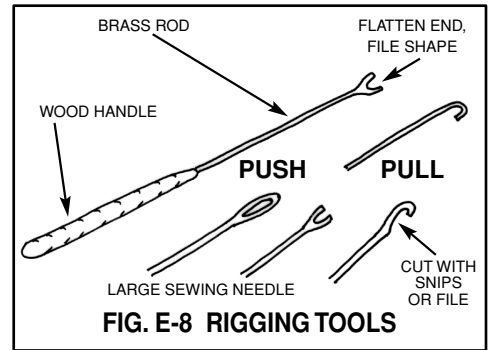

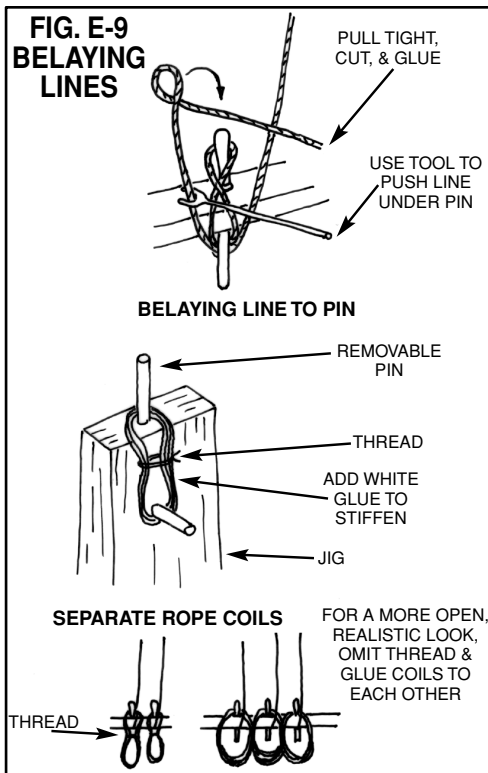

STAGE F: Mast & Spar Construction

Most references call a mast a mast, and anything else such as a boom, yard, gaff, and bowsprit a spar. Let's stick with that definition. Except for the bowsprit, the mast and spar dowels included in the kit are round. True to scale, masts and spars must be tapered for their full length.

1. Shaping the Masts & Spars

Quality dowels are provided for the mast and booms. The best way to taper is by hand using a sharp #11 hobby knife blade in conjunction with sandpaper and sanding block and slowly working back and forth with them. It is much better to use small short cuts with the blade so as not to gouge the dowel. Also due to wood grain there is an easy way to cut and a harder way to cut down the length of the dowel. When starting to cut and it is difficult with gouging turn the dowel end for end. Do this as a test before cutting dowels to length for a part. A dowel can also be tapered by chucking it into an electric drill and as the speed of the drill turns the dowel, use sandpaper to shape and taper.

The correct shape of the masts and spars are shown on the plans. Each of the mast and spars are generally tapered in a slight (parabolic) curve. However, for models, it may be difficult to accomplish a parabolic shape. A straight-line taper should be sufficient.

Shaping the Mastheads - Main topmast - The main topmast has a rigging stop where the topmast stay secures. A rigging stop is simply a shoulder formed by the reduction of the mast diameter going above. The shoulder prevents the lines from sliding down

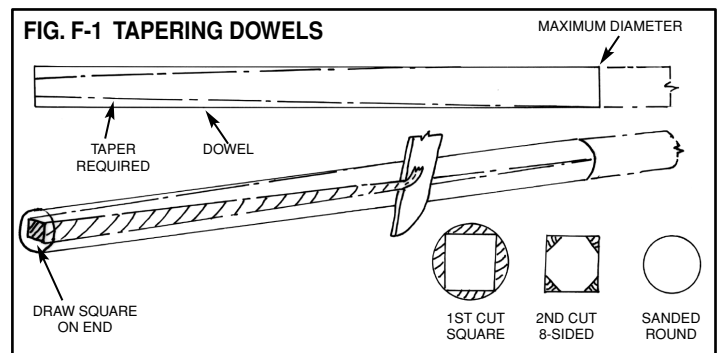

the mast. For the model, to actually cut the shoulders could weaken the mast and it could break. Instead, as an option, wrap the mast with thread or paper strip and glue to form a fake shoulder (Fig. F-2). Also, the heel of the topmast has a fid that prevents the mast from sliding thru the band.

Fore and main mast - The mastheads must be reduced in diameter and shaped to fit the Britannia band castings (Fig. F-3).

2. Assembling the Masts

The mast caps, and the lower bands where the shrouds are located are Britannia castings. Add the fittings, then assemble the mainmast and topmast. Make sure the mainmast and topmast are parallel (Fig. F-4).

Mast Details - Before painting and staining the masts there are a few details to add. Add the eyebolt for the gaff peak halliard block on both the fore and main masts. Install the boom rest/spider band on the mainmast. Fit the belaying pins in the spider band. On the foremast add the rigging cleats on the mast just above deck level. You can also add the various halliard blocks at the masthead; easier with the masts in hand.

provided in the kit. A tenon is required on the forward end of the bowsprit to fit the bowsprit cap casting. A slight notch may be required on each side of the heel so the bowsprit will fit in the bowsprit bitt casting on deck.

Assembly and Installation - The bowsprit cap casting is an identical casting to the fore masthead cap. However, the casting

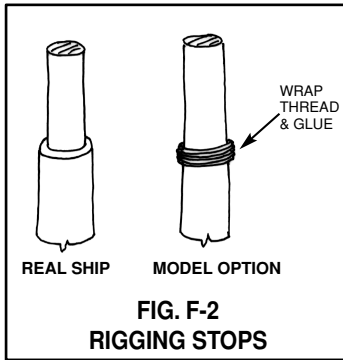

Fore and Main Sail Mast Hoops - These need to be put on the masts before installing the mast head fittings if you elect to include them. Refer to Stage H for a discussion on the hoops.

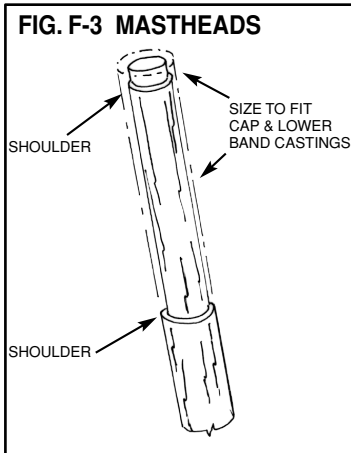
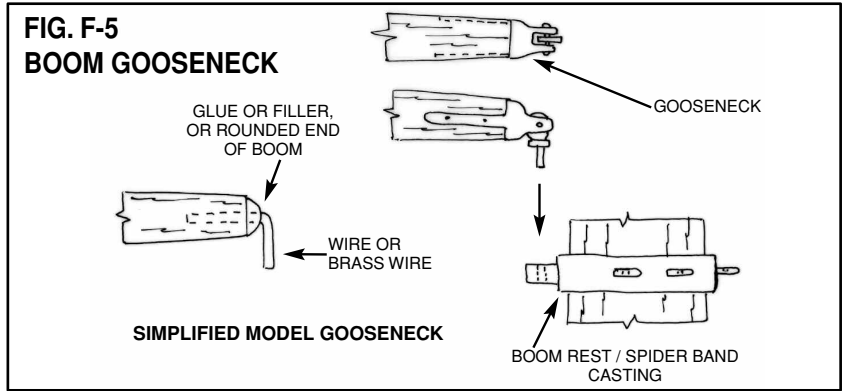

3. Shaping & Detailing the Spars

Boom & Gaffs - The main boom and fore and main gaff also taper, but the maximum diameter of each spar should be about one-third from its fore end. There is a shoulder at the outer ends of these spars. Cut the shoulders per the plan.

needs to be modified for the bowsprit. Cut off the top eye. Drill holes on each side and insert eyebolts to form two side eyes. As an option, replace the fitting with brass strip or self-adhesive copper tape for the band, then drill holes and insert three eyebolts to form the eyes. Add an eyebolt for the jib downhaul block and drill a hole for the forestay to pass thru. Add the rigging cleats on the bowsprit. After installing the bowsprit add the gammon iron made from brass strip or self-adhesive copper strip. Fig. F-7 provides some bowsprit details.

4. Installing the Masts

Install the masts in the holes drilled into the deck. Check the alignment fore and aft for correct rake and for vertical alignment looking aft and shim if necessary. When set, add the mast coats. The mast coats are actually canvas covers over the wedges on a real ship holding the masts in place. For the model, mast coat halves are laser-cut parts #16. Shape and add these at the deck around the masts.

Boom - Add all the boom fittings such as the boom sheet block and chock, stop chocks, rigging cleats, reef pendant cleats, and the gooseneck at the fore end. The gooseneck pin will fit into the boom rest fitting. Fig. F-5 shows a detail of the gooseneck and a model simplification.

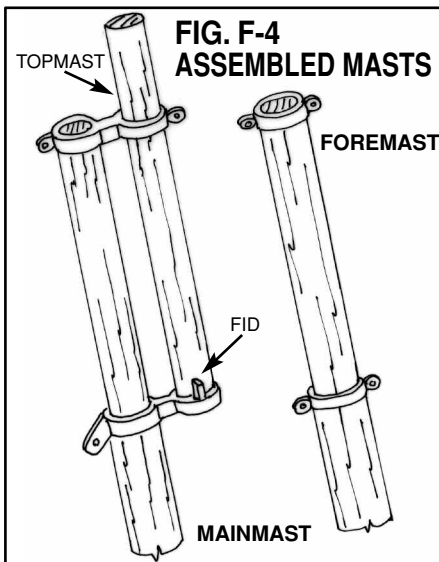

Gaffs - Jaws with a parrel must be added to the gaffs for joining to the masts. The jaws are laser-cut wood parts for this kit (Fig. F-6). The plan shows beads on the parrel line but these could be omitted on the model. Also, add the stop chocks for the peak halliard blocks and the eyebolts for the throat halliard.

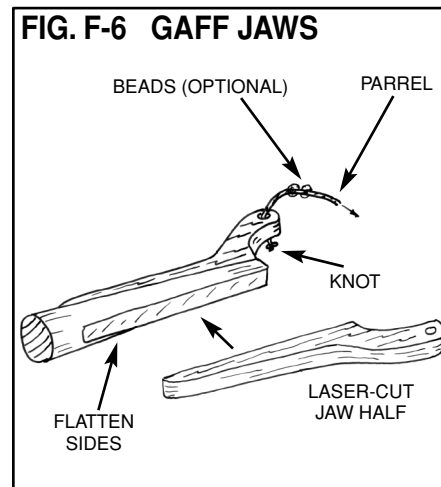

Bowsprit - The bowsprit is square from the heel to just beyond the bow, then round. It is easier to start with a square piece and shape the rounded portion. Consequently, a square basswood strip is

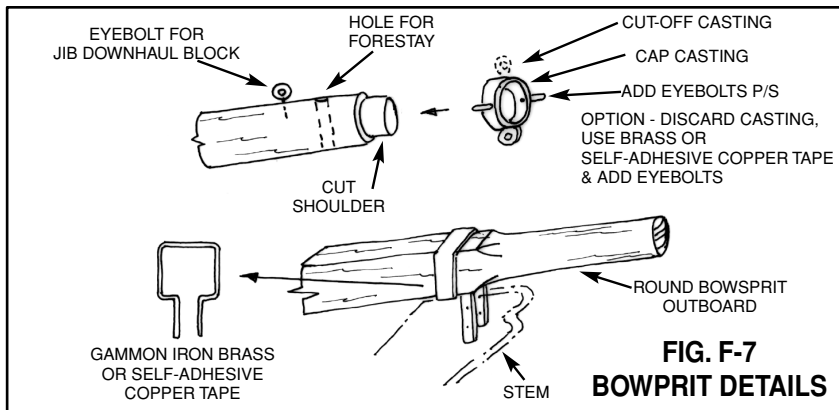

STAGE G: Standing Rigging

1. Forestay

The forestay passes thru the hole in the bowsprit, then sets up with a tackle for tightening the stay. The tackle is attached to a rod which in turn is bolted to a fitting on the stem. Topside, the stay is fitted with a bridle which has a turnbuckle for further fine

tightening. Fig. G-1 illustrates the rig.

2. Main Topmast Stay and Triatic Stay

These two stays have eye splices in each end. The top of the topmast stay fits over the mast at the rigging stop. The other ends of the stays are fixed with shackles to the eyes of the mast castings. For the model, shackles can be omitted and the line seized to the fitting eyes.

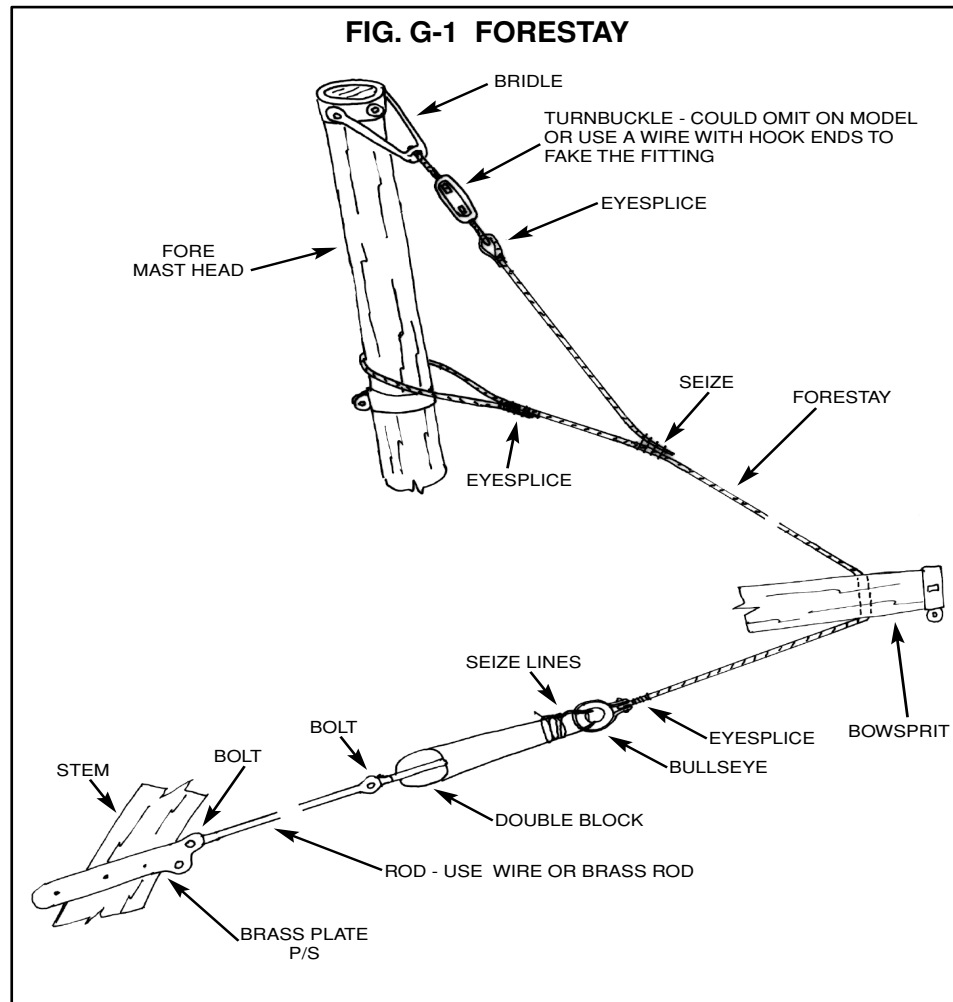

3. Bobstay

The bobstay attaches to the lower eye of the bowsprit cap. At the cap there is a tackle and the pendant portion bolts to the fitting at the stem (same fitting used for the forestay). The fall of the tackle belays to a cleat inboard on the bowsprit. (Fig. G 2.)

4. Bowsprit Shrouds

The bowsprit shrouds set up to bullseyes and lanyards at the hull. Add an eyebolt port and starboard. At the fore end the shrouds set to the side eyes of the bowsprit cap fitting.

5. Fore & Main Shrouds

The shrouds are set up with deadeyes and lanyards at the hull and attached along the outside of the ship using chain plates. The fore shroud chain plates pass over a small wooden sponson or channel so the shrouds will clear the bulwark. Make the sponson from stripwood. A sponson is not necessary for the main shrouds as the hull side projects far enough beyond the bulwark.

The deadeye strops and chain plates are to be made of wire provided in the kit (Fig. G-3). To set up the shrouds, make a temporary jig of wire to space the deadeyes as you do the seizings (Fig. G-4). The sketch also shows the sequence for reeving the lanyards. Keep an eye on the masts as you rig the shrouds, so you will not pull them out of line. After the shrouds are in place, add the sheer poles. This is simply a brass rod or wire seized just above the deadeyes.

6. Boom Footrope & Topping Lift

These lines and fittings are actually a part of the standing rigging but we will defer the instruction to running rigging, Stage H. These rigs are best installed along with some running rigging while working with the spars.

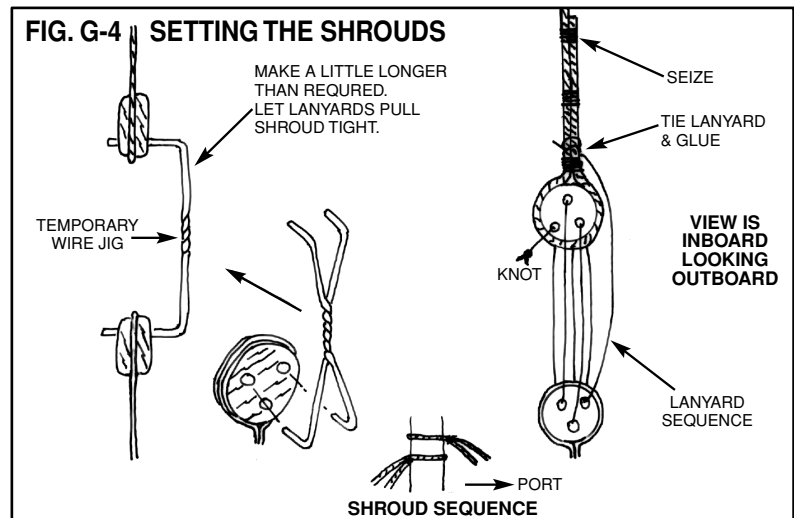
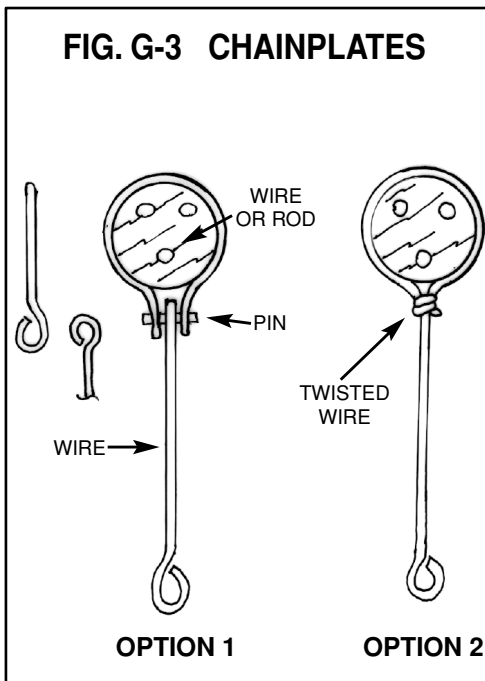
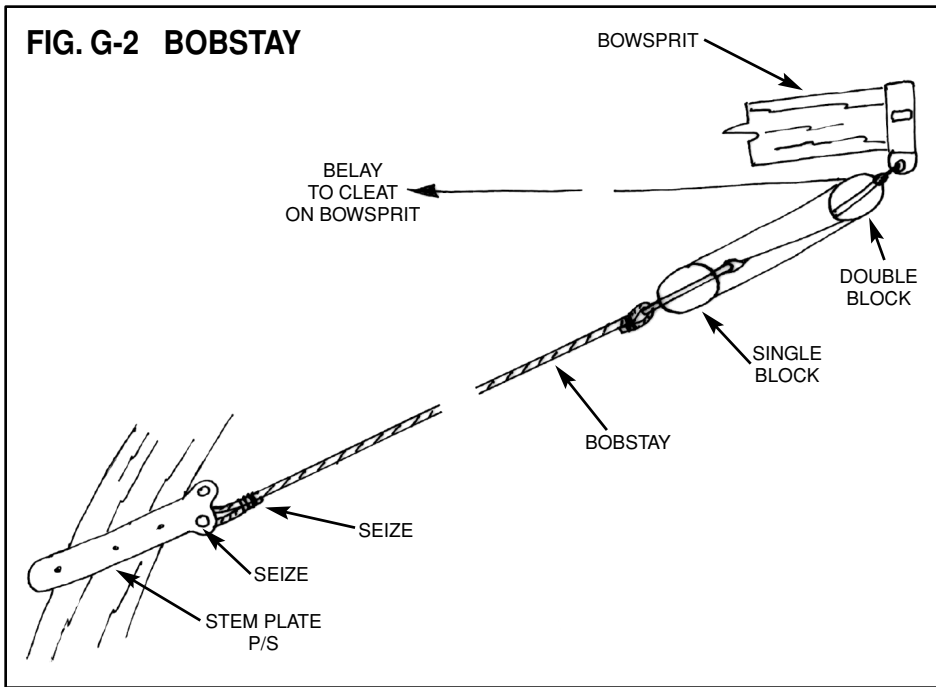

STAGE H: Running Rigging

Before starting on the running rigging, have all your blocks stropped and/or seized to a line as much as possible. As noted in Stage E, the instructions concentrate primarily on a rig without sails. However, if you intend to install sails, either full-up or furled, refer back to Stage E for some of the suggested details.

Mast Hoops - You were advised earlier to add mast hoops on the fore and main mast before they were installed. However, these are not supplied in the kit. Make your own from wood, paper, or use some brass rings. To make wood or paper hoops, laminate about 3 layers of paper or wood shavings over a dowel covered with wax paper to prevent sticking. Cut the hoops to width. Model Shipways also has some nice laser-cut mast hoops you can purchase separately.

1. Jib (fore staysail)

The jib has a halliard, downhaul, tack, and port and starboard sheets which are attached to a jib club boom at the foot of the sail. With sails removed or furled the jib club can remain in place but you need some means to support the aft end of the boom. The plans do not indicate how this is done. You could place a temporary wooden crutch under the boom or rig a line from the end of the boom, thru a single block topside and down to a cleat on the mast. With sails removed, the halliard and downhaul can remain hooked together. Place the hook point just above the downhaul block which is seized to the eyebolt in the bowsprit. The downhaul bays to the bowsprit bitts inboard. Topside, the halliard feeds thru a single block seized on the forward eye of the lower casting. The halliard then goes to the deck and is belayed

to a cleat on the Fig. H-1 illustrates the jib rig.

2. Foresail

Sheets - The foresail is loose footed (no boom). With the sail removed the sheets can be omitted, being removed with the sail. For a furled sail the gaff is lowered and the sail bundled under the gaff. In this case the sheets would remain in place.

Gaff Throat and Peak Halliards - Rig the halliards per the plan. The peak halliard fall goes down on the starboard side and bays to a starboard cleat on the mast after passing thru a lead block set to an eyebolt on deck next to the mast. The throat halliard fall is similar except it goes down on the port side. Note: With the sail removed, the gaff should be in a lowered position. However, many model builders prefer to have the gaff in a raised position to help fill the open space between masts. Your choice, but if in a raised position you will need to fix the gaff jaws at the mast so the gaff does not flop sideways. Fig. H 2 illustrates the rig.

3. Mainsail

Gaff Throat and Peak Halliards - The rig is identical to the fore gaff except reverse the run of the halliards; peak to port side and throat to starboard. Refer to the note under foresail regarding placement of the gaff if no sail is installed.

Boom Topping Lift & Boom Sheet - Rig the topping lift first to position the boom, then the sheet to hold it down. The topping lift pendant is fixed to the aft eye on the mast cap casting. The

running tackle feeds thru a hole in the boom and bays to a cleat on the starboard side of the boom. The lower block for the boom sheet is set with a ring on the iron horse on centerline at the deck. The two hauling ends bay to cleats on deck port and starboard. See Fig. H-3 for topping lift and sheet details.

Boom Footrope - Use black line for the footrope. Knot the footrope as shown on the plan. The knots prevent foot slip. The plan does not clearly show where the forward end of the footrope ends but it appears to go to one of the boom cleats or could be seized around the boom at that point.

Reef Pendants - With the sail removed the reef pendant can be omitted.

Signal Halliard - The halliard reeves thru a single block on the gaff and bays to a boom cleat. With or without a sail the halliard can remain.

4. Main Gaff Topsail

Tack & Downhaul - With sails removed the tack and downhaul can be removed with the sail.

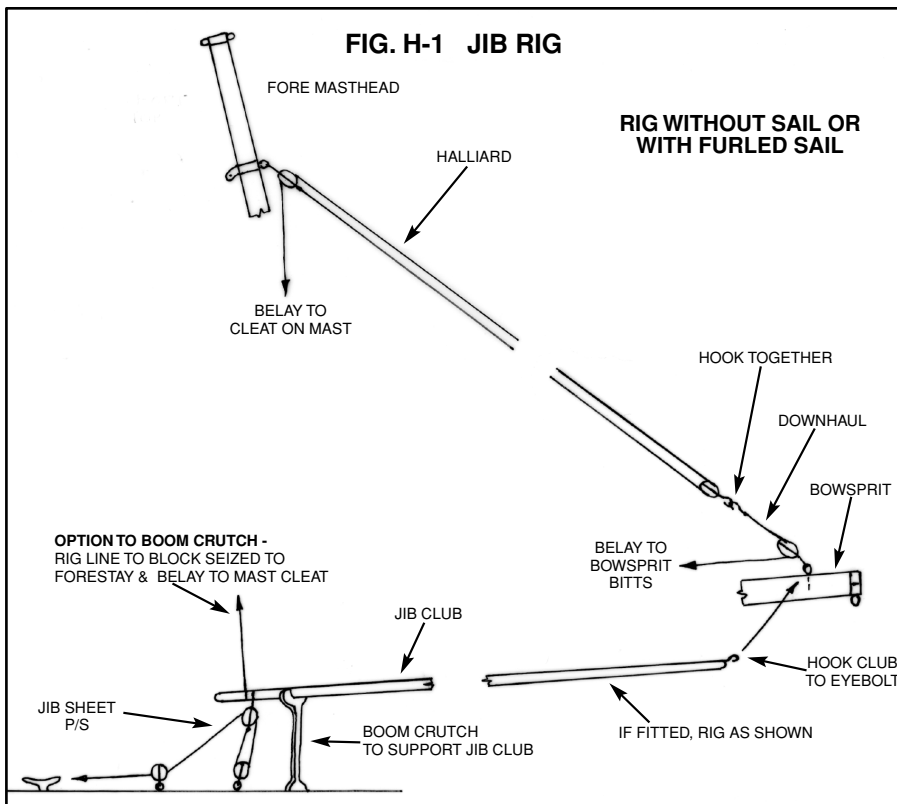

Sheet & Halliard - The sheet blocks and the line can still be rigged if there is no sail. Knot the sheet end that would normally be attached to the sail so it will not slip thru the block. Belay the running end from the block under the gaff to the spider band. The lower halliard block detached from the sail can be brought down and hooked to the eyebolt on top of the gaff (same eyebolt used for the throat halliard block) or it could be hooked to the spider band (Fig. H-4). If a furled sail is installed it would be furled against the topmast. The halliard would be attached to the top of the sail as usual and the sheet would also be attached. The sheet would most likely run from the block at end of the gaff to some location up the topmast, depending on how the sail is bunched for furling.

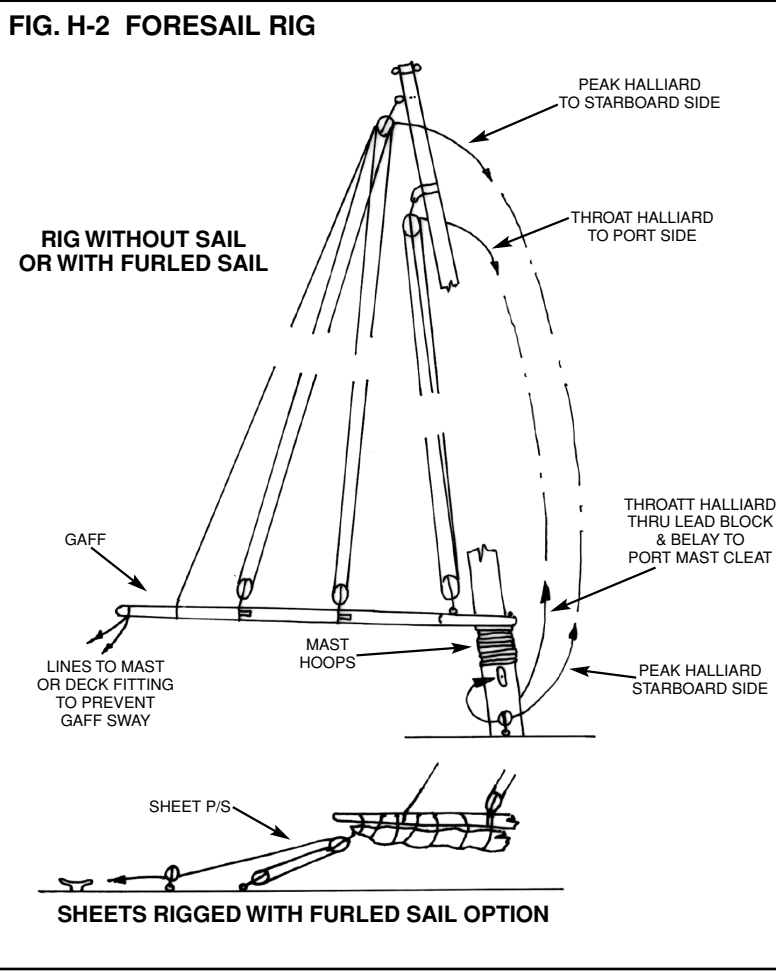
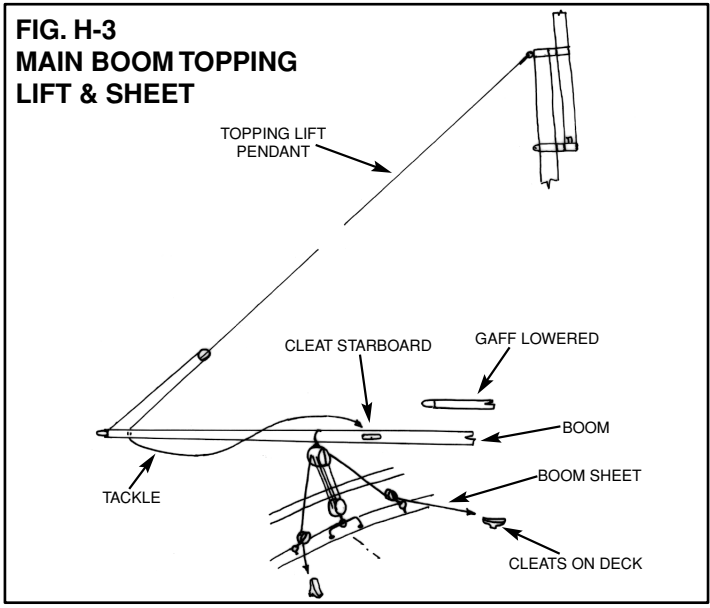

5. Final Touches

After all the rigging is in place, re-check every line, and make sure all the seizings are sound. If necessary, add another touch of CA glue to seizings. Check to see if there are any shiny places on the rigging. If necessary, tough-up standing rigging with black paint, or black liquid shoe polish. For running rigging, use a tan stain, or brown liquid shoe polish. Check to see if any of the painted wooden parts were marred or scratched during the rigging process and touch-up as necessary.

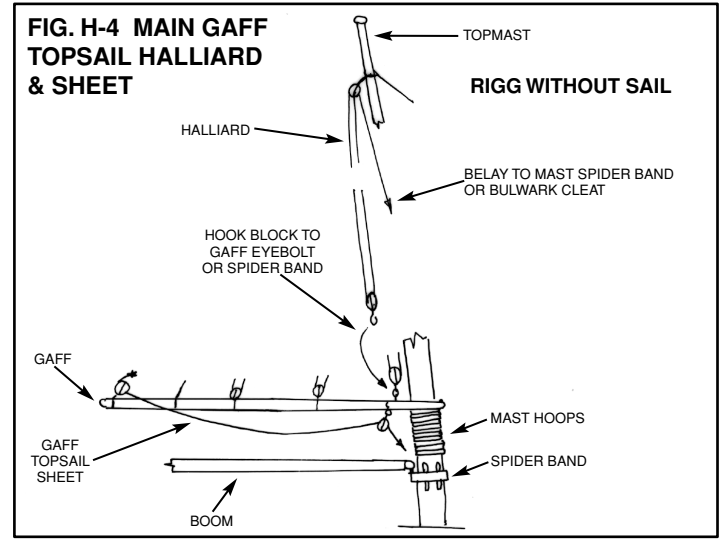

Bibliography

1. The Low Black Schooner: Yacht America, 1851-1945,

by John Rousmaniere.

Diane Pub Co., 1986.

Traces the development and racing success of the schooner and subsequent career. Book has color and B&W photos and three fold-out plans.

2. Mastng and Rigging the Clipper Ship & Ocean Carrier

by Harold A. Underhill.

Brown, Son and Ferguson, LTD, 1946.

An excellent reference for mastng and rigging details in the age of iron fittings.

3. Spars and Rigging: From Nautical Routine, 1849

By John M'Leod Murphy, W. N. Jeffreys.

Ship Model Society of Rhode Island, 1933 (Reprinted by Dover Publications 2003).

The Ship Model Society of Rhode Island reprinted in a limited edition the section on spars and rigging from Nautical Routine published in 1849 by Murphy and Jeffers, past midshipmen, U. S. N. It presents a detailed description of the spars, rigging, sails, and other gear of a full-rigged ship. In addition to his own experience at sea, Murphy consulted the most experienced riggers he could find in order to ensure that the book represented the state of the art in 1849. The result is a treatise of great value and reliability to anyone interested in understanding the rigging of a sailing vessel.

4. The Neophyte Shipmodeller's Jackstay

by George F. Campbell. Model Shipways, 1962, slightly revised 2007.

Excellent visuals and background information on building models from kits. Good detail on hulls and rigging. Great for beginners.

5. How to Build First-Rate Ship Models From Kits

by Ben Lankford, Model Expo 2002, slightly revised 2007.

Comprehensive reference covers construction methods for solid hull, plank- on-bulkhead, and plank-on-frame kits. The book is profusely illustrated and includes glossary of nautical terms.

6. Planking the Built-Up Ship Model

By Jim Roberts, Model Shipways 1987

A detailed, step-by-step procedural guide to the historically and technically correct methods of planking ship models. The information is also useful for over-planking solid hull models.

Note: Many books are available through Model Shipways web site, www.modelexpo-online.com.

Please check current catalog or website for availability.



Scale Models of Legendary Wood Ships

HMS BOUNTY'S LAUNCH

Length 17-1/4"
Height 14-3/4"
Beam 5-3/8"
Scale (1:16)

No. MS1850



DAPPER TOM

Length 24"
Height 18"
Scale 5/32" = 1 ft.

No. MS2003



NEW BEDFORD WHALEBOAT, C. 1850-1870

Length 24"
Height 4-5/8"
Scale 3/4" = 1 ft. (1:16)

No. MS2033



HARRIET LANE

Length 19-1/2"
Height 9-1/2"
Scale 3/32" = 1 ft.

No. MS2010



PINNACE

Length 11-3/4"
Width 2-1/2"
Scale 1/2" = 1 ft. (1:16)

No. MS1458



18TH CENTURY LONGBOAT

Length 11-3/4",
Scale 1/4" = 1 ft.

No. MS1457



PHANTOM, NEW YORK PILOT BOAT

Length 13-1/2"
Height 13-1/2"
Scale 1/8" = 1 ft.

No. MS2027

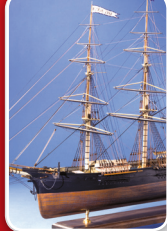

FLYING FISH

Length 36"
Height 22-1/2"
Scale 1/8" = 1 ft. (1:96)

No. MS2018

MAYFLOWER, 1620

Length 22"
Height 17"
Scale 5/32" = 1 ft.

No. MS2020



FAIR AMERICAN

Length 26-1/2"
Height 22"
Scale 1/4" = 1 ft. (1:48)

No. MS2015



SULTANA

Length 17"
Height 15" Scale 3/16" = 1 ft. (1:64)

No. MS2016



RATTLESNAKE, PRIVATEER, 1780

Length 28"
Height 18"
Scale 3/16" = 1 ft. (1:64)

No. MS2028



GUNBOAT PHILADELPHIA

New from Bob Crane, designer of USN Picket Boat No. 1

No. MS2263



WILLIE L. BENNETT, SKIPJACK

Length 24"
Height 16"
Scale 3/8" = 1 ft. (1:32)

No. MS2032



USS ESSEX

Length 27"
Height 8"
Scale 5/32" = 1 ft. (1:76.8)

No. MS2041

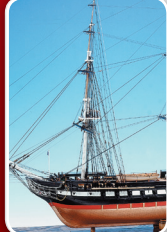

USS CONSTITUTION, 1797

Length 48"
Height 32"/Width 16"
Scale 5/32" = 1 ft. (1:76.8)

No. MS2040

BENJAMIN W. LATHAM

Length 33"
Height 27"
Scale 1/4" = 1 ft. (1:48)

No. MS2109



PRIDE OF BALTIMORE II

Length 32"
Height 22-1/2"
Scale 3/16" = 1 ft. (1:64)

No. MS2120



BLUENOSE, CANADIAN FISHING SCHOONER

Length 32"
Height 26-1/2"
Scale 3/16" = 1 ft (1:64)

No. MS2130



CHARLES W. MORGAN, WHALING BARK

Length 25" Scale 3/16" = 1 ft. (1:64)

No. MS2140



EMMA C. BERRY LOBSTER SMACK

Length 26-3/8"
Height 28-1/2"
Scale 3/8" = 1 ft (1:32)

No. MS2150



ARMED VIRGINIA SLOOP

Length 31"/Height 18"/Width 8-1/4"
Scale 1/4" = 1 ft. (1:48)

No. MS2160



GLAD TIDINGS, PINKY SCHOONER

Length 29-1/2"
Height 23" /Scale 1/2" = 1 ft. (1:24)

No. MS2180



CHAPERON, STERNWHEELER

Length 34-1/2"/Beam 7-1/2"/Height 12"/ Scale (1:48)

No. MS2190

NIAGARA, U.S. BRIG 1813

Length 36-1/2"
Height 24-1/2"
Scale (1:64)

No. MS2240



SYREN, US BRIG 1803

Length 33"
Height 27"/ Scale 3/16" = 1 ft (1:64)

No. MS2260



U.S.N. PICKET BOAT NO. 1, 1864

Length 22-1/2"
Width 5"/Scale 1:24 (1/2" = 1 foot)

No. MS2261

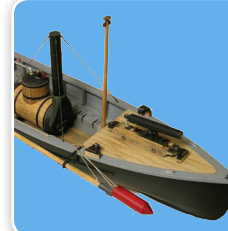

CONFEDERACY

Length 35"
Height 8-1/2"
Scale 3/16" = 1 ft

No. MS2262

