

Instruction Manual

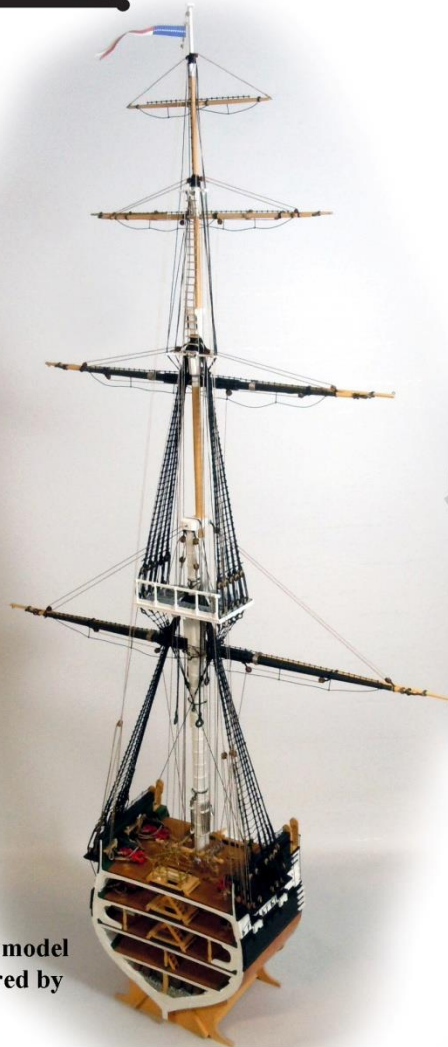

Modeling the **U.S.S. Constitution** Cross Section

1797



Instructions and model
prototype prepared by

Ken Foran

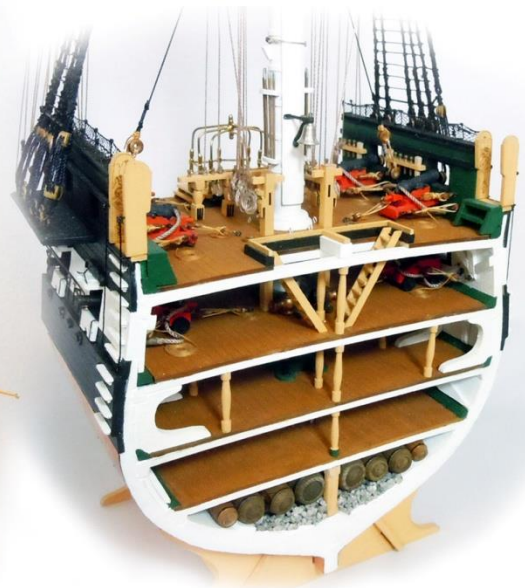

Kit No. MS2045

Scale: $5/32'' = 1 \text{ ft. } 1:76.8$

Overall Length: 4''

Height: 32''

Made in the USA with Pride by

Model Shipways

A division of Model Expo

WWW.MODELEXPO-ONLINE.COM

Copyright Model Expo 2019

Just a few nautical ship terms:

Aft: At, in, toward, or close to the rear of the ship.

Belaying Pin: a wooden pin used to secure a rope fastened around it.

Block: Oval wooden blocks with sheaves (pulleys) for rigging ropes and tackle.

Bow: The front of the ship.

Bulkhead: A partition or dividing wall within the hull of a ship.

Deadeye: Round wooden block with holes to setup the ship's stays.

Halliard: Rope or tackle used to raise and lower sails.

Hull: The body of the ship defined by planks.

Keel: The main longitudinal timber of the hull, upon which the frames are mounted

Keelson: Lengthwise wooden beam in ship for bearing stress.

Knees: Carved braces located to reinforce the hull.

Main: The longest mast located in the middle of ship.

Port: The left side of the ship when you are facing toward the bow.

Rabbit: An angled cut in the keel to receive hull planks.

Rigging: Ropes, chains, and tackle used to support and control the masts and sails.

Shrouds: Ropes supporting the mast from the mast head to the sides of the ship.

Stay: Large ropes used to support a mast.

Stern: The rear part of a ship.

Starboard: The right side of the ship when you are facing toward the bow.

Treenail: Long wooden pegs used to affix planks to frames of the hull.

Yard: Wood beams to which the sails are attached upon.

Before You Begin to Build

At 5/32" = 1' 0" (1:76.8) scale, it is relatively easy to build this U.S.S. Constitution cross section model and obtain precise detail. Laser cut parts offer a simple building method. Britannia (white metal) parts eliminate creating metal parts from scratch. However; some metal fittings will need to be formed using brass strips for authentic detailing.

Before starting to assemble the model, carefully examine the kit and study the **Plan Sheets** and the **Assembly Instruction Manual**. First, determine if all the listed kit parts are present using the **Plan Parts Layout Sheet #3** and **Assembly Instructions**. Handling the parts will produce a better understanding of the kit's building requirements. Try to visualize how every piece will look on the completed model. Also, try to follow the building sequence and what must be completed first, or ahead of time and what can be done simultaneously if you wish. For example, you may want to skip to the mast construction as you are working on the hull or waiting for glued assemblies to set or paint to dry.

The Plans: Plan sheets are provided for reference and part identification and may not be exactly true to scale due to the reproduction process. These drawings show elevation views, a parts layout with color

guide for some parts. Review and study the plans and assembly instructions prior to starting the build to better understand how the parts will come together and the proper build sequence.

Make Allowances: Try to be exact when following the instructions, but use common sense. Adjustments may be necessary to compensate for small differences in how your model is shaping up and how the parts are relating to each other. An old saying in the model building craft is that “if it looks right, it is right.” Also check the instruction photographs for various details before working on them.

Kit Lumber: Laser cut Basswood parts are supplied in the kit. A word about laser cutting: a common misconception is that the parts should punch out of the carrier sheet. This is not so. Laser cut parts are retained in the carrier sheet by small bridges of uncut wood called tabs. Tabs can be oriented parallel to the wood grain or perpendicular to the wood grain. It is always better to cut through these tabs rather than try to punch out the parts by breaking the tabs. You may have to cut through not only the tabs but portions of the part outline that did not cut completely through the sheet. Turn the carrier sheet over and cut from the backside to release the part without damage.

Britannia Metal Parts: There are Britannia (white metal) parts in this kit. First, remove any mold joint flash with a #11 hobby blade using the back edge as a scraper, then file or sand with fine sanding stick or sandpaper. **Important: Always dry fit parts together first to determine if holes need to be drilled further or if mating surfaces are flat to each other.** Once parts have been dry fitted wash parts in dishwashing liquid and warm water to remove traces of mold release agent and the body oils your fingers may deposit. Allow the parts to dry thoroughly before applying primer and painting. Try to avoid painting, whenever possible, surfaces to be glued together, or locating pins that insert into holes. Due to the metal casting process used; some deformed parts may be received, or filled in holes that will have to be drilled. These can be straightened by **gently and slowly** reforming with your fingers. Check with the plans and photographs to verify the reforming of the part(s); every effort was made to reproduce the parts accurately but some deforming may occur during shipping due to the weight of the parts themselves.

Photo Etched Parts: Etched brass sheet of parts are included in the kit. Sand the surfaces carefully with fine sandpaper to remove surface oxidation. Care must be used to cut these parts from the carrier sheet using the tip of a hobby knife blade on a hard surface like steel or use small scissors/snips. Cut tabs may need to be filed smooth using a fine needle file.

Dowels: Quality dowels are provided for the mast and yards. The best way to taper is by hand using a sharp #11 hobby knife blade in conjunction with sandpaper and sanding block and slowly working back and forth with them. It is much better to use small short cuts with the blade so as not to gouge the dowel. Also due to wood grain there is an easy way to cut and a harder way to cut down the length of the dowel. When starting to cut and it is difficult with gouging turn the dowel end for end. **Do this as a test before cutting dowels** to length for a part. A dowel can also be tapered by chucking it into an electric drill as the speed of the drill turns the dowel, use sandpaper to shape and taper. They can also be turned on a lathe if one is available.

Glues: Super glues, such as Jet, Flash, or Zap, produce quick adhesion. For most applications, the medium viscosity, gap-filling variety is best allowing a little time for final positioning. The thin type is recommended for filling a narrow crack, wicking into laminated tight joints and seizing rope ends to

make “needle” points. These instructions will refer to super glues as CA (cyanoacrylite). For the majority of wood glue joints it is best to use Yellow Wood glue like Titebond which is easier to sand than CA which hardens the wood. A mix of 50/50 white glue and water is used on rope seizing and rope knots, which will remain flexible rather than CA which will harden the rope. CA should only be used on rope work very sparingly.

Laser cut parts: There are Basswood and Plywood laser cut parts and laser cutting burns through the wood and leaves a charred surface. The Basswood parts are cut using various thicknesses of sheet stock resulting in various levels of char, while the Plywood only one, but the Plywood is more heavily charred than Basswood. This charred surface sometimes does not make good strong glue joints. It is recommended to lightly sand or scrape away the loose char before gluing. It is not necessary to remove all the char, unless a finished wood surface is required. In some cases simply scraping with the back edge of a # 11 blade is sufficient on Basswood. The use of a small sanding drum in a rotary tool with a light touch would work best on the plywood edges.

Building Tips and Suggestions before Starting to Build

- Read assembly instructions, study the pictures and review the plans to understand and familiarize yourself with various parts and components and how they relate to each other.
- Check parts list to make sure you have all the parts listed.
- Verify that you have all the tools and materials needed to start the build. See the materials list and suggested tool list. A variety of clamps is essential see the recommended numbers.
- Try to follow the suggested build sequence outlined in the assembly instructions.
- Pay attention to steps that are **BOLD** face type. These are critical actions to avoid problems with assembly or when extra care is needed.
- Parts are **Capitalized** and may be **Boldface** on purpose for emphasis and identification when reading and easy reference. Part numbers with brackets (**xxxx**) are rope lines.
- Cast white metal parts in some cases are delicate due to replicating in scale. Extra care and caution is required when cleaning, filing parting lines and adjusting to dry fit.
- Prime, paint and dry fit all cast parts prior to assembling. Keep primer and paint to a minimum to keep fine details crisp. When dry fitting parts if excess paint is an issue scrap off paint as needed for a good fit. Fill casting voids with putty if required and then sand and prime.
- When carving with a hobby knife blade remember that a slicing action with the blade will net better smoother results. Work and carve with sharp blades.
- Take your time, learn and enjoy the build process as much as the finished model.

Building Strategy: Due to the number of laser cut parts in the kit; it is recommended to clean, file, dry fit and paint sub-assemblies only as needed. Another option for building the kit is to do the full deck planking or half deck showing the deck beam framework. The following instructions will address some sub-assemblies of components to be worked on and then set aside for later assembly. The instructions

will address building as the historic version of the ship. The hull will be built from the inside out and from the hold up to the spar deck. **It is important to follow the sequence to avoid building issues later on.** Some parts will go through multiple decks. It is also advisable to paint parts as needed to keep a clean crisp build. The three plywood hull frames have a designed in building fixture base for ease of construction. As the build progresses, the open corners of the frame base should be used to grip and handle as needed.

Materials that will be needed:

- Medium CA –Small Bottle
- Thin CA – Small Bottle
- 1 small bottle of Yellow Glue.
- 1 small bottle of White Glue.
- Fine sand paper or sanding sticks.
- 1 Bottle MS 4802 Gun Carriage Red
- 1 Bottle MS 4828 Iron Cannon Black
- 1 Bottle MS 4830 Hull Spar Black
- 1 Bottle MS 4817 Bulwarks Brown
- 1 Bottle MS 4831 White
- 1 Bottle MS 4839 Primer
- 1 Bottle MS 4972 Natural stain.
- 1 Bottle MS 4963
- 1 Bottle MS 4970 Copper
- 1 Bottle MS4973 Pre-stain Wood Conditioner
- #2 and #7 Round paint brushes.
- 10/0 spotter paint brush for touch up.
- 1/2" Flat brush.
- 1 spray can of Matte Finish.
- 1 spray can Metallic Gold.
- Small can of Acetone – if needed to debond glue.
- Card stock 4 - sheets for creating part templates.
- Small pins/ T-pins available at Craft Stores.

Suggested tool list:

- Hobby knife blade holder.
- #11 blades - 12- 18 as needed. 1 chisel blade.
- Hobby Knife Saw Blade
- Small needle nose pliers.
- Small end cutters.
- Tweezers – straight and bent.
- Medium size Mill Bastard file.
- Needle files. Flat , Half Round, and Square
- ScotchBrite pad- Fine and Medium.
- Sanding paper/stick – 80,100,120,220 grits.
- Set of small reams to clean holes.
- Small Square.
- Several round toothpicks.
- Round flat drift punch.
- Wax paper.
- Masking tape- automotive low tack
- Drill Bits 1/32"; 3/64";1/16"; 1/4:"
- Pin vise for drill bits.
- X –Y table for drill press.
- Mechanical Pencil .05 lead sizes.
- Small 4" bar clamps – 2 to 4
- Metal spring clamps - 2 to 4
- Small Plastic clamps – 10 to 12
- Small package of Clothes pins.
- A variety of flat rubber bands.
- 1 Stainless steel pick – bent ends.

The **Materials List** identifying the parts supplied in the kit is a separate document to this manual, as well as, **Plan Sheet 3** with part drawings for easier part identification.

BUILDING THE BASIC HULL FRAME STRUCTURE:

Frame: Assemble the plywood **Frame** parts and carefully cut the connecting tabs to free the parts from the carrier sheets. The top braces may break loose from the frame so glue them back in place as

needed. Cutting the plywood tabs is best done using a chisel blade with a rocking action first on the front and then the backside of the carrier sheet.

Clean all plywood **Frames** (3), **Base Cross Members** (2), **Spacers** (8) and **Mast Locator** (1) laser cut edges. Use a small drum sander and/or rotary tool to clean the excess char from all edges including the deck beams. All slots in the **Frames** and **Cross Members** need to be filed for a press fit of the slots, this will reduce the amount of force needed when to be assembled. All **Spacer** slots need to be filed for a **looser slip fit** to be moved as needed. Dry fit all slots before final assembly of **Frame** units. See photos below.

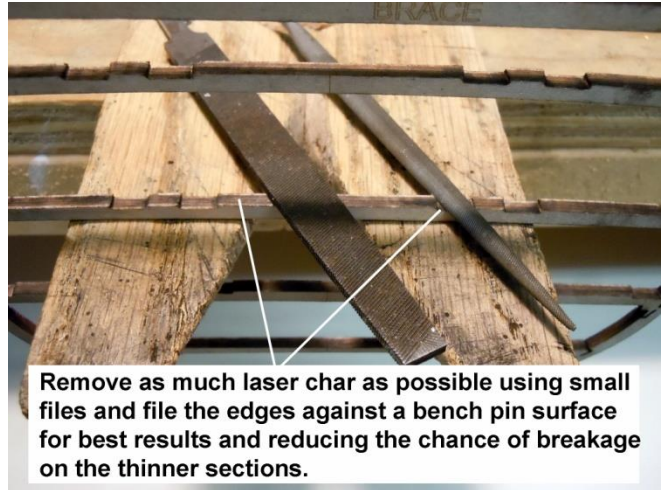
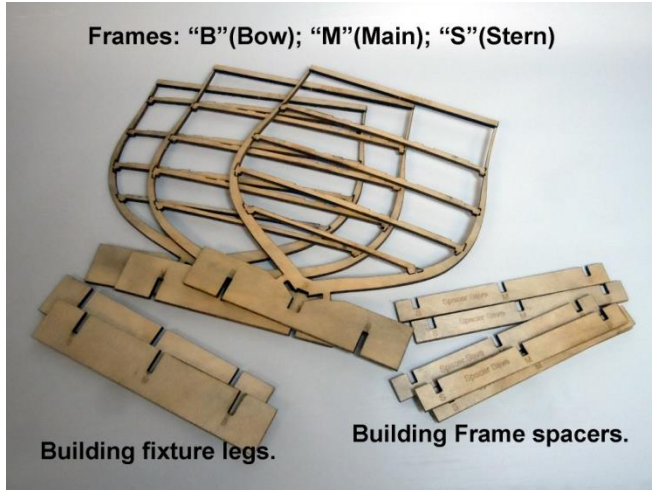

Glue the Mast Locator on the top brace of **Frame M** centered between the laser burned locator arrow heads. See photo below.

Once satisfied with the dry fitting of all the slots as needed, assemble the **“M” Frame** with the two (2) **Cross Members** indexing the **“M”** slots with the **“B”** ends on the **“Forward”** side. **“B”** stands for bow, **“M”** (Main) mid ship and **“S”** for Stern. This is true for **Frames** and **Spacers** and always index **Spacers** accordingly when moved during the build process. Now add the **“B”** and **“S” Frames** indexing with **“Forward”** facing in the correct direction. Carefully add **Spacers** with three on the Spar deck beam, one centered on the gun deck and two on the orlop deck. The **Spacers** will maintain the correct frame spacing as the build progresses and will be moved as needed. The basic **Hull Frame Structure** is now complete. The distance from the bow **Frame** to the stern **Frame** should be 4 inches. Care throughout the build should be used to maintain this 4 inch dimension. See Photo below.



Keel: Cut a 1/4" x 1/2" x 4" Basswood keel and dry fit into the vertical slots at the bottom of the three (3) **Frames**. Now mark the location for the **Rabbet** cut where the **Frames** intersect the **Keel** on both sides of the **Keel**. Looking at each end mark with a pencil the extended lines for the **Rabbet** cut and mark the **Bow** end with a **B** for reference when replacing. Remove the **Keel** and join the pencil marks with two (2) parallel lines. With a sharp blade cut along the lines with the blade angled per the end marks to form the **Rabbet** cut. See detail on **Plan Sheet 1**. True up the cut if necessary with a square file held at the correct angle. When satisfied replace the **Keel** back into the **Frame** slots and glue the flat section of the **Frames** to the top surface of the **Keel** only. See photos below and **Plan Sheets**.

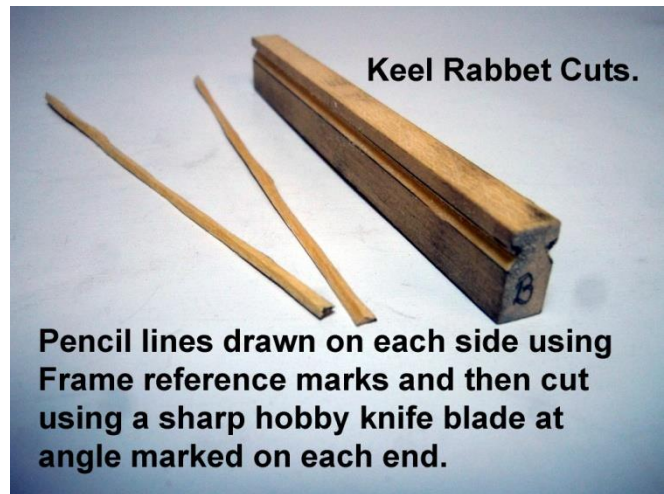
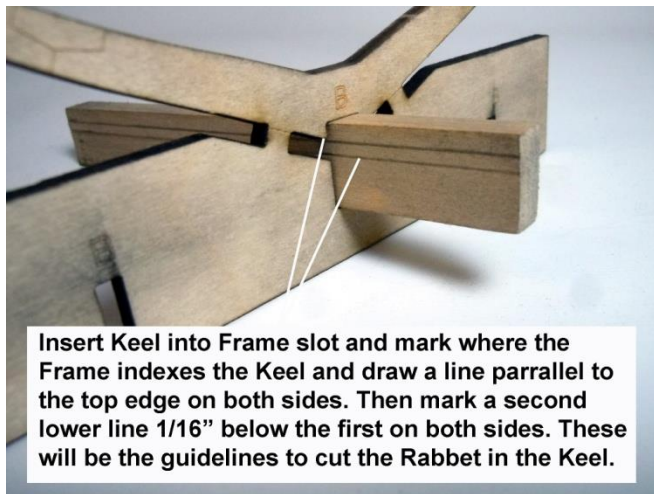

Keelson: Now cut and dry fit two (2) Basswood pieces 1/4" x 9/32" x 1- 13/16" to press fit on top of the **Keel** between the **Frames**. The top surface **should be flush** with the flat section on the **Frames**. See photo on the next page.

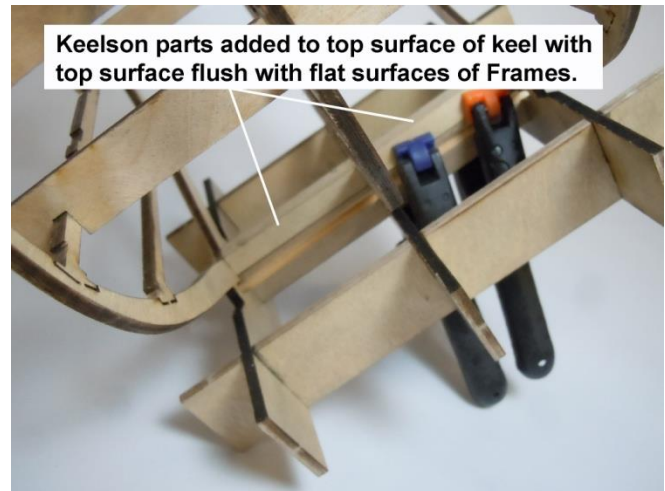
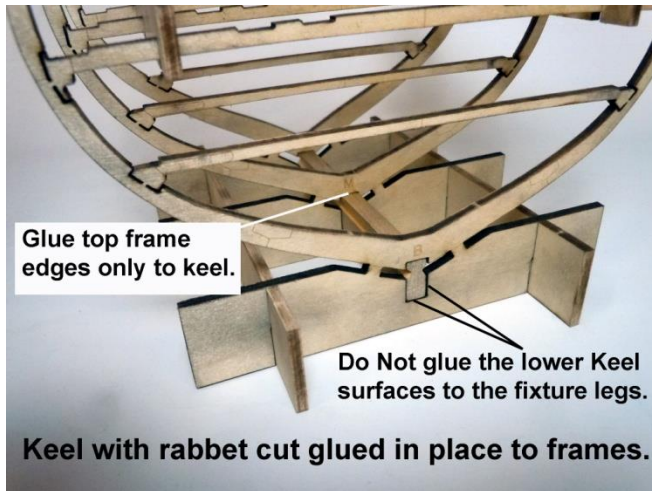

Next cut the **Keelson Cap** from 1/4" x 1/4" strip 4" long and glue to the top of the **Keelson** parts. See photo below and Plan Sheet 1.

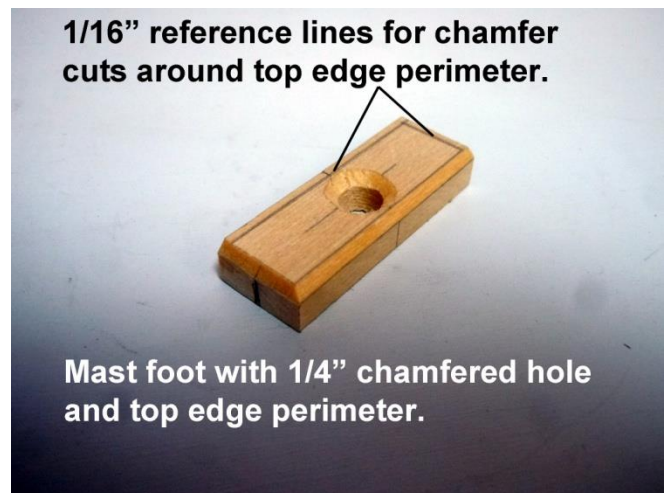

BUILDING THE HOLD:

Cut **Mast Foot** 1/2" wide x 1 -1/2" Long x 1/4" high. Draw pencil centerlines on top sides and ends; then drill a 1/4" hole on center length and width. Carefully cut a 45 degree angle around the top edge of the hole that will mate with the angle to be cut at the base of the **Mast**. Next draw pencil lines 1/16" in from the top and side edges and then cut a chamfer around the top edge. See photo above.

Cut two (2) 1/4" x 1/4" x 4" **Limber** pieces to fit on either side of the **Keelson**. Fit them against the side of the **Keelson** and mark a vertical line on each end parallel to the side of the **Keelson** and also mark a "B" on the bow end for reference. See Photo below. Cut each side of the **Limbers** to match the **Keelson**. Now mark the center mark for the **Mast** location on top of the **Keelson** 1-1/2" from the **Bow** end on center side to side. Align the **Foot Mast** centerlines with the center mark on top of the **Keelson** with the **Limbers** clamped in place and mark the ends of the **Foot Mast** on the **Limbers** to be cut flat to match the **Mast Foot** so that it sets flat. Cut the marked areas on the **Limbers** and check for the **Mast Foot** setting flat. Also extend the **Limber** lines down the sides for reference later. See Photos on the next page.



Once the **Limber** flats are cut reset the **Mast Foot** on the center mark and mark the sides of the **Mast Foot** on the flats of the **Limbers**. Locate a 1/16" thick strip to use as a guide on with the **Limbers** in place and mark a line the length of the **Limbers**. This line will be the plank thickness. Now cut an angle on each **Limber** from the **Mast Foot** side mark down to the 1/16" plank line. Now angle cut the **Limbers** from each end of the **Foot Mast** from the 1/16" plank line up to the **Keelson** edge. See Photo below with White lines defining the cut surfaces on the **Limbers**.

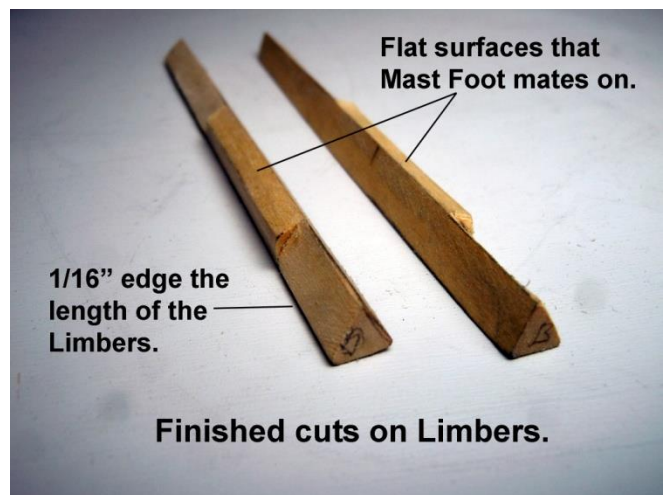

Once satisfied with **Limber** fits glue the **Limbers** in place to the sides of the **Keelson**. Take care to note and align the **Bow** ("B") ends with **Frame**. Then glue the **Mast Foot** in position aligning it on the center mark on top of the **Keelson** as seen in photo above.

Remove **Hold Walls** from 1/16" thick parts **WP2045-M**. The top edges have extra material to allow for building variances so these edges need to be trimmed and sanded for a snug fit. Work slow and patiently for best results. Once dry fitted and spring clamped in place to the middle **Frame**; apply water to the underside and this will allow the walls to conform under clamp pressure to the **Frames**. Allow overnight to dry and set.

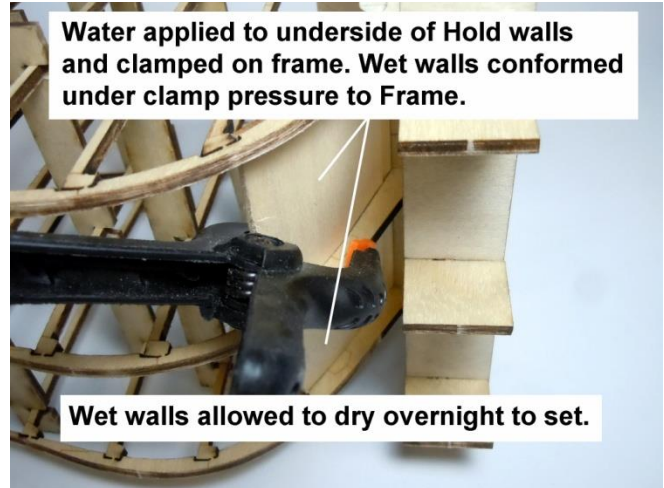
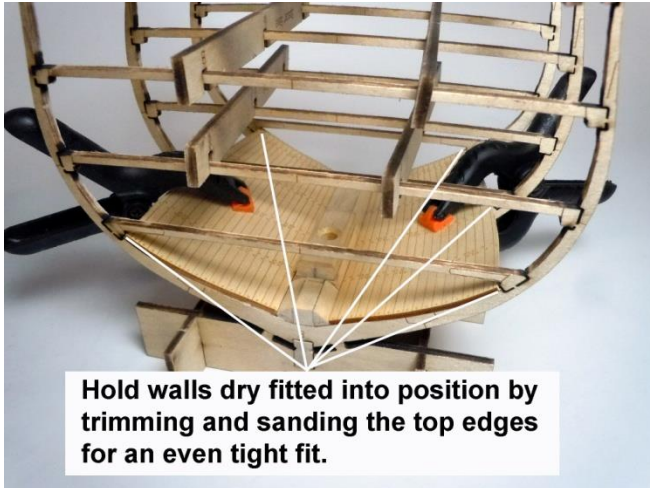

Using 1/16" thick x 1/4" wide Basswood strip, cut and fit **Diagonal Bracing** (port and starboard) from the **Bow** tangent to the **Keelson** rising to the **Stern** below the **Orlop Deck Beam**. See photo below. Cut and fit two (2) shorter **Diagonal Braces** starting at the **Middle Frame Orlop Deck Beam** and forward to the **Bow** parallel to the longer **Braces**. Once **Hold Walls** are dried then paint both **Hold Walls** and **Diagonal Braces White MS4831**. Best results are obtained by applying two thinned coats so as not to lose the laser cut details of the joint lines and tree nails. Thicker paint could fill the laser cut details. See photo below. When completely dry glue the **Hold Walls** in place and then the **Diagonal Bracing**.

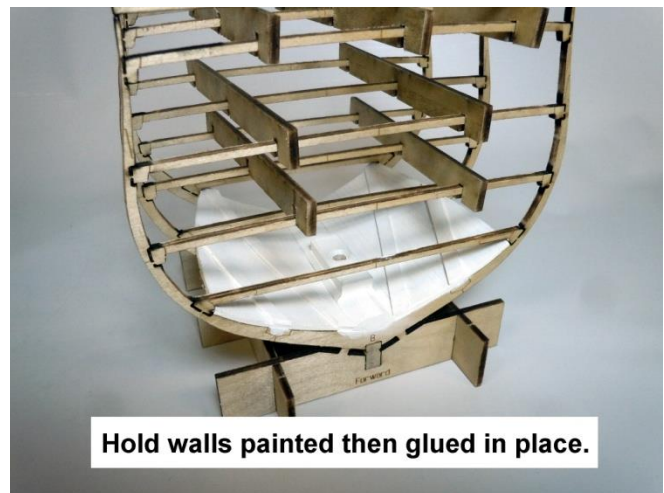

Posts: Using 3/16" x 3/16" wood strip cut two (2) lengths from the **Keelson** to the **Frame** deck beams fore and aft; then cut one (1) from the **Mast Foot** to the middle deck beam. Make sure that the center beam is close to flat relative to the fore and aft beams; if necessary clamp a strip to hold it in place with the other two until the center **Post** glue sets. Then mark from each end a reference pencil line on all four (4) sides. From the reference lines next mark lines top to bottom 1/32" in from all edges. At the intersections of the 1/8" on the edge plunge cut at a 45 degree angle all sides. Next, carefully with a sharp hobby knife cut edges top to bottom using the 1/32" lines smooth beveled surfaces joining the plunge cuts forming small triangles at the intersections. See photos below. Once all **Posts** are dry fitted, stain them using **Natural Stain MS4972** and when dry, glue the middle **Post** centered vertically

on the centerline mark on the **Frame** deck beam and the **Mast Foot**. Then glue the fore and aft **Posts** with the surfaces flush with the **Frame** deck beam and **Keelson**. See photo below.

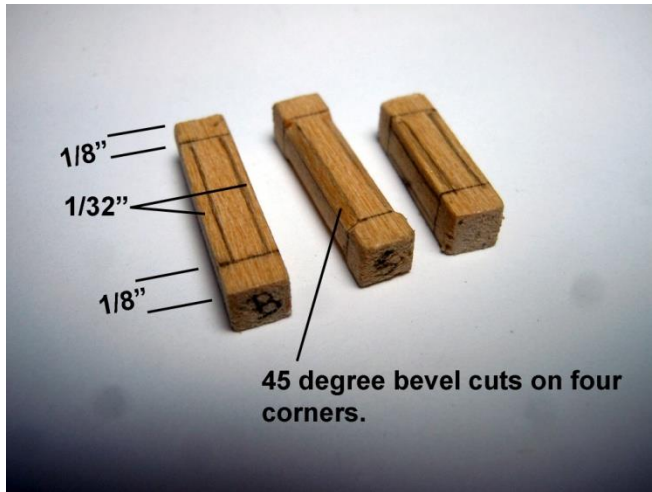

Ballast Stone: Mask off each end of the hull aligning the top edge of the tape with the top edge of the **Mast Foot**, add a piece of tape over the **Mast** hole to prevent stone falling into the hole. Mix a combination of 50/50 White glue and water and add the mixture to a small amount of the **Ballast Gravel** and mix thoroughly. Using a flat mixing stick add the wet **Gravel** to the hull working slowly around the **Mast Foot** towards the taped ends. It is important to achieve a flat as possible surface of **Gravel** level to the top surface of the **Foot Mast** and transitioning at a slight angle from the **Bow** to the **Stern**. Using tweezers can help in the leveling process and moving or adding individual stones when fine tuning the finished bed of **Ballast**. Allow to dry completely before removing the tape from the ends. See Photos below.



Barrels: Darken the iron rings on the following **Barrels** – 4 small **MS0387**; 6 medium **MS0388**; 4 large **MS0389** using a Black pointed marker. Glue 2 large; 4 medium and 2 small in position across the **Bow** end of the **Hull** and 2 large; 2 medium and 2 small in position at the **Stern** of the **Hull**. See photo below.

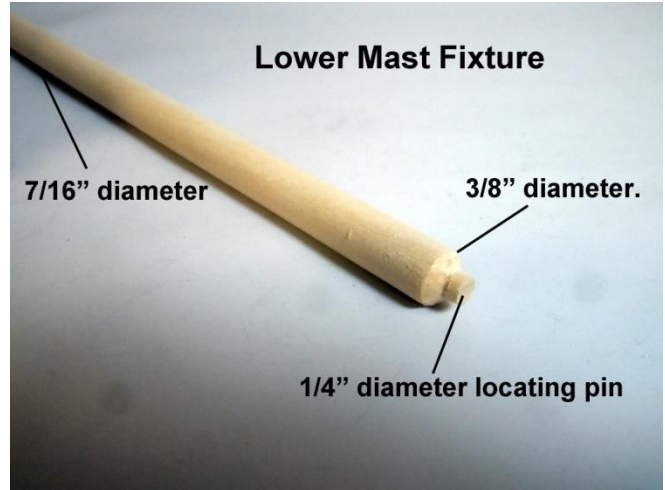

ORLOP DECK:

A **Lower Mast Fixture** will need to be made before the **Orlop Deck Planking** and the rest of the decks can be added due to **Mast** location holes in the **Deck Planking** parts. Cut a 7" length of 7/16" dowel; cut a 1/4" diameter locating pin with a 45 degree chamfer to match the hole in the **Mast Foot**. Note that the **Mast** will have a **3.5 degree** angle towards the stern when cutting the locating pin. Next sand a taper starting 4" up from the chamfer and sand down to the base to a 3/8" diameter to match the **Mast Foot**. Test fit into **Mast Foot** until satisfied with **Fixture** fit. See photo above.

Locate the **Orlop Deck Planking** parts (2) and apply a stain coat of **English Oak Stain MS4975**. Once the stain has dried then glue the two (2) parts together; take care and wipe clean with a wet cloth any excess glue that may migrate to the stained surface. When glue has set spray the stained surface with a **Clear Matte Finish** to protect the stain. While waiting for parts to dry remove the curved laser cut **Stringers** for the **Orlop Deck** and mark a 1/16" line on the top surfaces to match the wall thickness. Now angle cut the outboard surfaces to match the angle of the **Frames**. Next angle cut from the 1/16" pencil line down to the inboard lower edge. When sanded smooth then paint with two (2) coats of **Dark Green MS4801** and set aside to dry. See photos below.

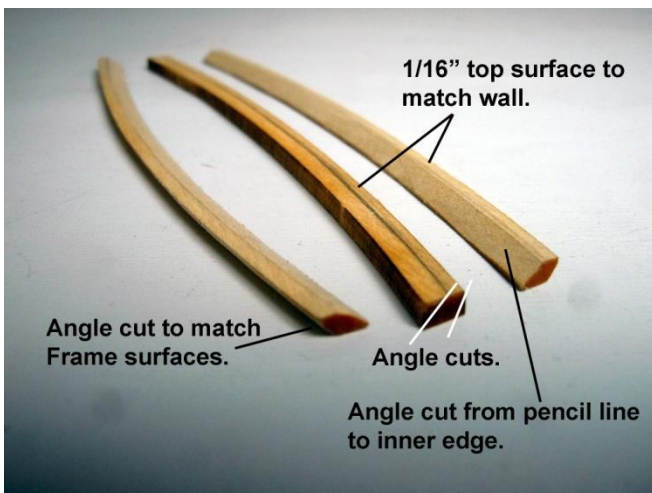

Next, shape half round the edge of the **Mast Surround** and then paint it with two (2) coats of **Dark Green MS4801** and set aside to dry. Before adding the **Orlop Deck Planking** paint White the facing

surfaces of the **Bow** and **Stern Plywood Frames**. These surfaces are much easier to paint without decks in place. See photo above. Dry fit the **Orlop Deck Planking** using the **Mast Fixture** inserted through the **Mast Locator** on the top brace, through the deck hole into the **Mast Foot**. If adjustment is needed sand the deck mast hole fore or aft as needed, keep in mind to allow for paint on the finished **Mast**. Once satisfied with the fit, glue the **Orlop Deck Planking** in place using the centerline on the **Frames** for reference along with the **Mast Fixture** in place. Now paint the **Orlop Deck Side Walls** White and when dry glue in place clamping to the **Frames** until the glue sets. See photo below. Next, glue in place the **Dark Green Stringers** while the **Mast Fixture** is still in place. Once **Stinger** glue has set remove the **Mast Fixture** then add the **Dark Green Mast Surround** and re-insert the **Mast Fixture** back in place. Slide the **Mast Surround** up the **Fixture** enough to add glue to the **Deck Planking** to glue the **Mast Surround** in place. See photo below.



Orlop side walls glued in place.



Green stringers and mast surround glued in place.

BERTHING DECK:

Locate the **Berthing Deck Planking** sections (2) and apply a stain coat of **English Oak Stain MS4975**. Once the stain has dried then glue the two (2) sections together; take care and wipe clean with a wet cloth any excess glue that may migrate to the stained surface. When glue has set spray the stained surface with a **Clear Matte Finish** to protect the stain.

Remove two (2) of the 3/16" x 3/16" curved laser cut **Waterways** marked "B" for the **Berthing Deck** and mark a 1/16" line on the top surfaces to match the side wall thickness; next mark a 1/16" line on the inboard curved side to match the thickness of the **Deck Planking**. Now angle cut the outboard surfaces to match the angle of the **Frames**. Next angle cut from the 1/16" pencil line on the top surfaces down to the 1/16" pencil line on the inboard sides. Test fit for proper fit and sand smooth. Then paint with two (2) coats of **Dark Green MS4801** and set aside to dry. See photos below.

Next, shape half round the edge of the **Mast Surround** and then paint it with two (2) coats of **Dark Green MS4801** and set aside to dry.

Locate, test fit, adjust if necessary for a tight fit then paint White the port and starboard **Berthing Deck Sidewalls** and set aside to dry.

The **Berthing Deck, Gun Deck** and **Spar Deck** will have the structural framing parts in two (2) sections that will locate between the **Frame** beams. The **Bow** (forward) section for each deck will have the **Mast Hole** location. Below is a picture of the **Berthing Deck and Framing Structures** in their carrier sheets.

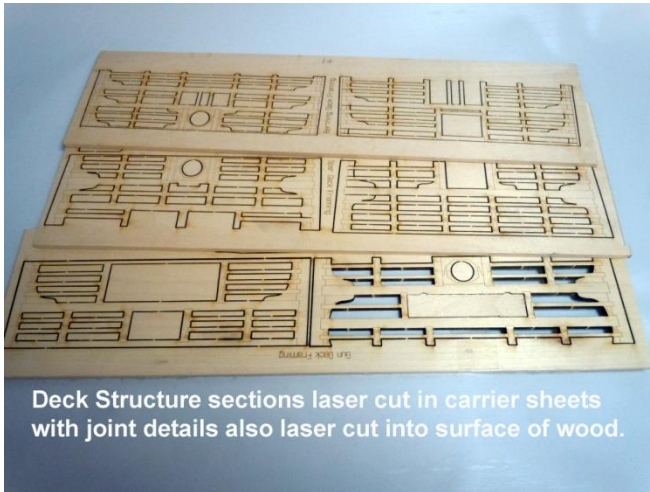

Deck Structure sections laser cut in carrier sheets with joint details also laser cut into surface of wood.



Typical Deck Structure with edges filed to remove tabs and painted White.

The **Deck Framing** sections are symmetrical; so if the build wishes to expose the **Deck Framing** some of the **Deck Planking** can be left off to show the **Framing** with the joint details facing up. Typically, the **Framing** is painted White except for the surfaces to be glued together. The slight arc needed to match the **Frame Beams** should be formed using a heat gun or hair dryer. **DO NOT USE WATER**; water will cause the wood part to expand in all directions due to the multiple areas cut out. The heated part can be formed over a 3/16" wood strip on a flat surface with the part pressed down with the wood strip on the centerline of the part. Note the **Deck Framing** parts are laser cut slightly larger and will need trimming for a good **Mast** fit. Keep in mind to maintain the 4" bow to stern dimension.



Berthing Deck Framing structure fore and aft sections installed. Waterways shaped, painted and glued in place.

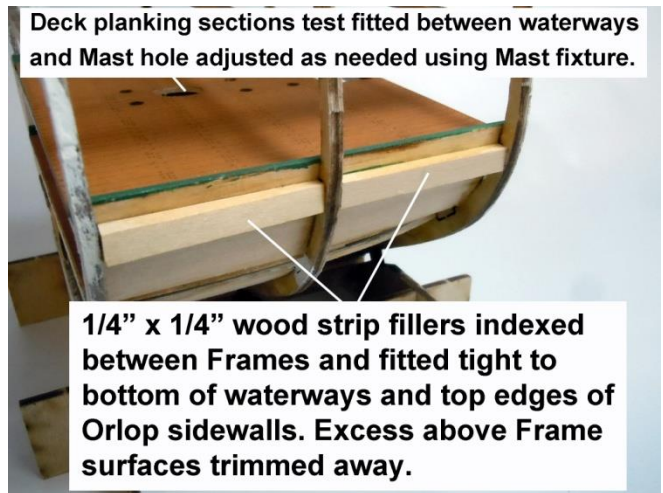

Deck planking sections test fitted between waterways and Mast hole adjusted as needed using Mast fixture.

1/4" x 1/4" wood strip fillers indexed between Frames and fitted tight to bottom of waterways and top edges of Orlop sidewalls. Excess above Frame surfaces trimmed away.

Once **Berthing Deck Framing** sections are formed and painted fit into position between the **Frames** and centered. Use the **Mast Fixture** to locate the forward section with the **Mast** hole. Once satisfied with **Sections** fitting into position "on center" and **Mast Fixture** in place, glue both **Sections** in place. Now test fit and clamp the **Deck Planking** with the **Mast Fixture** in place and centered using the glued joint lines with the centerline marks on the **Frame Beams**. Next glue the painted **Green Waterways** in place tight against the edges of the **Deck Planking**. See photo on previous page.

Next using 1/4" x 1/4" wood strip cut and glue filler parts added from the outside of the hull to fit tightly in place against the top edge of the **Orlop Sidewalls** and butt against the lower surface of the **Berthing Deck Waterways**. Trim/cut away any of the fillers parts that stand above the **Frame** surfaces to not interfere with **Hull Planking** later in the build. See photo on previous page.

Test fit the two (2) **Berthing Deck Sidewalls** a slight trimming around the top edge **Frame** notches may be needed for a tight press fit. Paint them White and glue in place. Using the 1/16" x 1/4" strip cut and fit the **Diagonal Braces**. Start with an angle cut that fits the front edge of the **Waterway** at the **Bow** and will angle back and up to be centered on the **Middle Frame** as seen in the photo below. It may take a couple of cuts to achieve a tight fit. Then use the first as a pattern to cut three more **Braces**. The stern **Braces** will align with the **Braces** on the Orlop deck and end at the forward edge of the **Stern Frame** and cut along the **Stern Frame** edge. All the **Braces** will need a slight curve to fit the curvature of the sidewalls; soaking in water can help with the forming. Once formed and dried then paint White and glue in place.

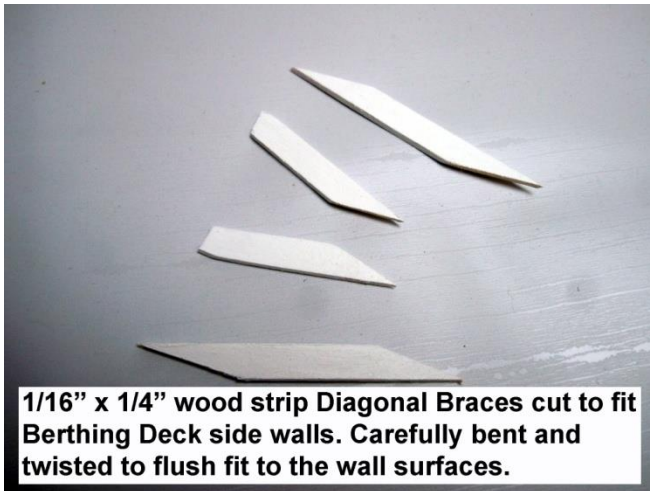

Berthing Deck Fittings: Paint **Lower Hatchway Frame** side and top surfaces **Hull Spar Black MS4830** and the inner side walls White. Using 1/16" x 1/16" wood strip carefully cut the triangular **Coaming** around three side lower edges of the **Frame**. Paint the **Coaming Hull Spar Black**. Stain the **Upper Hatchway Frame** with the Natural Stain and when dry glue centered upon the top surface of the **Lower Frame**. See photo on next page. Then glue the assembled **Hatchway Frame** with the lower edge with no **Coaming** aligning with the upper edge of the **Hull Frame Beam** and centered on the hatchway opening port to starboard to the **Berthing Deck** planking. Paint the inner sidewalls of the **Hatchway White**.

Now assemble two sets of laser cut **Hatchway Steps** as seen in photo on next page. Two pieces of scrap 1/16" x 1/2" wood strip will be needed for step spacers. Note that there are **Short** and **Long** steps, the short steps are placed between the side **Risers**. The back edges of the **Steps** align with the back edge of the side **Risers**. Front edges of **Steps** can be rounded for accuracy. Fit the assembled **Hatchway Steps** and trim if necessary for the top steps to be flush with top edge of **Hatchway Frame**. Then stain steps with Natural Stain and when stain is dry glue in place.

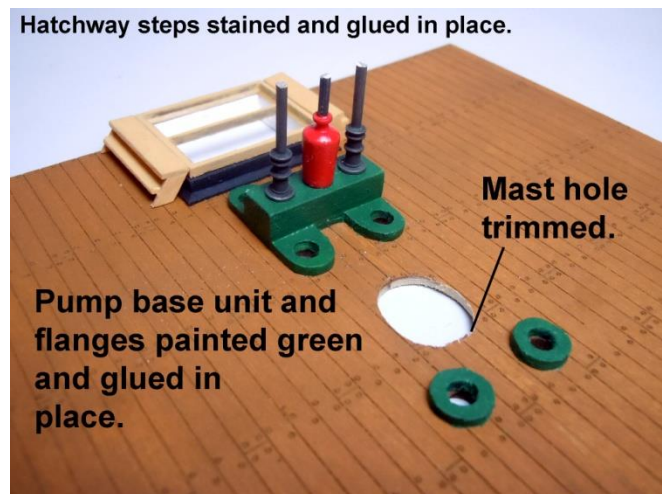
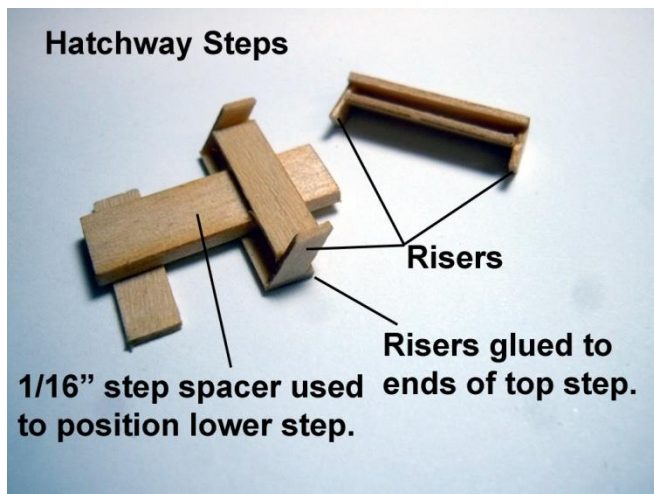
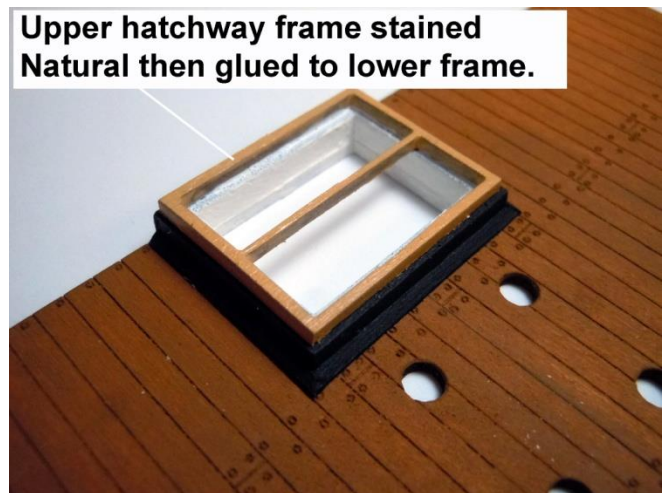
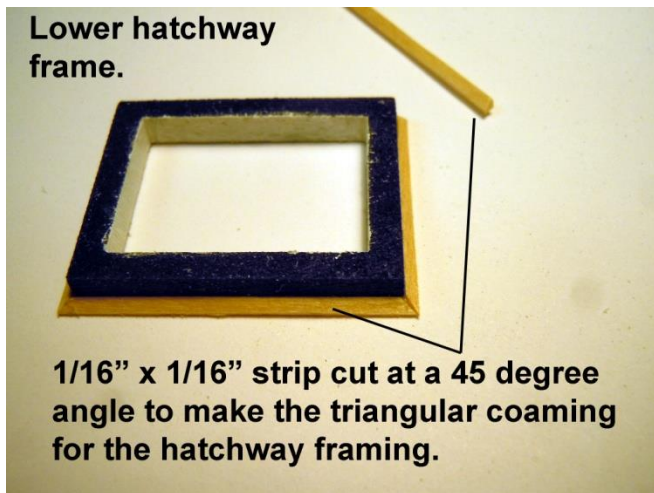

Locate laser cut **Pump Base Body Flange** (1); **Pump Base Body** (1) and two (2) **Pump Pipe Flanges**. Glue the **Pump Base Body** centered onto the **Pump Base Body Flange**. Paint assembled **Pump Base Body** unit and the two (2) round **Flanges** Dark Green. When paint is dry glue them in place centered onto the six (6) holes in the **Deck Planking**. See photo above. Locate the three cast metal **Pump** parts one (1) **Expansion Tank** and two (2) **Cylinders** with rods and paint the **Expansion Tank** Red and the rod and **Cylinders** darkened or painted Satin Black as seen in photo above. Test fit parts into holes with **Expansion Tank** in the center hole with the **Cylinders** on either side. Cut the three (3) rods to a height of 15/16" (24mm) then glue in place.

Build two (2) hatchway **Stern Ladders** using two (2) **Risers** and seven (7) **Steps**. The **Risers** have guidelines laser cut in them for reference to glue the **Steps** in place while aligning the back edge of the **Steps** with the back edge of the **Risers** as seen in the photo on the next page. The angle cuts on the **Risers** are the bottom of the **Ladder** than will set flush on the **Orlop Deck** with the top vertical cut laying flat against the inside sidewall of the hatchway. Once assembled stain the **Ladders** Natural and set aside to dry. A second coat of stain may be necessary.

With fittings in place on the **Berthing Deck Planking** glue the **Berthing Deck Planking** in place on the **Frame Structures** with a tight fit against the painted Dark Green **Waterways**. Make sure the Bow and

Stern edges are glued tight to the **Frame** beams. Allow the glue to completely set before removing any clamps used to hold in place.

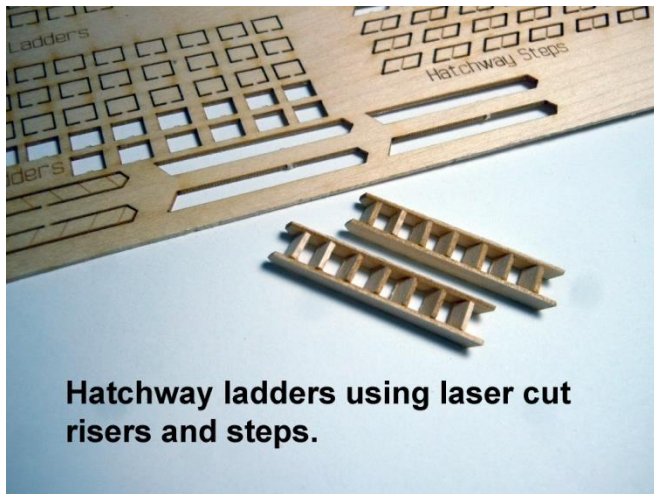

Hatchway ladders using laser cut risers and steps.

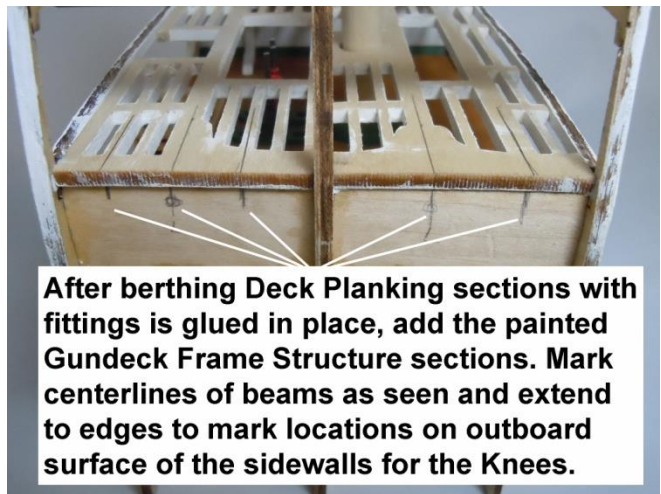

After berthing Deck Planking sections with fittings is glued in place, add the painted Gundeck Frame Structure sections. Mark centerlines of beams as seen and extend to edges to mark locations on outboard surface of the sidewalls for the Knees.

Paint the two (2) fore and aft Gun Deck **Framing Structures** and then test fit into position making sure a tight fit against the **Frame** beams and top edges of the **Sidewalls**. Be sure to maintain the 4" dimension fore and aft. Then mark the centerlines of the main beams as seen in the photo above and extend the lines to the sides and add marks on the **Sidewalls** for the locations of the **Standard Knees**. Remove the two (2) **Framing Structures** and set aside. Locate the ten (10) **Standard Knees** and sand all edges and paint White. Next glue the **Standard Knees** in place against the **Sidewalls** using the reference marks on the outboard surface of the **Sidewalls** as seen in the photos below. Next repeat the steps for the six (6) **Hanging Knees** again using the correct reference marks with the top edge flush with the top edge of the **Sidewalls**.

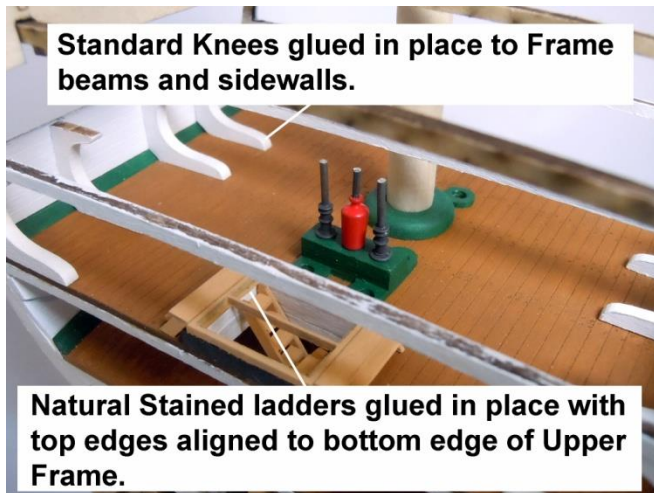

Standard Knees glued in place to Frame beams and sidewalls.

Natural Stained ladders glued in place with top edges aligned to bottom edge of Upper Frame.



Standard Knees located between Frame beams.

Hanging Knees glued in place using location marks.

Sand and paint White the fourteen (14) **Diagonal Knees**. Note there are two (2) sizes and a couple of extras of each size. Each **Diagonal Knee** will need to be cut and fit for each space between the **Standard** and **Hanging Knees** with the top edges cut at an angle flush with the top edges and side of the **Knees**. The bottom legs of the **Diagonal Knees** are cut at an angle to meet the **Knees** sides aligned with the top edge of the of the first sidewall plank line. See photos on next page.

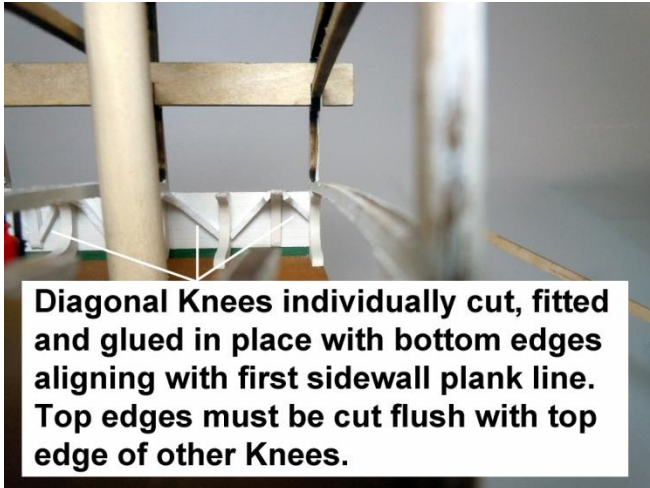

Using 1/8" Dowel carve and cut thirteen (13) **Berthing Deck Stanchions** 7/8" high. First score a cut line 3/32" from the square end of the dowel and then with a sharp hobby knife blade starting about 1/2" down from the cut line carve slowly around the dowel to a depth of 1/32" at the cut line. Next mark the 7/8" length of the **Stanchion**; then measure and carefully add the cut line at 1/8" down from the overall 7/8" mark. Now carefully carve down from the center to the cut line to rough form the **Stanchion**. Next with a small needle file smooth the carved surfaces to a tapered round shape as seen in the photo above. Then cut off from the dowel at the 7/8" mark. Repeat until thirteen (13) are complete, then stain with Natural Stain. Note that one **Stanchion** round foot will be cut flat to mate to the **Mast Surround** as seen in the photo below.



Now test fit and trim for a slight press fit the eight (8) **Stanchions** in the positions as shown in the photo above at each **Frame** beam and in front of each **Standard Knee**. Glue each **Stanchion** in place adding glue to the **Frame** beam only so as not to discolor the deck finish. The remaining four (4) **Stanchions** will be added once the **Gun Deck Frame Structure** is in place.

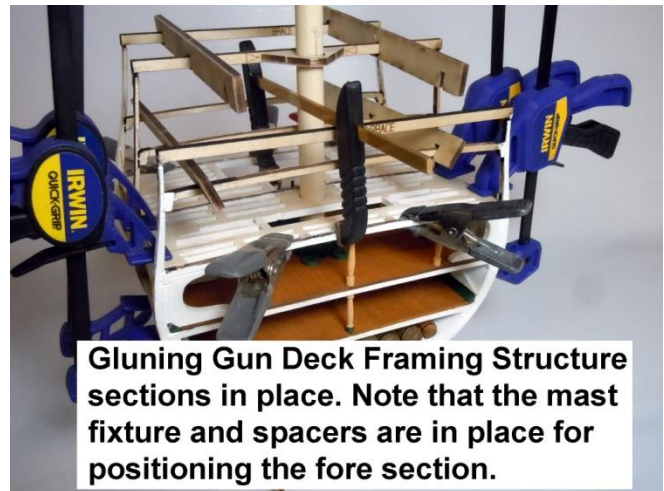
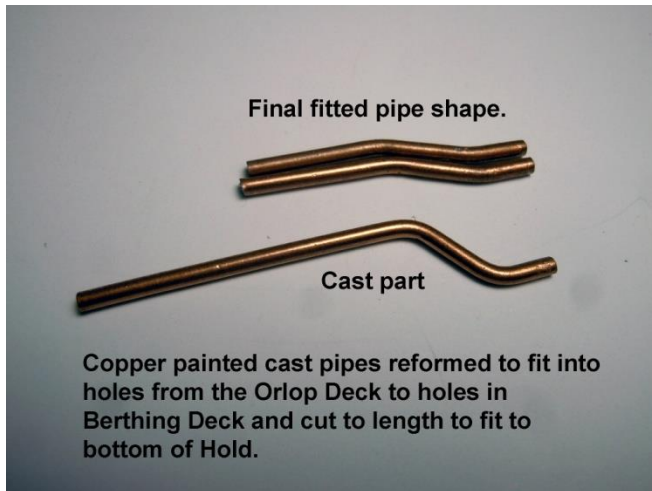

Locate the six (6) cast metal **Pump Suction Pipes** and slowly bend to cut and reform to fit into the flange hole locations on the **Berthing Deck** down through the **Orlop Deck** to seat on the gravel in the **Hold** as seen in the photo above. The goal is to have the tops of the **Pipes** index into the bottom of the **Pump Shafts**. These **Pipes** need to be loosely in place before the **Gun Deck Framing Structure** is added. Once test fitted paint the **Pipes** with **Copper MS4970** paint and when dry replace into their respective locations making sure the indexing holes on the ends for the lower shafts is up.

Next paint the two (2) **Gun Deck Frame Structure** sections White except for the upper gluing surface. Once dry insert and center the **Fore Frame Structure** section in place between the **Frame Beams** position the **Mast Fixture** then clamp in place for tight fits against the **Frame Beams** and top edges of **Sidewalls** and glue in place. See photo above. Then repeat and glue in place the **Aft Frame Structure** section following the same procedure of positioning and gluing.

GUN DECK:

Building the Gun Deck will be a little more complicated with the addition of pump equipment and rigged **Long Guns**.

Locate the laser cut **Gun Deck Planking** sections (2) and apply a stain coat of **English Oak Stain MS4975**. Once the stain has dried then glue the two (2) sections together; take care and wipe clean with a wet cloth any excess glue that may migrate to the stained surface. When glue has set spray the stained surface with a **Clear Matte Finish** to protect the stain.

Remove two (2) of the 3/16" x 3/16" curved laser cut **Waterways** marked "G" for the **Gun Deck** and mark a 1/16" line on the top surfaces to match the side wall thickness; next mark a 1/16" line on the inboard curved side to match the thickness of the **Deck Planking**. Now angle cut the outboard surfaces to match the angle of the **Frames**. Next angle cut from the 1/16" pencil line on the top surfaces down to the 1/16" pencil line on the inboard sides. Test fit for proper fit and sand smooth. Then paint with two (2) coats of **Dark Green MS4801** and set aside to dry. Once dry Glue the **Waterways** in place and then the **Gun Deck Planking** sections as seen in the photos on the next page.



Gun Deck planking sections and waterways glued in place.



Trim top edge of Sidewalls to match the bottom edge of Frame Beams.

Gun Deck Sidewalls fitted and painted White, eyebolts installed in correct orientation vertically and horizontally then glued in place.

Locate, test fit, adjust if necessary for a tight fit then paint White the port and starboard **Gun Deck Sidewalls** and set aside to dry. Make sixteen (16) **Eyebolts** using 28 gauge black wire. Cut to length and then glued into holes in **Sidewalls** and the excess cut off on the backside of the **Sidewalls**. Note the orientation of the **Eyebolts** in the sidewalls. **Glue Gun Deck Sidewalls** in place. Trim the top edges of the **Sidewalls** to match the bottom edges of the three (3) **Frame Beams**. See Photo above.



Wire twisted around the shank of a 1/32" drill bit inverted in a pin vise. Then cut to length with snips.

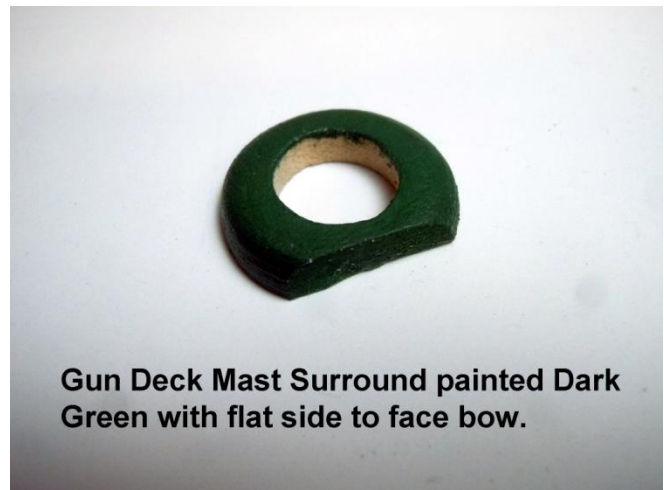

Gun Deck Mast Surround painted Dark Green with flat side to face bow.

Next, shape half round the edge of the laser cut **Mast Surround** with the flat edge and then paint it with two (2) coats of **Dark Green MS4801** and set aside to dry. **Do not** carve the flat edge, see photo above.

Assemble and paint the **Hatchway Frame** and two (2) **Steps** as described previously above for the **Berthing Deck**. Glue **Frame** and **Steps** in place to the **Gun Deck Planking** centered on the **Hatchway** opening in the **Deck Planking**. Paint **White** the remaining inside surfaces of the **Hatchway Frame** opening.

Assemble and stain two (2) **Stern Ladders** using laser cut parts as previously described for the **Berthing Deck** and once stain has dried glue in place as seen in the photo on the next page.

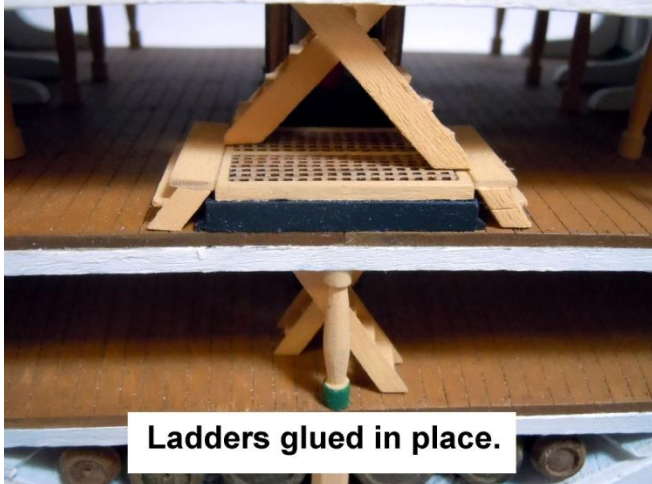

Ladders glued in place.



Pump bodies painted Copper, pump linkage and Flanges blackened.

Clean and mask linkages and lower shafts of six (6) **Pump Bodies** and six (6) **Flanges** then spray paint with primer and then Copper paint. Once completely dry remove masking and darken the linkage and lower shafts with a darkening agent or paint with Flat Black paint.

Insert two **Pump Bodies** into **Bow** end deck holes and test fit into ends of **Pipes** and trim the lower shaft ends so that the pump sit flush on the deck as seen in the picture below. Position the **Pump Bodies** as shown with correct linkage orientation and with the **Flanges** added and glued into place against the shoulder on the shaft and the lower shaft end indexed into the **Pipe** glue the **Pipe** joint first and let glue set. Next glue the **Pump Bodies** in place by adding the glue to the underside of the **Deck Planking** so as not to mar the deck topside finish. Next glue the four (4) aft **Pump Bodies** in place using the same process. See photos below and on the next page. To reach deep under the deck make a 28 gauge wire CA glue applicator and as the hook end fills with hardened glue snip it off and form another hook. See picture on next page. Water bottle tops make good CA glue holders to dip the hook end into to pick up the glue.

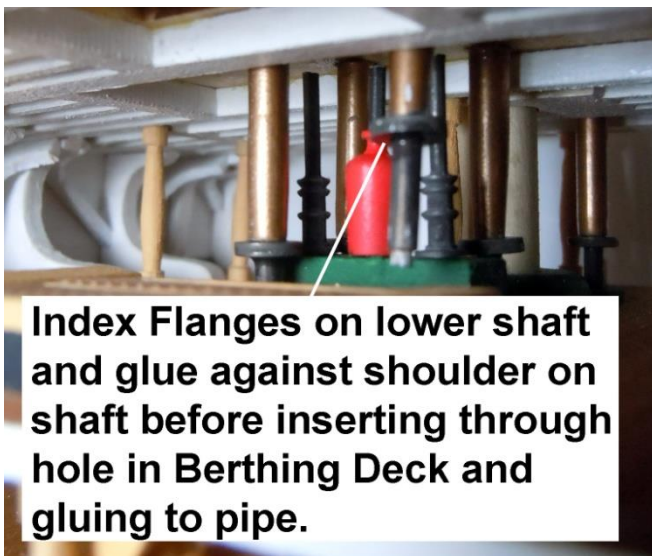

Index Flanges on lower shaft and glue against shoulder on shaft before inserting through hole in Berthing Deck and gluing to pipe.

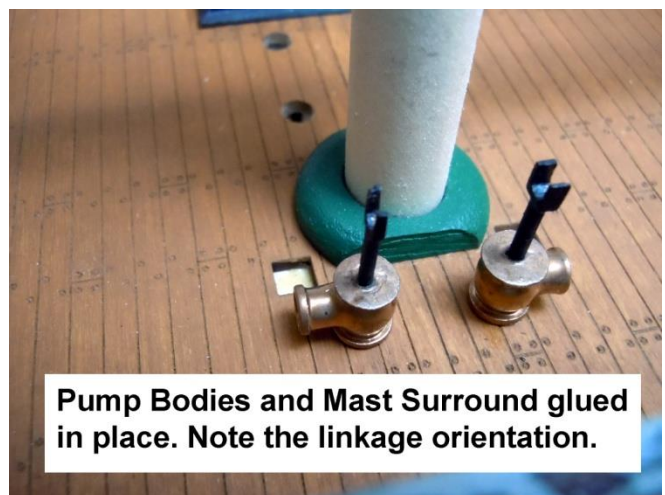

Pump Bodies and Mast Surround glued in place. Note the linkage orientation.

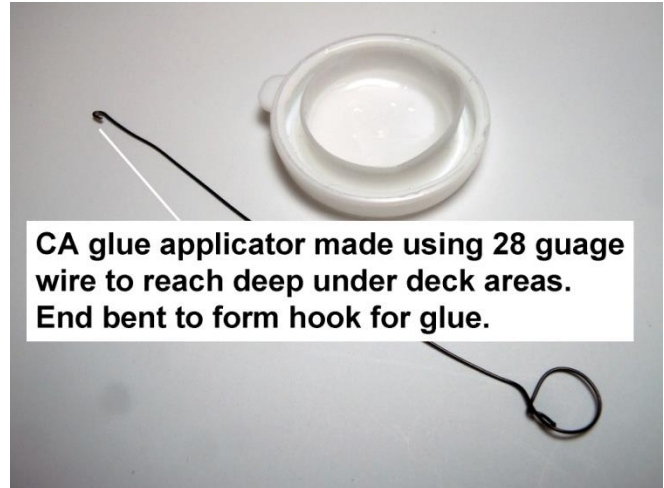
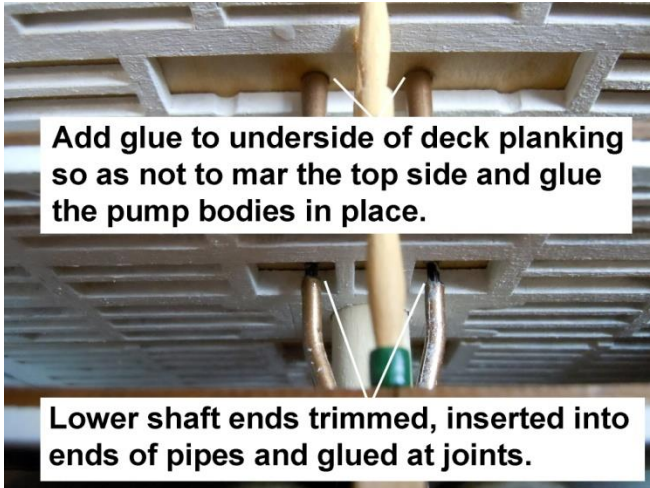

Gather the following twelve (12) **Pump Lever Arms** parts seen below and clean; file and dry fit parts for assembly. Once satisfied with part fits, darken or paint Flat Black. The two (2) **Handle** parts should have the wooden handle sections painted **Deep Brown MS4818** as seen in the photo below. Note the two (2) **Center Linkage Arms** should be trimmed to the deck surface once the **Pump** assemblies are glued in place first.

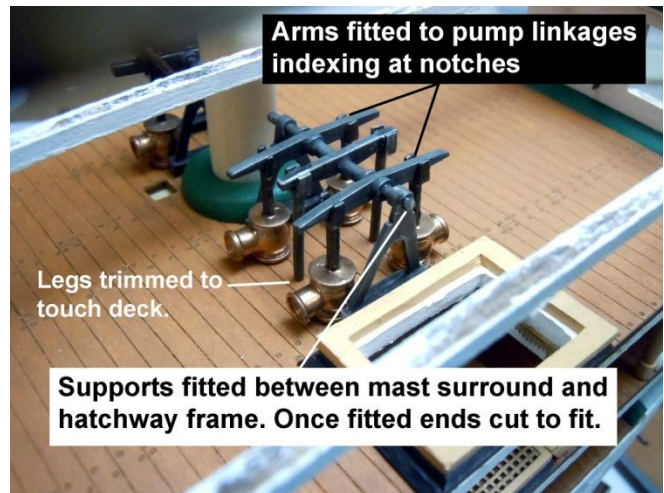
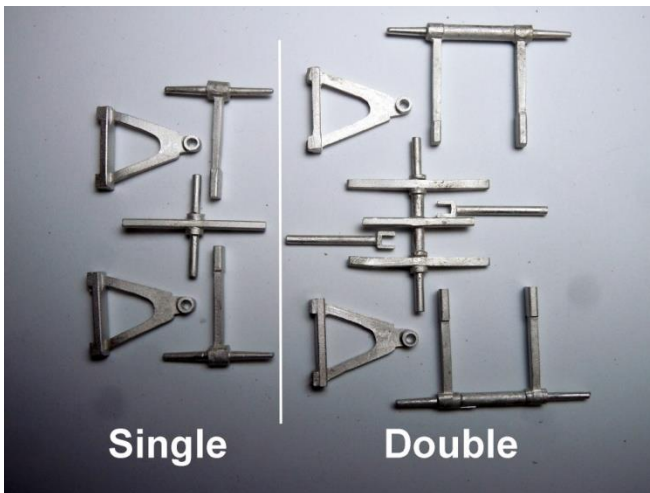

Index and glue in place into the two (2) **Copper** painted **Pump Bodies** the lever arms so that the notch on the bottom of the levers butts against the “U” tops of the **Pump Bodies**. Note that this is a tight fit between the **Mast Surround** and the **Hatchway Coaming** on the double arm unit. Once in place and the glue has set then cut and fit to the two (2) **Center Linkage Arms** and glue them in place with the “U” tops butting against the notches in the **Center Lever Arm**. Carefully glue the two (2) single and two (2) double painted **Deep Brown Handles** in place with the handle rounds indexed at the square ends of the **Lever Arms**; then once the glue has set on the first **Handle** add the second **Handle** again indexing the **Handle** rounds at the square ends of the first **Handle**. Make sure on the single **Pump Unit** that the **Handles** are clear vertically of the square holes in the deck. The **Spar Deck Bitt Arms** will index into these squares coming down from above. Test fit the **Bitts** to verify clearance. See photos on the next page.

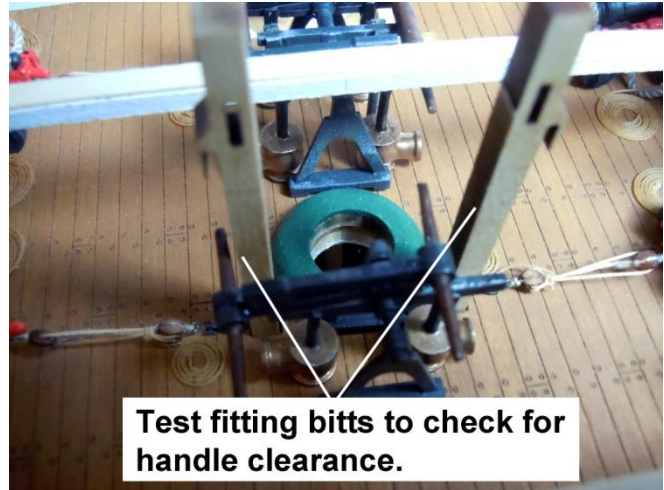

Knees: Remove and paint White twelve (12) **Hanging Knees** and eight (8) **Standard Knees** as seen in the sheet below. In a scrap wood strip drill two 1/32" holes 1/32" apart and glue with CA two (2) short brass rods in the holes and let set. With a length of 28 gauge Black wire laying lengthwise on the wood strip below the rods wrap one end around and in between the two rods then repeat with the other end of the wire. Grip the two ends of the wires with a small flat nose pliers twist the wire together tightly as seen on the next page. Cut the ends off resulting in a **Double Eyebolt**.

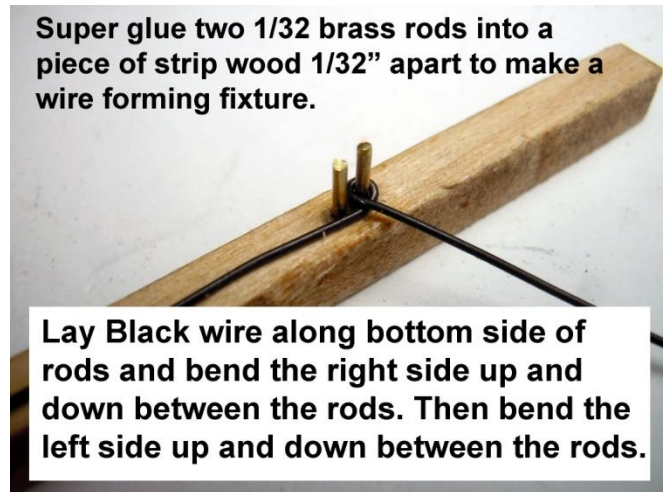
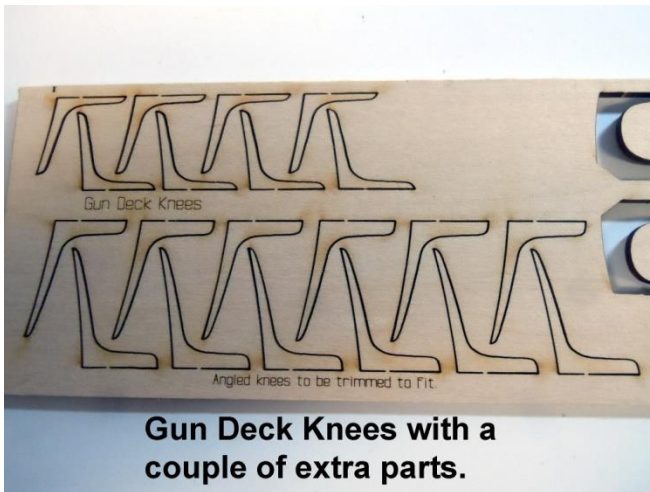

Make six (6) **Double Eyebolts**. Very carefully drill holes in the short leg of the **Standard Knees** 1/16" up from the bottom edge. Insert and glue the **Double Eyes** into the holes and cut off excess twisted wire smooth to the backside of the leg as seen in the photo on the next page. Glue the middle **Standard Knee** centered between the gun ports openings with the top edge flush with the top edge of the **Sidewalls**. Now measure the distance from the edge of the **Knee** to the gun port opening and use this dimension to determine the locations of the other **Standard Knees** relative to the gun ports. See photos on the next page.

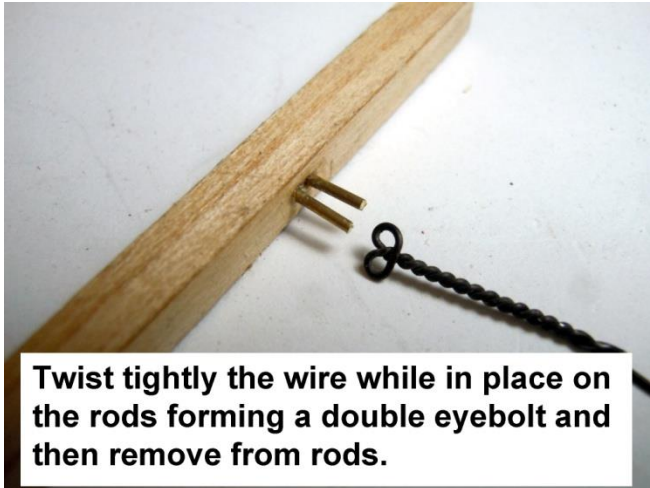

Twist tightly the wire while in place on the rods forming a double eyebolt and then remove from rods.

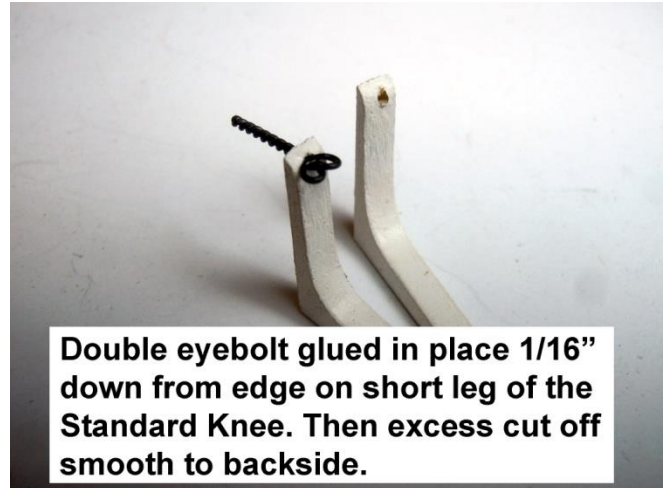

Double eyebolt glued in place 1/16" down from edge on short leg of the Standard Knee. Then excess cut off smooth to backside.

The **Diagonal Knees** will need more careful effort in cutting and locating between the **Standard Knees** and a couple of extra **Knees** are supplied just in case. Start with the center **Standard Knee** and cut the bottom of the longer leg at an angle to match the **Standard Knee** about a 1/16" above the bottom edge of the **Standard Knee** leg with the **Diagonal Knee** angled towards the gun port with the corner of the long (upper) leg aligned with the top edge of the **Sidewall**. Hold the **Knee** in position and mark the angle to be cut using the top edge of the **Sidewall** as a guide. Test fit making adjustments as needed for a tight fit against the **Standard Knee** and the angle cut on the long leg following the direction of the **Frame Beams**. Glue **Diagonal Knee** in place when satisfied with fit. Repeat steps for the balance of the **Diagonal Knees**. At the bow only the lower portion of the leg will be used. See photos below.

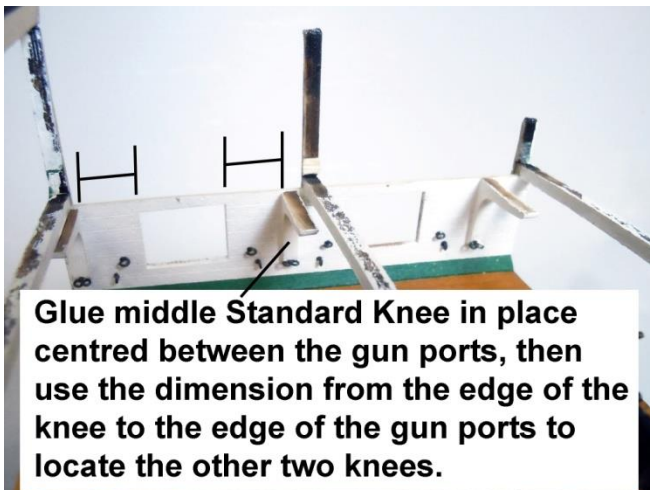

Glue middle Standard Knee in place centred between the gun ports, then use the dimension from the edge of the knee to the edge of the gun ports to locate the other two knees.

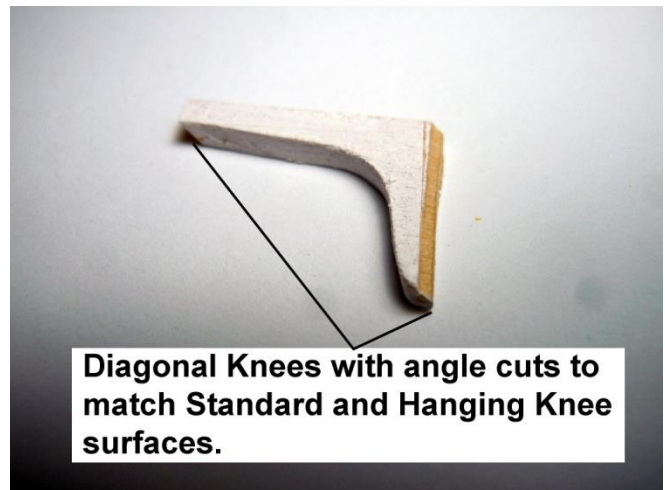

Diagonal Knees with angle cuts to match Standard and Hanging Knee surfaces.

Removal of the top bow and middle **Frame Braces** will provide more working accessibility, but take care not to break off the **Spar Deck Frame** extensions. If broken off glue back in place immediately to avoid the part being lost in the abyss of lost parts.



Long Guns: Gather the **Long Gun** laser cut **Carriage** parts; **Wheels** large and small; **Cast Barrels** and 3/32" x 3/32" wood strip as see in the photo above. Assemble the **Carriage** parts by gluing the **Platform** to one **Side** aligning the bottom edge of the **Platform** with the top edges of the wheel axle notches then glue the center **Brace** to the **Platform** and **Side** centered on the half round cut and then add the second **Side**. See in the photos below.

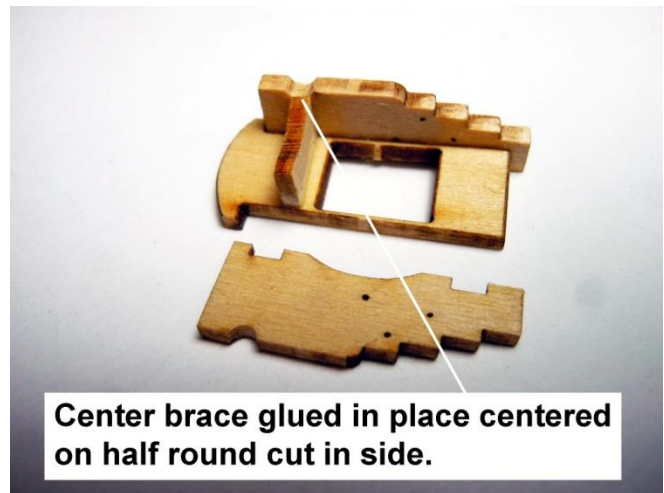
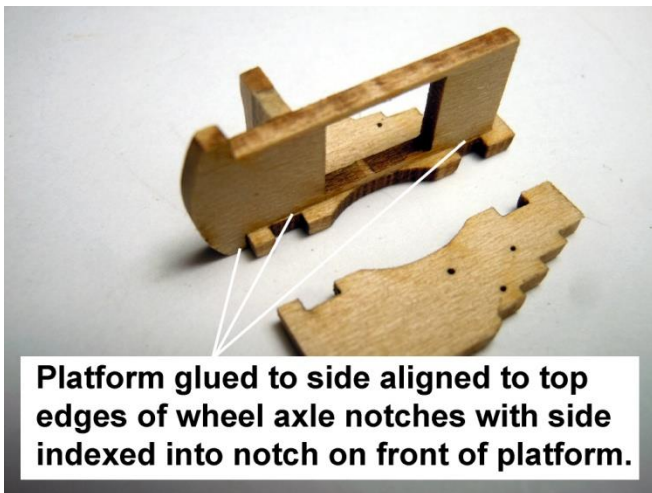

Cut eight (8) pieces of the 3/32" x 3/32" x 3/4" for the **Gun Carriage Axles** and mark a pencil line 1/8" down from each end and then score with a sharp hobby knife to carve the ends round. Next plunge cut the end corners to the scribe line and trim to round. Now with a small needle file carefully round the ends to press fit the wheel axle holes. As seen in photo on the next page. Once all eight (8) **Axles** are completed glue them into the notches making sure that they are centered left to right. Paint all assembled **Carriages Gun Carriage Red MS4802**. Sand the perimeters of all the wheels large and small smooth and paint **Hull Spar Black MS4830** and then glue in place and paint the ends of the **Axles** Black. Next make twenty (20) wire **Single Eyebolts** and add 1/8" **Split Rings MS0955** to eight (8) then darken or paint Black the **Split Rings**. Next drill 1/32" holes at all eyebolt locations as seen in the photo on the next page. Note that the side locations have laser cut starter holes while the fifth location at the rear of the platform will have to be drill completely on center between the sides. Paint the four (4) **Quoins** Red. Clean and file smooth the **Cannon** and **Carronade Barrels** then darken or spray paint Satin Black.

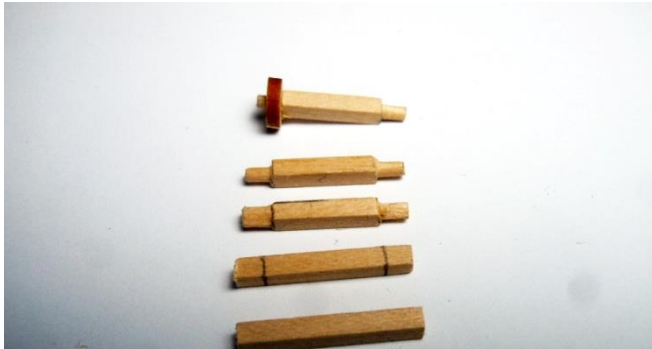

3/4" lengths marked 1/8" in from ends, scored with knife around perimeter, cut back on corners then sides and finally filed round to fit wheel.



Finished axles glued in place.

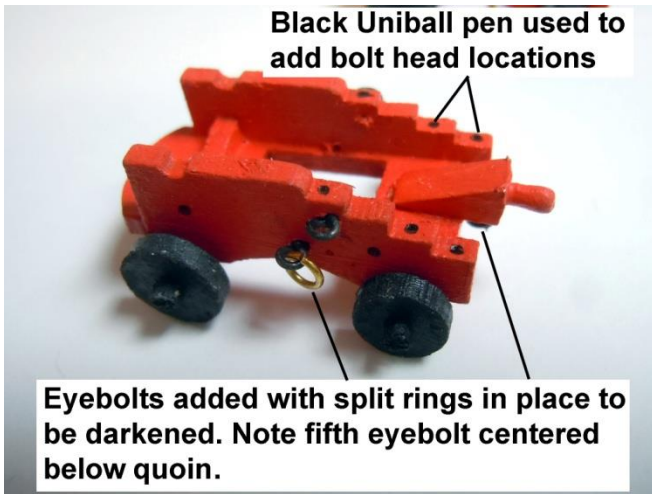

Black Uniball pen used to add bolt head locations

Eyebolts added with split rings in place to be darkened. Note fifth eyebolt centered below quoin.

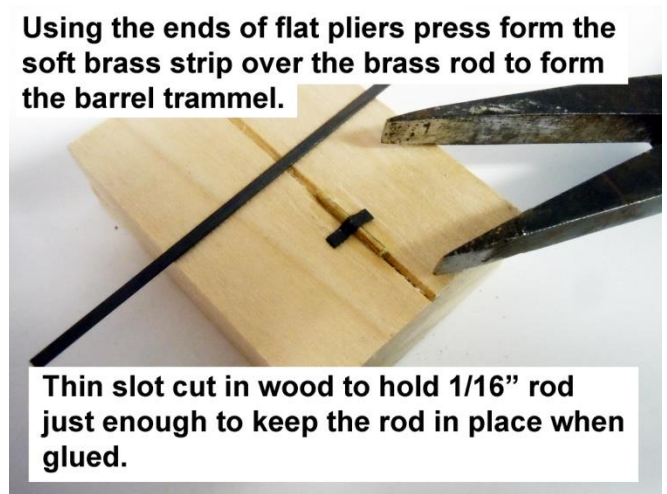

Using the ends of flat pliers press form the soft brass strip over the brass rod to form the barrel trammel.

Thin slot cut in wood to hold 1/16" rod just enough to keep the rod in place when glued.



Assembled long gun ready for rigging with quoin just set in place.

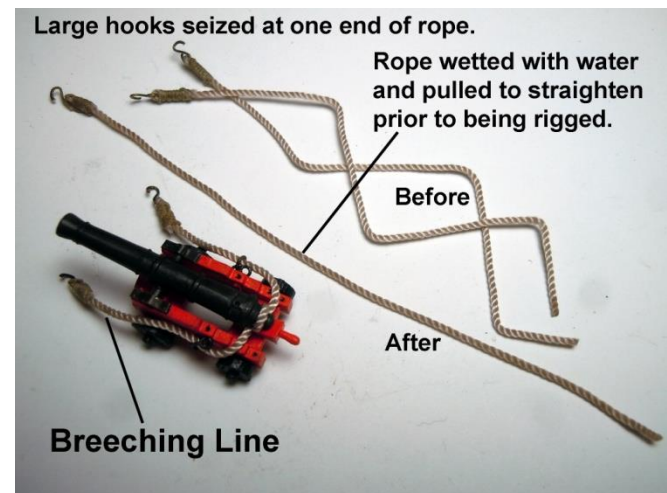

Large hooks seized at one end of rope.

Rope wetted with water and pulled to straighten prior to being rigged.

Before

After

Breaching Line

Now using the darkened 1/16" soft brass strip form eight (8) **Trammels** for the **Barrels** using small flat pliers and trim to fit on the **Carriage**. Set the **Barrel Trunnions** in the half round locations and carefully

glue the **Trammels** in place without gluing the **Barrel Trunnions** so that they can be adjusted later in the gun ports and then finally glued permanently using the **Quoins**.

Rigging the Long Guns: Cut four (4) 6" lengths of **.040" Beige Line (1244)**. Seize a large **Hook** to one end using **.008" Beige Thread (1241)** as seen in the picture on the previous page. **TIP:** *Any kinks can easily removed by wetting rigging lines with clean water and then stretch/pull the line and let dry.* Feed the end without the **Hook** through the left **Split Ring** and align the **Hook** with the end of the **Barrel**, now wrap the line around the butt (end) of the **Barrel** and then through the right **Split Ring**. Now seize the second **Hook** to the line again aligned with the butt (end) of the **Barrel**. This forms the **Breeching Line**, complete rigging the three (3) remaining **Long Guns** with the **Breeching Lines** as seen in the picture below.

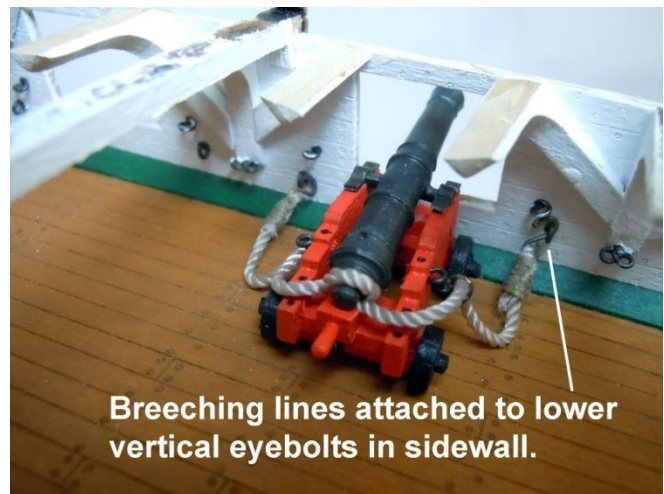

Position the **Long Guns** centered in the gun ports, engage the **Breeching Line Hooks** into the lower vertical eyebolts in the sidewalls. Position the **Gun Barrels** centered vertically in the gun ports using the **Quoins** and once they are in position glue them in place. Next add a touch of medium CA to the front edge of the **Long Gun Sleds** and then glue to sidewalls making sure **Guns** are centered in the gun ports and the back edge is parallel to joint lines in the deck when looking down. See photo above.

Next make a rigging fixture to seize **Blocks and Hooks** by drilling two **.020"** holes at least a **1/4"** deep in the end of a strip of **1/4" x 1/4" x 5"** spaced apart as the **3mm Block** holes as seen in photo on the next page, insert two short rods into holes with one slightly longer for ease of adding the **Blocks** and glue them in place and also harden the top of the wooden strip with CA glue. This fixture will be used for stopping many **Blocks** throughout the build process, and being clamped in a small vise will be at an easy height off the work table to work with. A spring clamp will be used to hold lines in place as they are rigged.

The typical process to strop a **Block** with a **Hook** is to tie with **Beige thread (1242)** a **Hook** through the small hole then form a tying loop with the thread and with the line clamped to the fixture bring the loop down over the end of the line and seize with **Beige (1241)** a square knot on the back of the **Block** with the **Hook** on the front of the **Block**. Next using a small spring clamp secure the two ends of the line and the short end of the thread, once secured use the long end of the thread to tie off the lines with half hitches for about **1/16"**. Carefully with CA touch the knot to glue the ends of the thread and the short end of the line so that they can be cut off at the knot with small scissors. Take care **not to glue** the

block to the **Brass Rods**. Once the line and thread ends are cut remove the block and repeat for as many **Single** (12) and **Double** (12) **Blocks** that are needed to secure the **Long Guns**. Index and feed the **Single Block** line through one hole in the **Double Block** and then back through the **Single Block** then back through the **Double Block** and cinch up lines to about 3/4" between **Blocks** as seen in the photo below. Repeat for all necessary rigging sets needed eight (8) **Gun Tackles** and four (4) **Train Tackles**.

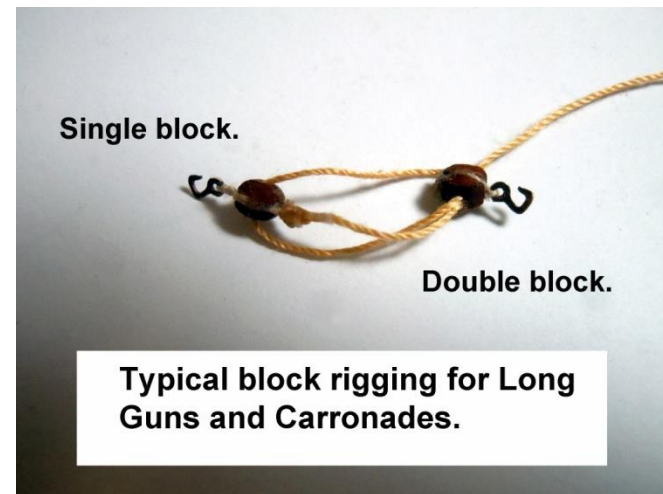
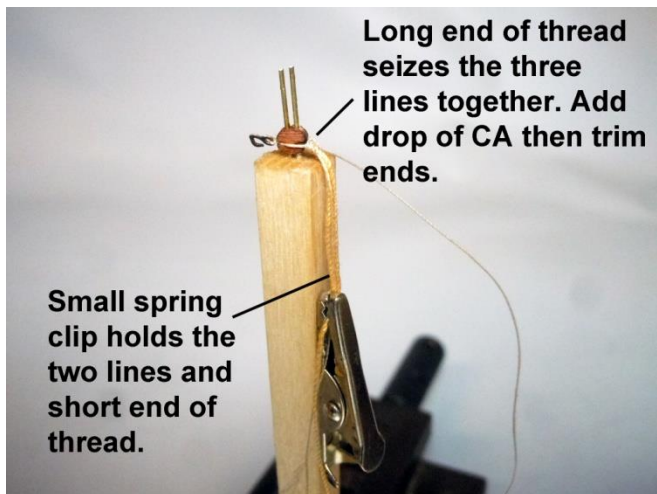
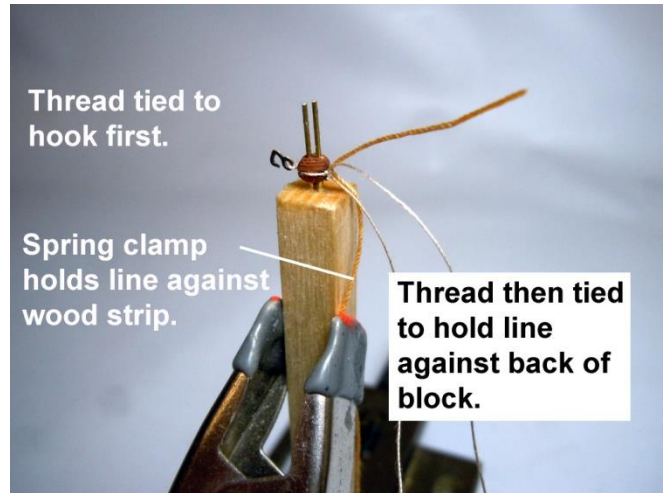
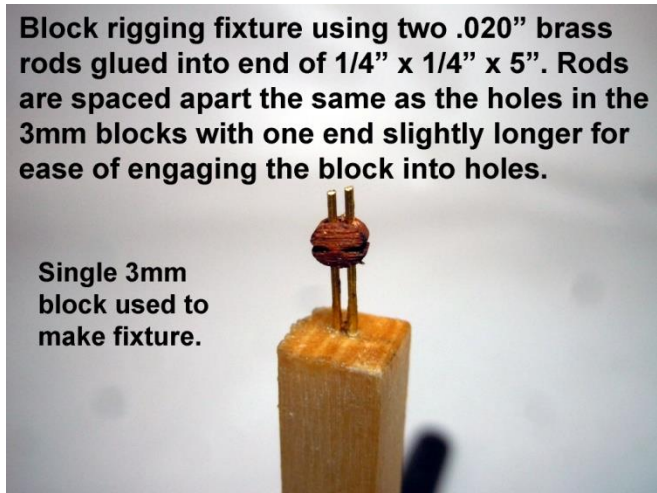

Add the **Train Tackle** lines first indexing the hooks of the **Single Blocks** into the **Eyebolts** on the back of the **Carriages** below the **Quoins** and then the **Double Blocks** hook to the **Eyebolt** inserted into the holes located on the deck as seen on the next page. Next add the **Gun Tackles** indexing the hooks of the **Single Blocks** into the **Eyebolt** on the sides of the **Gun Carriages** and then hook the **Double Blocks** to the **Double Eyebolts** on the side walls and cinch up the lines until taught then secure the line with two (2) half hitches just aft of the **Double Block** and add a small drop of 50/50 mix of White Glue and water to the hitches and let the glue mix set. Once the glue mix has set and cut the excess line off at the hitches. **Rope Coils** are optional and require patience to make. On a plastic container lid at a small puddle of 50/50 white glue mix and drag a 6" length of **Rope Line (1242)** that one end has been glued with CA and then trimmed very close to the end of the glued rope through the puddle slowly to soak the line. Using spring loaded tweezers seize the glued end and twirl into a circle to the desired

size. This may take several times to get the feel of doing. Undoing the twirl will help if the rope rides up or under the **Coil** when forming and a second set of regular tweezers will also help with forming and adjusting the **Coil**. Keep the tips/ends of the tweezers clean. The objective is to have a small opening in the center of the flat **Coil** and once formed excess glue in the center can be removed using a damp Q-tip (cotton bud). Let **Coil** set until dry, while drying some shrinkage may occur based upon the line used just moisten with water and tighten the **Coil** slowly and carefully with tweezers. Note that there are left and right **Coils** needed and smaller **Coils** for the **Train Tackle**.

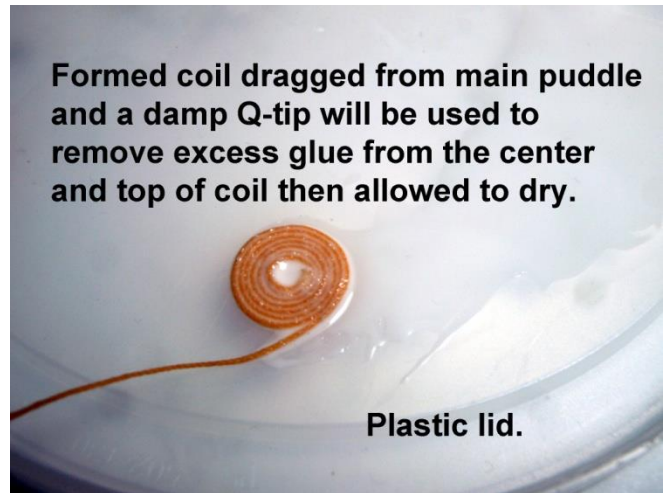
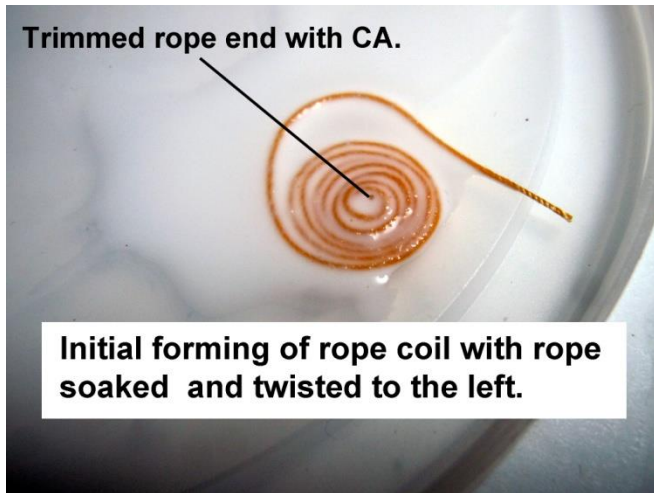

Once **Coils** are dry remove from plastic lid adjust and trim the rope end so that when the **Rope Coils** sits flat on the deck it indexes to where the hitches are to look like an extension of that knot.



Next paint the two (2) **Spar Deck Frame Structure** sections White except for the upper gluing surface for the decking sections as done on previous decks. Once dry, insert and center the **Fore Frame Structure** section in place between the **Frame Beams** position the **Mast Fixture** then clamp in place for tight fits against the **Frame Beams'** top edges of **Sidewalls** and the top surfaces of the **Knees**. Check and trim any **Knee** surfaces that may be too high. Once satisfied with test fit then glue in place. Repeat and glue in place the **Aft Frame Structure** section following the same procedure of positioning and gluing.

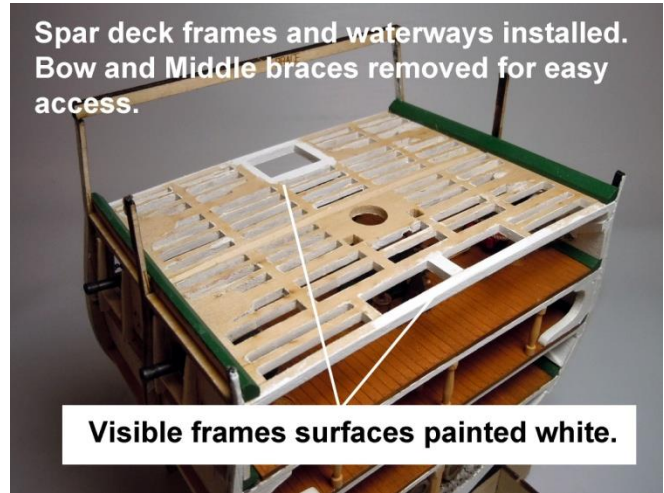
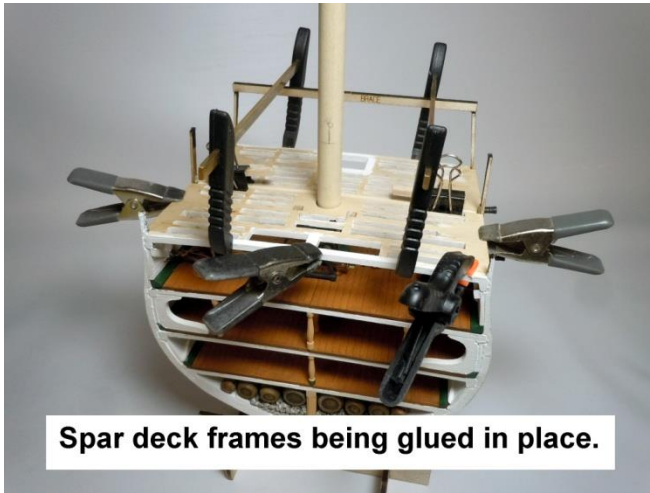

SPAR DECK:

Locate the **Spar Deck Planking** sections (2) and apply a stain coat of **English Oak Stain MS4975**. Once the stain has dried then glue the two (2) sections together; take care and wipe clean with a wet cloth any excess glue that may migrate to the stained surface. When glue has set spray the stained surface with a **Clear Matte Finish** to protect the stain.

Assemble and paint the laser cut **Hatchway Frame** and two (2) **Steps** as described previously above for the **Gun Deck**. **Do not paint fill** the laser cut holes for the canopy, if painted shut, drill open. Glue **Frame** and **Steps** in place to the **Gun Deck Planking** centered on the **Hatchway** opening in the **Deck Planking**. Paint **White** the remaining inside surfaces of the **Hatchway Frame** opening.

Locate and Natural stain the laser cut **Upper Main Hatch** (1) and paint the **Lower Main Hatch Frame** (1) Black. Assemble the bow **Main Hatch Frame** by gluing the stained **Upper Frame** centered on the top surface of the **Lower Frame**. Once the **Frame** is assembled, glue the **Main Hatch Frame** to the **Deck Sections** as seen in the photo seen on the next page.

Remove two (2) of the 3/16" x 3/16" slightly curved laser cut **Waterways** marked "S" for the **Spar Deck** and mark a 1/16" line on the top surfaces to match the side wall thickness; next mark a 1/16" line on the inboard curved side to match the thickness of the **Deck Planking**. Now angle cut the outboard surfaces to match the angle of the **Frames**. Next angle cut from the 1/16" pencil line on the top surfaces down to the 1/16" pencil line on the inboard sides. Test fit for proper fit and sand smooth. Then paint with two (2) coats of **Dark Green MS4801** and set aside to dry. Once dry glue the **Waterways** in place and then the **Spar Deck Planking** sections as seen in the photos on the next page using the **Mast Fixture** and the

two (2) Natural stained **Bits** inserted (**do not glue**) through the **Spar Deck** square holes and indexed into the square locations in the **Gun Deck**.

Assemble and stain two (2) **Stern Ladders** and two (2) *longer* **Bow Ladders** using laser cut parts as previously described for the **Berthing Deck** and once stain has dried glue in place as seen in the photo below. The **Stern Ladders** are installed as done on previous decks.

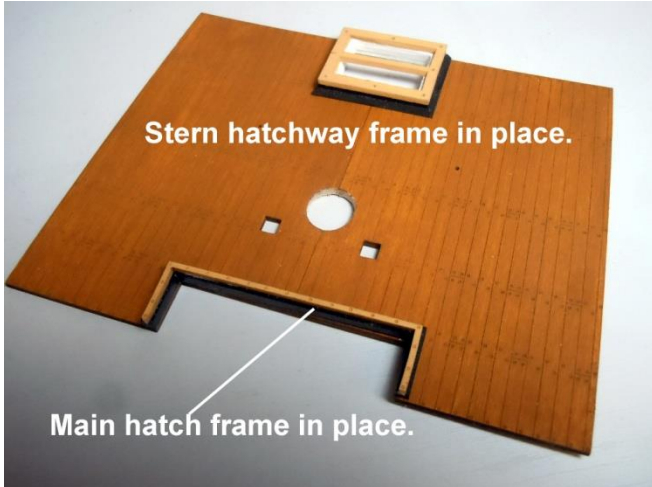

Stern hatchway frame in place.

Main hatch frame in place.

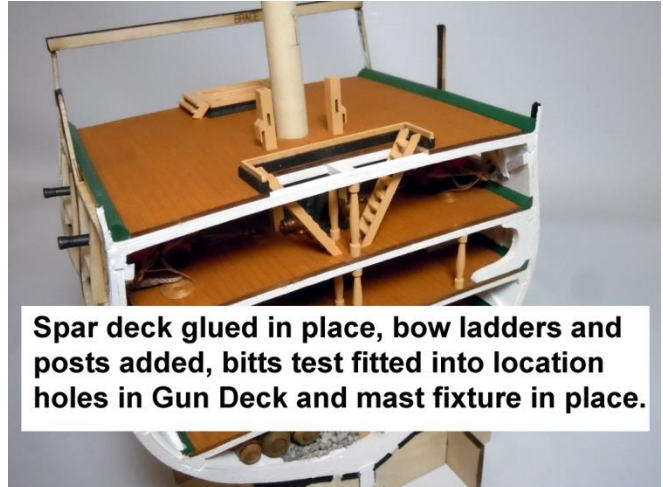

Spar deck glued in place, bow ladders and posts added, bits test fitted into location holes in Gun Deck and mast fixture in place.

Locate and glue in place the **Gun Port Braces** making sure that they are flush with the edges of the **Gun Port** openings. Then add the laser cut **Bottom Braces** fit between the side **Braces** at the bottom of the **Gun Ports**. These bottom parts should be installed parallel to the ground. Once glue has set, lightly sand these **Braces** to be faired/flush with the **Hull Frames** as seen in picture below.

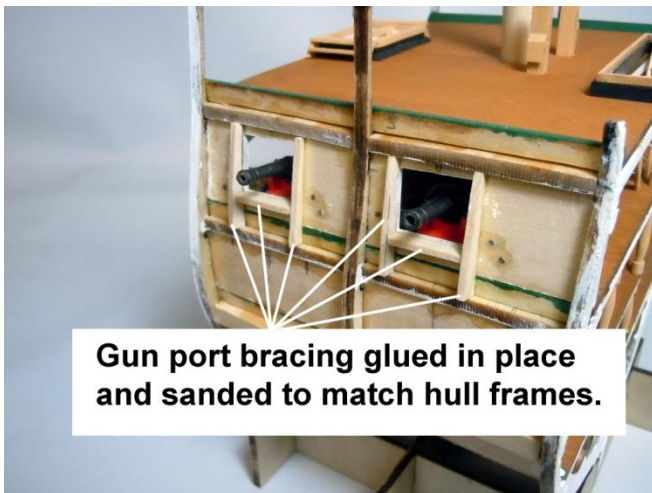

Gun port bracing glued in place and sanded to match hull frames.

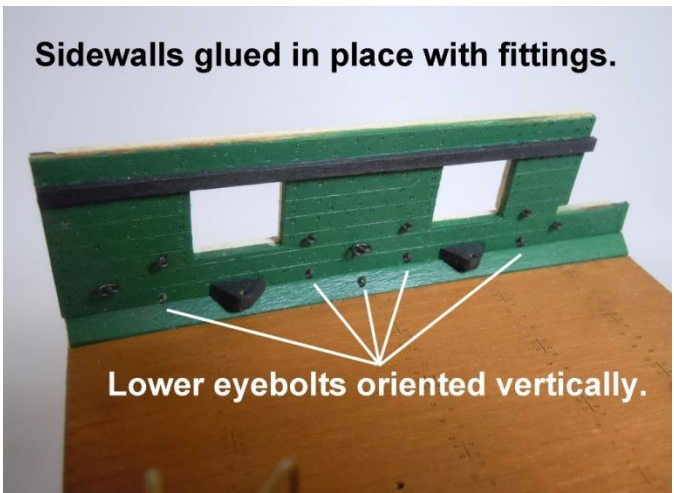

Sidewalls glued in place with fittings.

Lower eyebolts oriented vertically.

Spar Deck Sidewalls. Paint both port and starboard **Spar Deck Sidewalls Dark Green MS4801** and **do not paint** fill the laser cut location holes for fittings. When paint is dry locate and glue **Sidewalls** in place tight against the **Waterways** and flush fore and aft with the **Hull Frames**. Cut and paint black two (2) **Gun Port Trim** using 1/16" x 3/32" x 4" wood strips. Glue in place flush across the top edge of the **Gun Port** opening as seen in the picture above. Locate the four (4) **Carronade Pivoting Bases** and using the center laser cut reference lines drill a 1/32" holes for a 1/32" **Brass Rod** locating pins. Cut short brass pins and glue into holes. Then paint black and when dry glue into the laser cut location holes as seen on previous page. Locate the two (2) **Cleats** and four (4) **Pin Rails** drill 1/32" holes for

locating pins and glue pins in place. Stain **Cleats** and **Pin Rails Natural MS4972** and when dry glue in place using laser cut location holes as seen on previous page. Next make four (4) **Double Eyebolts** and twenty (20) **Single Eyebolts** as described earlier. Glue the four (4) **Double Eyebolts** in place on Port and **Starboard Sidewalls** ream or drill the holes if needing enlargement. Next glue five (5) **Single Eyebolts** in place oriented **horizontally** on either side of the gun ports and below the **Sea Step** opening. Now glue four (4) **Single Eyebolts** oriented **vertically** on either side of the gun ports just above the **Waterway**. With a 1/32" drill bit drill a hole in the center of the **Waterway** directly below the middle **Double Eyebolt** and glue a **Single Eyebolt** vertically in the hole. Now on the backside of the **Sidewalls** cut/trim all **Eyebolt ends** and **Brass Rods** flush with the wall surface and add a drop of medium CA to make sure all are secure.

Carronades: Gather all the necessary laser cut parts (24) and cast parts (12) as seen in the picture below. Assemble the four (4) **Carriages** gluing the **Brace** to the **Base**; add the two (2) sides to the outer edges of the **Base** aligned flush front to rear; glue the **Sled Guide** to the **Base** centered across the bottom of the **Base** and flush front to rear. See picture below.

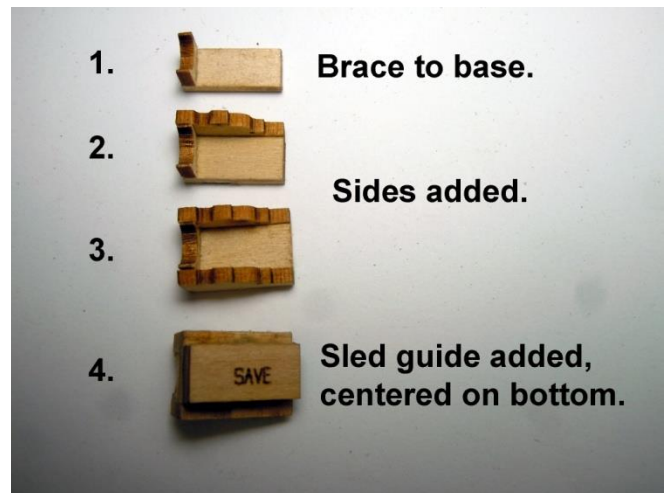
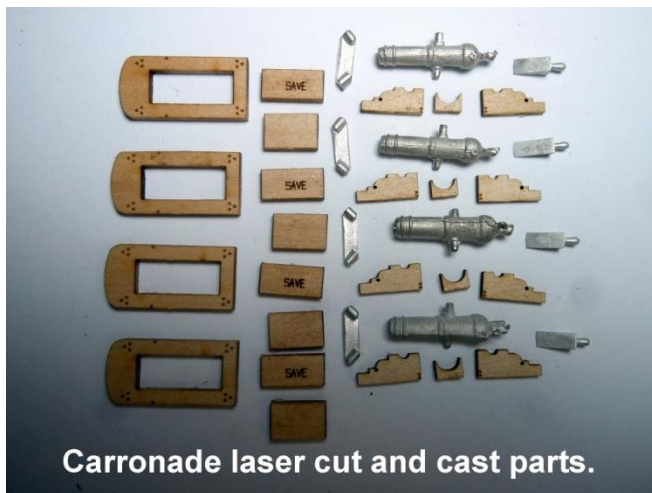

Locate and drill all holes needed for the eyebolts in both the **Carriages** and the **Sleds** as seen in the picture on the next page. Glue the **Carriages** into the openings in the **Sleds** to the front edges of the openings. Cut four (4) pieces of 1/32" brass rod and glue them into the forward holes on the underside of the **Sled**. These are the **Pivoting Pins** that will index into the **Pivoting Bases** located in the sidewalls. Now glue the cast **Wheels Assemblies** to the rear edge of the underside of the **Sled** paying attention to the direction of the angled wheels. Paint black or darken the **Wheels** only; then paint the **Carriages**, **Gun Carriage Red (MS4802)** and the support bracket between the **Wheels**. **Do not paint** the brass pins. Next make twenty (20) **Single Eyebolts** and glue them into the location holes drilled previously. While waiting for paint to dry clean and file as necessary the cast **Carronade Barrels** and paint black or darken. Clean and paint the four (4) **Quoins** red. Make eight (8) **Trunnions Brackets** as described previously using the soft brass strip and paint them black or darken. Set and center the **Barrels** in the **Carriages** and carefully glue the **Trunnions Brackets** in place trying not to glue the **Barrels**. Test fit the **Pivoting Pins** into the **Pivoting Bases** making sure that the **Carronade Wheels** touch the deck and if not, carefully bend slightly the pin to attain touching. Once satisfied with fit, set **Carronades** in place and glue aligning the rear edges parallel to the deck joint lines.

Using **Single** and **Double Blocks** and **Hooks** rig twenty (20) **Tackle** lines as previously described for the **Long Guns**. Read ahead and study pictures of the rigging procedures about to be completed.

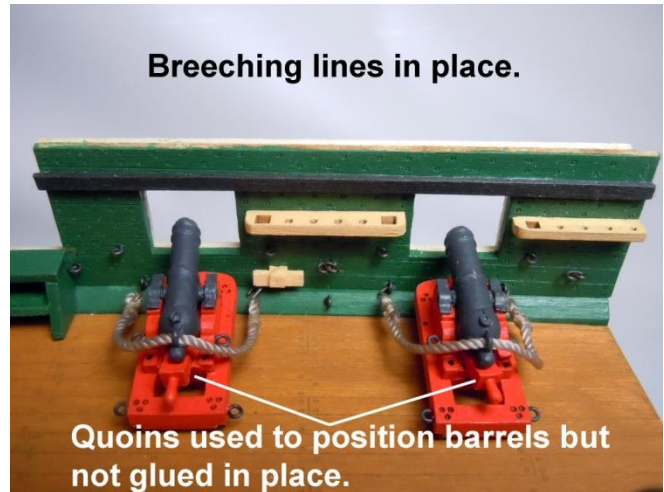
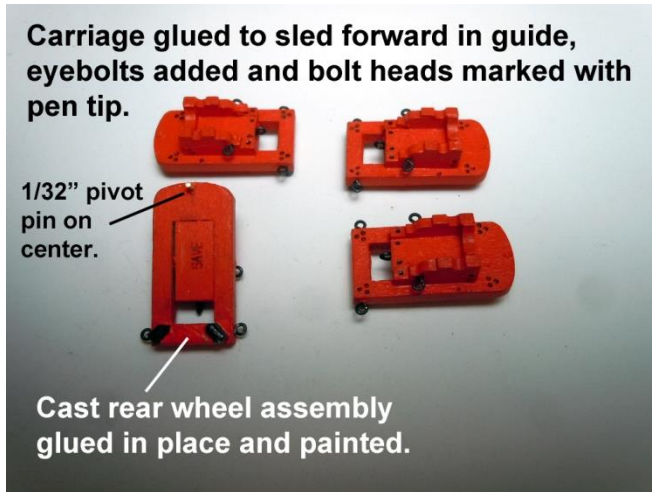

Rig the **Beige Breaching Lines (1244)** with **Hooks** seized to one end of lines then passed through the rings at the end of the **Barrels** then second **Hooks** seized to the ends of the line. The length of the line is determined as if hooked to the **Sidewall** and the **Carriage** all the way to the rear of the **Sled**. Note **Quoins** are used to position the **Barrels** within the gun ports, but **not glued** in place yet.

Make four (4) **Single Eyebolts** and glue them in place on the deck for the **Train Tackle** as seen in the picture above straight behind the **Carronade**. Remove the **Quoin** and engage a **Single Block Hook** into the eyebolt at the rear of the **Carriage** then engage the **Double Block Hook** to the eyebolt in the deck forming the **Train Tackle**. Seize the line at the **Double Block** and add a drop of mixed glue at the knot. Trim excess line when dry. Repeat for all **Carronades**.

With eight (8) rigged **Tackle** lines (1242) add the **Carriage Tackle** lines (1242) by engaging **Single Block Hooks** into the eyebolts at the upper rear of the **Carriage** and then the **Double Block Hooks** to the upper eyebolt next to the gun port and adjust until taut. Seize with half hitches at **Double Blocks** and trammel (wrap) the excess rope around the lines back to the **Single Blocks** and seize and add drops of mixed glue at the knots. Trim excess line when dry. Note it is easier to trammel the lines without the **Sled Tackle** in place. See picture on next page.

With eight (8) rigged **Tackle** Lines add the **Sled Tackle** lines by engaging **Single Block Hooks** into the **Double** eyebolts and (**Single** eyebolt next to steps) and then the **Double Block Hooks** into the aft eyebolts on the sides of the **Sleds** and adjust until taut. Seize with half hitches at **Double Blocks** and add a drop of mixed glue at the knot. Trim excess line when dry.

Make eight (8) large **Coils** and four (4) smaller **Coils**. When dry, glue to deck locations with line ends glued to knots to look like a continuous rope. Note the **Train Tackle** locations so as not to interfere with **Ammo Passing Scuttles**. See picture on the next page.

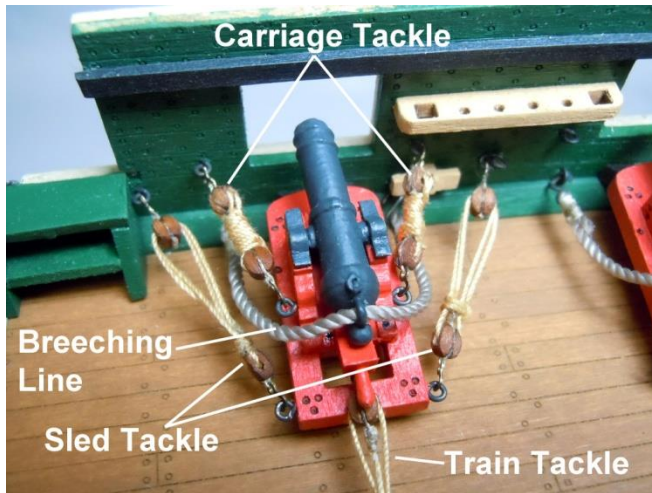

Bitt Posts: Remove two (2) **Bitt Posts** and sand all surfaces to remove laser cut char. Drill .020" holes one centered on the **Sheave Slot** the other centered on the raised surface of the **Cheek Sheave**. When drilling the **Cheek** surface slip a scrap shim into the slot to support the part being drilled to reduce chances of breaking. Insert four (4) **#8 Pins** into drilled holes, glue and cut off the excess sticking out the other side. As seen in the picture below. Next drill/cut a rectangular hole 1/16" x 3/32"; 1/16" down from the top edge of the **Bitt Post**. Cut two pieces of strip 1/16" x 3/32" x 1/2" and insert centered in the cut hole and glue in place. Stain both **Posts** Natural and when stain has dried, place a pieces of **Copper Foil** on the top surfaces of the **Posts** and trim to the edges. Insert **Posts** into square holes on **Spar Deck** with bottoms indexed into square holes on **Gun Deck** with a drop of glue on the bottom of the post surface to glue them in place. Check plans for orientation into square holes.

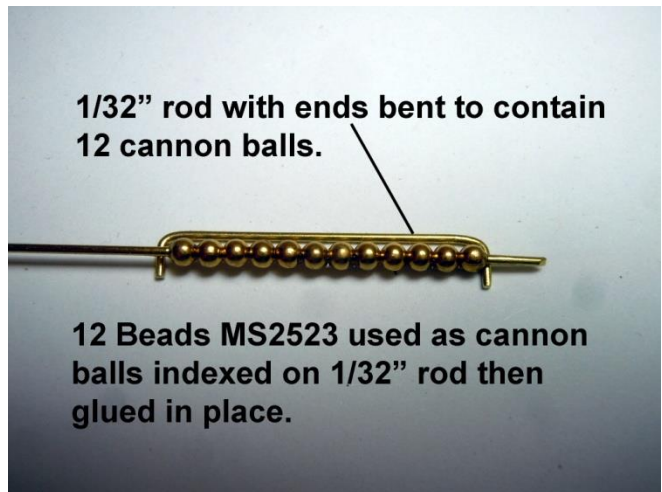

Cannon Ball Rack: Index twelve (12) **Cannon Balls** (Beads MS2523) onto a length of 1/32" brass rod and glue the end **Cannon Balls** in place as seen in picture above. Cut and file smooth the ends. Bend a length of 1/32" **Brass Rod** to match the length of the 12 **Cannon Balls**. Using the bent **Cannon Ball Rack** as a guide, drill .040" holes into the **Black Hatchway Frame** as seen in the picture below to receive the bent ends. Prime and spray paint Satin Black or brush paint using Iron **Cannon Black MS4828** the **Cannon Balls**. Darken or paint Black the bent **Cannon Ball Rack**. Once paint has set index the **Cannon Ball Rack** into the end holes and set the length of **Cannon Balls** in place and adjust

the **Rack** so that the **Cannon Balls** set just above center then carefully glue both the **Cannon Balls** and **Rack** in place. See picture below.

Remove the two (2) laser cut **Spar Deck Mast Surrounds** then carve and sand the top edges half round as seen in the picture below, glue the smaller on top aligning the center holes and then paint White. **Do not glue** in place until using final **Mast** is built

Prime and spray paint **Gold** the two (2) cast metal **Ammo Scuttles MS7816** and glue into the 3/32" hole locations on the **Spar Deck** as seen in the photo below.

Make nine (9) **Single Eyebolts** as previously described and paint white. Glue in place into the location holes around the **Main Mast** location hole with all **Eyebolt openings** facing port to starboard as seen in the picture below.

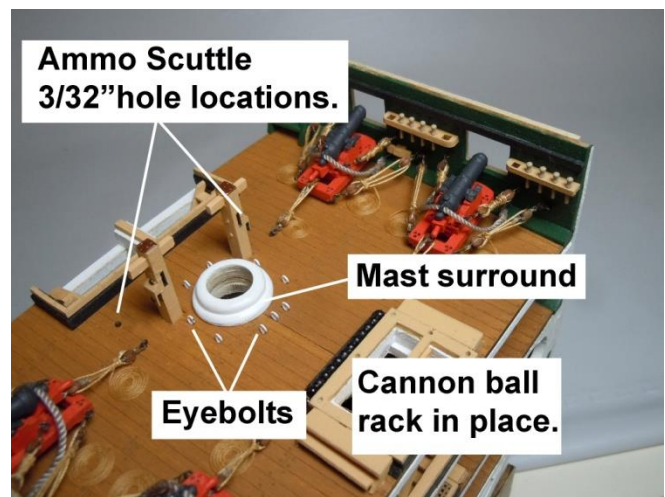
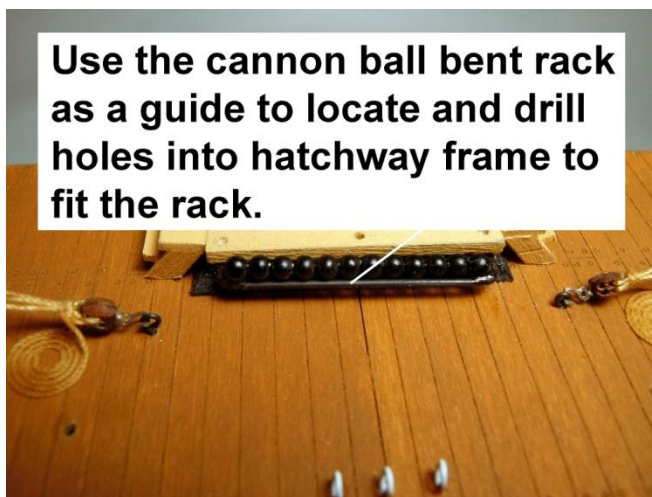

Fife Rail - Remove five (5) **Fife Rail Stanchions** and with a sharp hobby blade carefully cut and file the center section round as seen in picture above. Note one (1) extra is supplied with kit just in case. Once all are carved, filed/sanded smooth stain them with Natural Stain.

Locate the **Fife Rail** and remove from carrier sheet. Due to the small size and holes in this part the two (2) arms are subject to breaking due to the wood grain orientation so it is recommended to harden them by adding CA to all the edges. Mark the center across the rear section to locate the center **Stanchion**. Then place the **Fife Rail** on the **Spar Deck** aligning the center mark on the center joint of the deck planks next to the location holes in the **Spar Deck** and mark the location of the two holes on the **Fife Rail**. Glue the center **Stanchion** in place on the **Fife Rail** centered on the center mark. Next glue the **Stanchions** in place, centered on the end of the two arms. Now glue the two (2) outboard **Stanchions** in place centered on the hole location marks. Allow the glue to set on all the **Stanchions**. Stain **Fife Rail** with Natural Stain taking care not to fill the **Belaying Pin** holes.

Cut two (2) 3/16" long 1/32" brass rods and hammer one end flat using a small drift punch to be inserted into the center slot and centered on the bottom surface of the **Stanchions**. Test fit pins and file to adjust fit into slot then glue in place with CA and once set cut end to 1/16" long. See picture on the next page.



Fife rail stanchions carved round in center section.

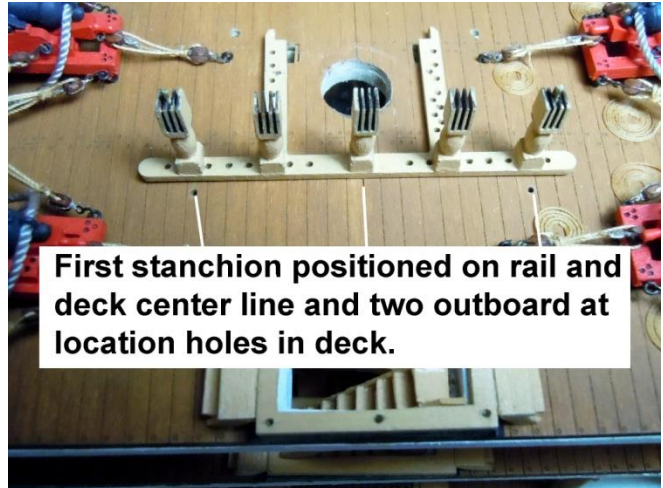

First stanchion positioned on rail and deck center line and two outboard at location holes in deck.

Carefully insert **Pins** into location holes in the **Deck**, Take care indexing the notches at the end of the arms around the **Bitt Posts** and set the arms level with the **Deck** and glue the notches to the **Bitt Posts**. See pictures below.

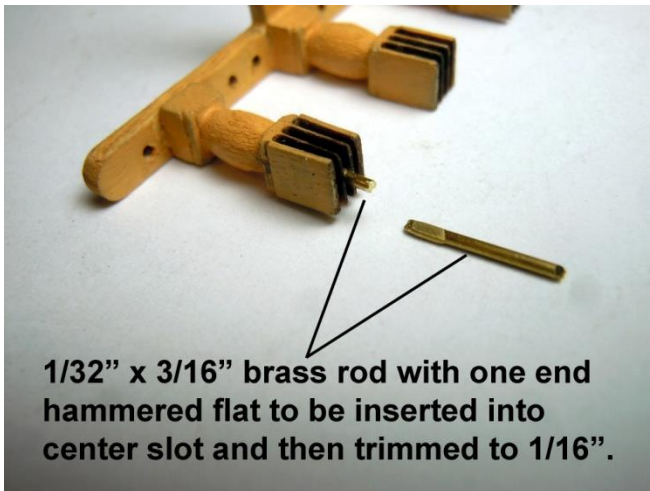

1/32" x 3/16" brass rod with one end hammered flat to be inserted into center slot and then trimmed to 1/16".



Fife Rail in place.

Boarding steps: Remove the four (4) laser cut **Spar Deck Boarding Steps** and the four (4) **Boarding Step Risers**. Remove edge char and assemble as seen in the picture on the next page. Note that the wider **Step** is the top **Step** and positioned flush to the back edge of the **Risers**. Once assembled paint **Dark Green MS4801** all surfaces. Once paint is dry glue in place flush to the edge of the **Hull** and against the **Waterway** resting evenly on the deck. Note that later on in the build a 1/16" **Step Plate** will butt up against the outer exposed edge of the top **Step**.

Note: Due to the delicate nature of the stern hatchway Canopy Frame it will be built towards the end of the build so as not to damage it during the rest of the build.

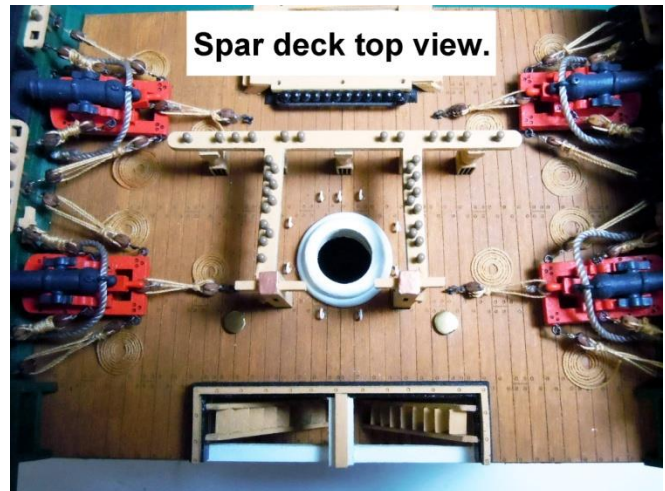

HULL EXTERIOR:

Hull Exterior Walls: Remove the four (4) **Gun Ports** from the two (2) **Spar and Gun Deck Exterior Walls** and set the **Gun Ports** aside for now. Mask off the gun stripe above and below the gun ports and paint **White MS4831**. Once White is completely dry mask off the gun stripe and paint the walls **Hull Spar Black MS4830** as seen in the picture below.

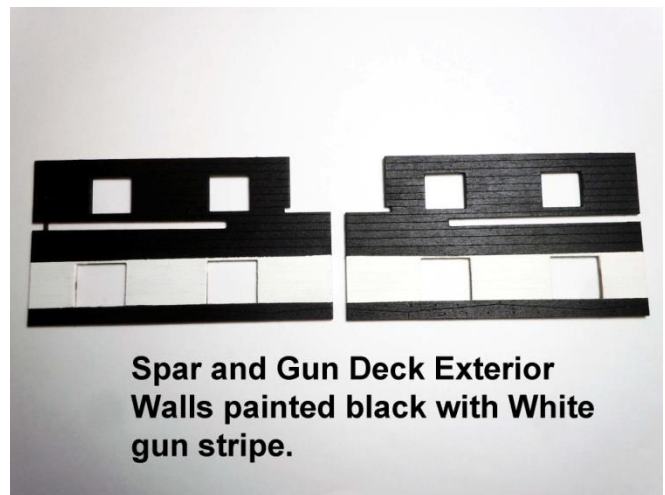
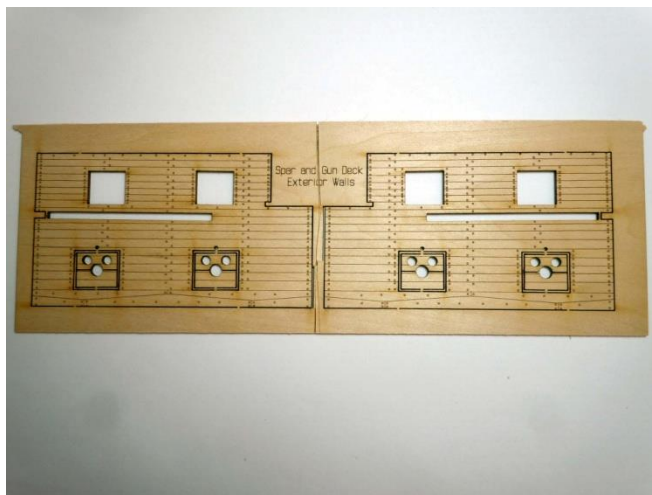

Next add bracing around the **Spar Deck** carronade ports using 1/16" x 1/8" strips, cut and fit as seen in the picture on the next page. Take time to make sure that they are flush with edges, especially the carronade gun ports because these will be critical when adding the **Exterior Walls**. These braces will act as gluing surfaces for the **Exterior Walls**. Add the laser cut **Gun Port Frame Side Braces** and **Bottom Braces** around the gun ports, again taking care that they are flush with the edges and that the **Bottoms** are parallel to ground as seen in the picture on the next page. Note the B; M; M; S sequence with B being the bow.

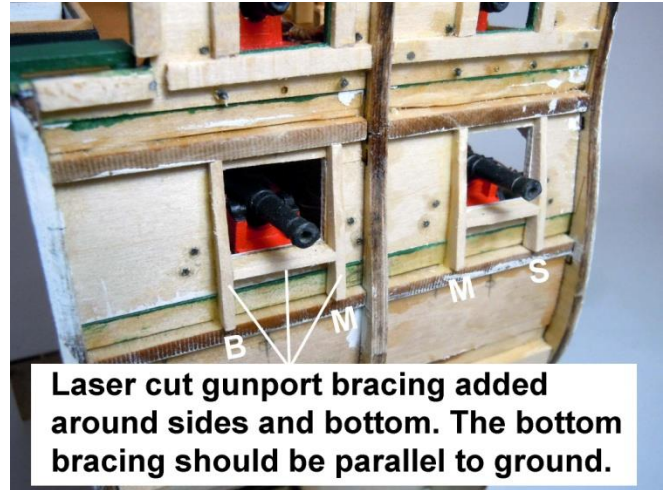

Test fit the painted **Spar and Gun Deck Exterior Walls** one side at a time making sure the gun port openings all index with each other flush to edges and clamp in place making sure clamps do not damage any **Fittings** already in place. Apply Yellow Glue on all the contact surfaces then fit the **Wall** in place and clamp until glue is set. Repeat for the other side again making sure the gun port openings all index with each other flush to edges. See picture on the next page.

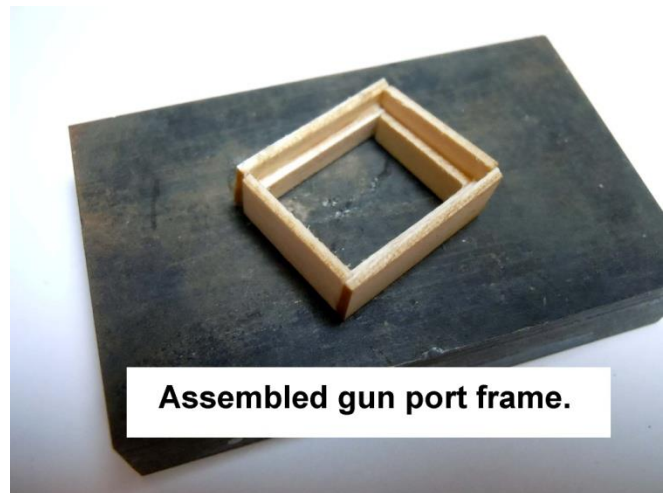
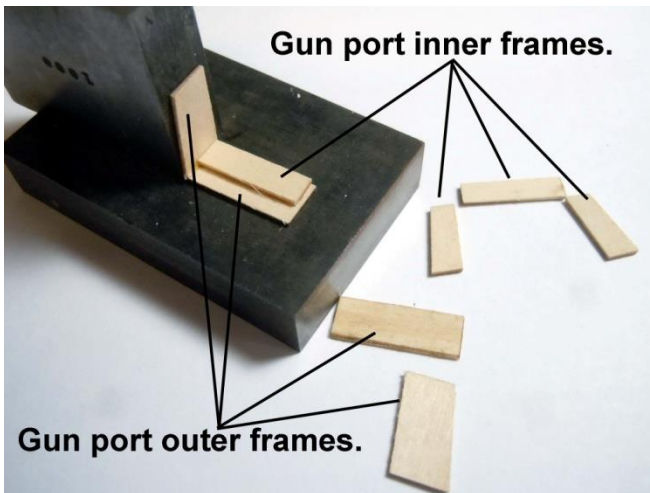

Gun Port Frames: Gather and sand square all edges of the **Inner and Outer Gun Port Frames** to remove the laser char. If steel blocks are available otherwise use what is on hand to build the frames as square as possible. Glue the **Side** edge on top of the bottom edge at 90 degrees. Next glue the **Inner Bottom Frame** part to the **Outer Bottom** and **Side** parts. Let glue set while building the other three in sequence. Next test fit the other **Side** part butting to the end of the **Inner Bottom**. Check for outside surface being flush to the end of the **Outer Bottom** part and if not trim the end of the **Inner Bottom** only to fit. Glue **Outer Side** in place and then glue the **Inner Side** to the inside of the **Outer Side** and check for 90 degree angle. Again set aside to allow glue to set and repeat for the next three. Test fit the **Inner Top** to be flush with the top edges of the assembled parts and adjust if necessary and glue in place. Finally glue the **Outer Top** in place on the **Inner Top** and let glue set. Once all are assembled and glue set sand both front and rear surfaces to be flat and even as seen in the picture above.

Insert the assembled **Gun Port Frames** into the gun port openings and adjust or cut away for press fits. The side fits need to be tight gaps but the tops and bottoms will be covered with the **Gun Port Lids**. This is when the brace surfaces may need some trimming or the top on the inner side wall. Take care when working around the **Gun Barrels** so as not to break them loose. Any gaps can be filled and sanded using thin wood slices glued in place. Once all are test fitted, paint the inner surfaces and inner edges **Black** then glued in place. Paint the **Frames** edges white to match the gun stripe as seen the in picture below. Paint the area below the **Wall** where the **Wales** will go so as not to see wood color in the **Portholes** when they are added later.

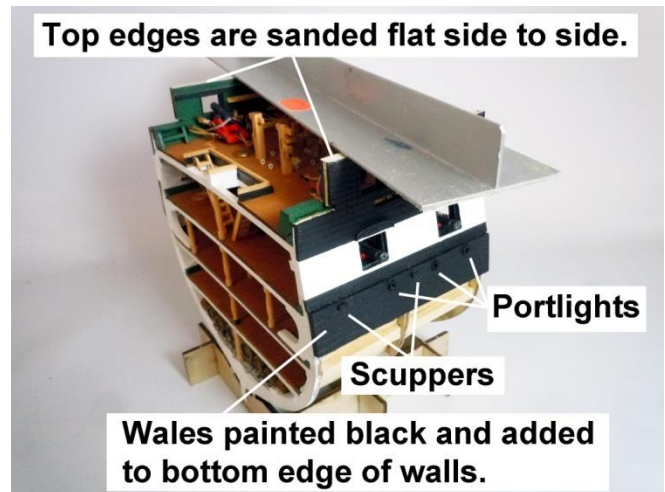
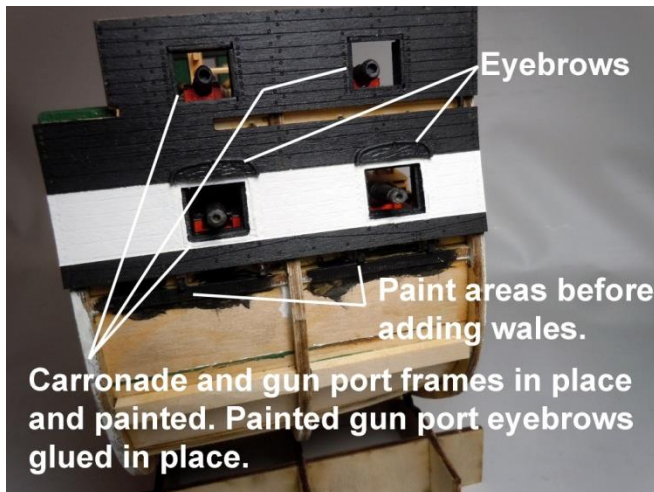

Wales: Remove the two (2) laser cut **Wales** and sand the edges to remove char. Locate the four (4) **Scuppers** and six (6) **Portlights** cast metal parts and trim and clean as necessary then glue them in place into their respective hole locations as seen in the picture above. Note the raised lid on the **Portlights** are up and the raised lines on the **Scuppers** face the bow. Now paint the **Wales Hull Spar Black** and when paint has dried completely glue in place with the **Scupper** forward to the bow. Once both **Wales** are in place and glue set; sand the top edges of the **Side Walls** using a flat sanding device so that inner and outer walls match and are even side to side. See picture above.

Hull Planking – Planking hulls can be challenging on full length hulls, however on this cross section it will be easier but the same principles apply. This hull section will be mostly covered with **Copper Plating** and keep in mind that a smooth hull is very critical, so time and patience is necessary. All **Planks** that will be used are 1/16" x 3/16" x 4-1/4" with the only exception being the last two **Closing Planks**. The key to tight fitting **Planks** is the chamfering of the adjoining **Plank** edge by lightly sanding an angle from the top edge to the bottom edge and slightly removing the bottom edge with a flat sanding device. Use Yellow Glue for its sand ability, CA (super glue) can harden the wood resulting in uneven sanding of the **Hull** surface.

Start planking by cutting the **Full Width Planks** 1/16" x 3/16" x 4-1/4" from strip wood; thirty four (34) will eventually be needed to plank both sides of the **Hull**. Start by edge gluing the first two planks to the **Wales** on either side of the **Hull** and it will be best to work back and forth since this will allow time for the glue to tack off to each edge and **Frames**. Sand each adjoining edge with a slight chamfer for a tight fit and test fit. Apply glue to the edge and set in place and allow to tack off. Once the glue has set on one plank trim the overhanging ends flush to the edge of the **Hull**. This is easier to do one at a time

being able to see the **Hull** edge to cut to using a slicing action with the sharp hobby knife blade. Apply fifteen (15) **Planks** to each side up from the **Wales** and allow the glue to completely set. See picture below.

Now it is time to remove the **Building Fixture** from the **Hull**. First remove the two (2) **Fixture Legs** and then with a **Hobby Knife Saw Blade** saw the joints at the **Hull** and remove the three (3) **Frame Legs** one at a time. Sand the joint areas smooth with the **Hull** as seen in pictures below.

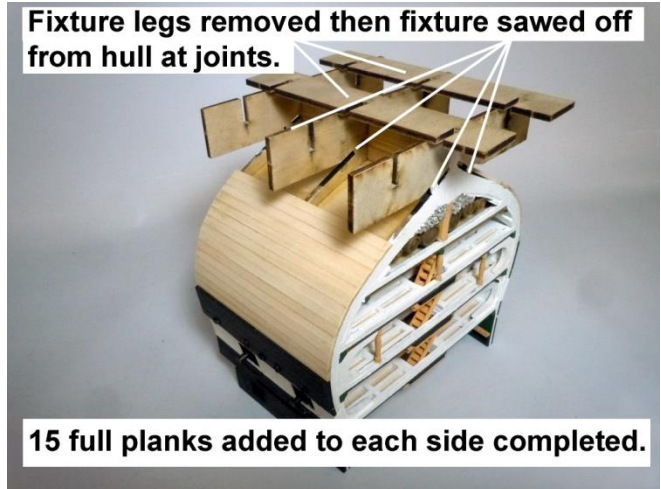
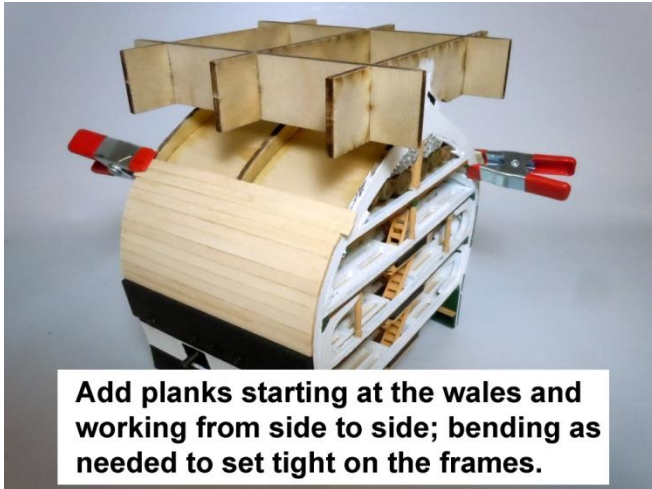

Next add two (2) **Full Width Planks** down against the **Keel** as seen below. The rest of the **Planks** will now have to be tapered lengthwise taking off 1/32" at the **Stern** end while the **Bow** end stays full width. Add one (1) **Plank** adjacent to the two (2) **Planks** against the **Keel** and four (4) up from the **Wales** side as seen below. These **Planks** will require slight bending to conform to the **Hull** curvature.

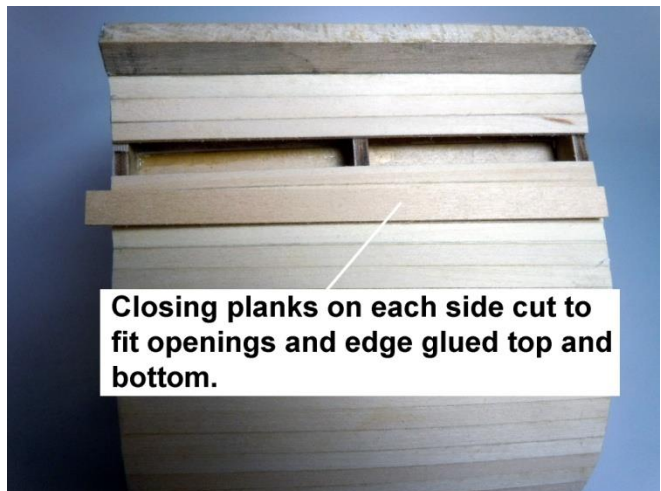
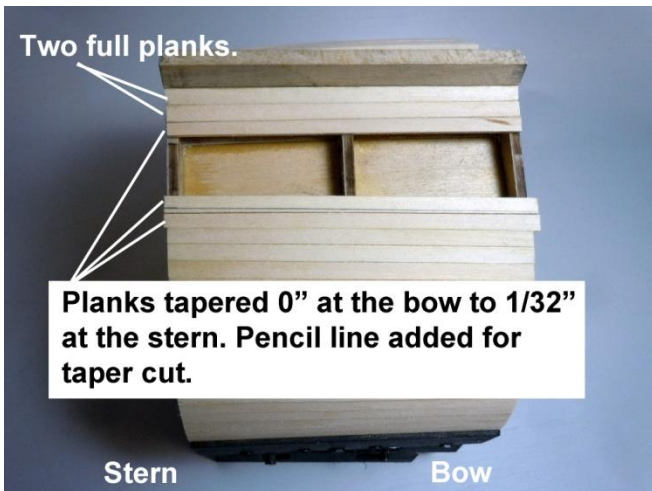

Now the resulting opening will be wider than the **Full Plank** but if the **Plank** were added would result in a very slim **Plank**. Now cut the **Closing Plank** using 1/16" x 7/16" x 4-1/4" to fit as tight as possible into the opening. Once satisfied with the fit, glue the **Closing Plank** in place with glue applied to top and bottom edges and **Frame** surfaces. Allow the planking glue to set completely, overnight would be best. After the glue has set slowly and carefully sand the entire planked surfaces to a very smooth finish. Rather than sand lengthwise on the **Planks**, better results can be achieved when sanded diagonally fore and aft developing the curvature of the **Hull**. Next apply **Wood Conditioner MS4973** to the entire

sanded **Hull** surfaces. Check for smoothness and if necessary sand smooth. A smooth surface is **critical** for the application of the **Copper Plating**. Paint **Black** up about one (1) inch up from the **Wales** on each side avoiding a hard painted edge. Very lightly sand the painted edge to blend with the wood surface as seen in the picture below. Wipe clean any residual dust from the sides of the **Hull**.

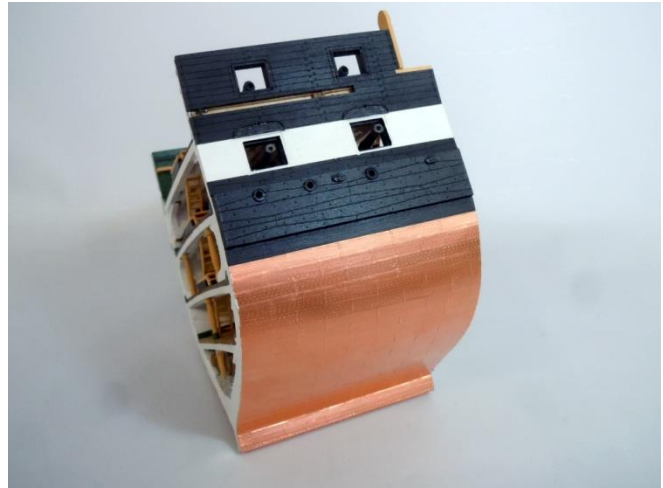
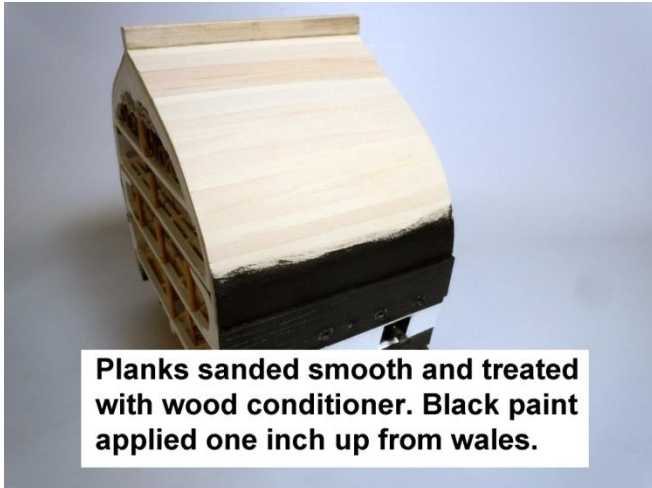

Hull Copper Plating: The photo above shows the reason why the smooth hull is required and necessary. The **1/4" Copper Foil Tape** is extremely thin and will telegraph any imperfection below it. If this is your first time applying **Copper Foil Tape**, read through this section and study the pictures to better understand the complete process. It is easier to remove the copper tape from the carrier paper by brushing the end of the plate without the small marks with your finger tip to separate and then seize the lifted edge with tweezers.

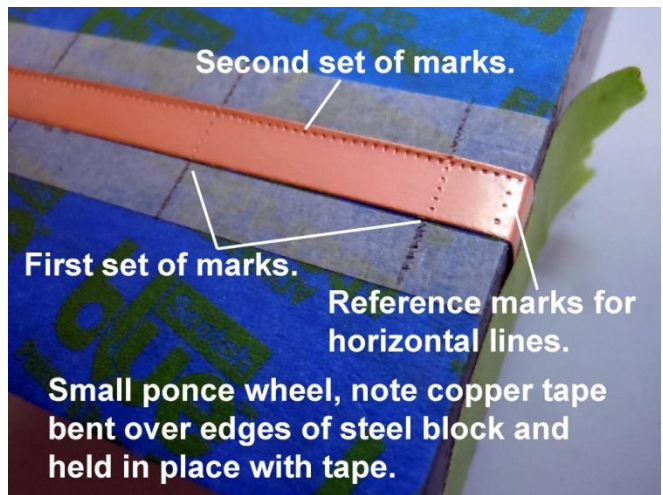
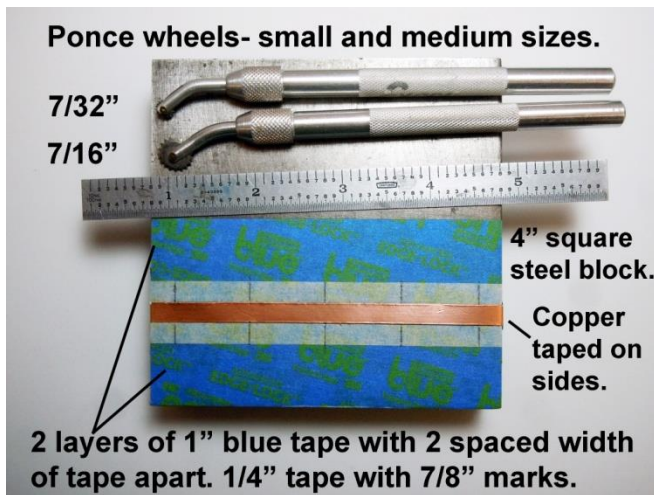

Best coppering results require the use of a smooth steel surface like the 4" square steel block available at retail hobby outlets; as well as, two sizes of ponce wheels – small (7/32") and medium (7/16"). Also needed are a 6" steel rule; 1/8"; 1/4"; 3/4" and 1" masking tape sizes. Sharp scissors and a scribe will be used as well. To start building the plating fixture apply two (2) layers of the 1" tape flush with the edge of the steel block. Position the copper foil tape as a spacer and apply two (2) layers of 1" tape flush to the top edge of the copper foil tape. Next apply a layer of 1/4" tape along the edges of the 1" tape as seen on the previous page. Now mark the center line using a pencil and small square on the

1/4" tapes and then additional marks 7/8" apart in five (5) lines defining four (4) plates. Insert a 5" length of **Copper Foil Tape** centered side to side between the masking tape and bend the right end down over the edge of the steel block and tape in place. Bend the left edge and tape in place to the side of the steel block. Using a **Ponce Wheel** is best held with the shaft holding the wheel be perpendicular to the **Copper Foil Tape** with a gentle pressure **downward** rather than forward and move the wheel slowly and evenly against the edge of the **Steel Rule**. With the **small** ponce wheel and using the 6" steel rule aligned on the pencil lines roll the wheel against the edge of the steel rule as seen in the picture on the previous page. Next align the steel rule 1/32" along the top edge of the **Copper Foil Tape** and mark the top edge with the small ponce wheel. Use the point of a scribe to mark three equidistant reference marks for the horizontal line of marks to be added using the **Medium** size **Ponce Wheel** as seen on the previous page. Carefully align the steel rule using the top reference mark and parallel to the top small wheel marks and use the **Medium** size **Ponce Wheel** against the edge of the rule slowly and carefully mark the row. Repeat for the next two marks as seen in the picture below.

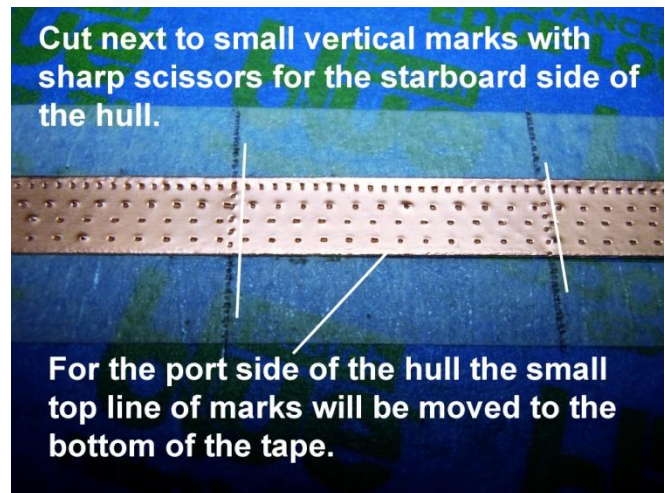
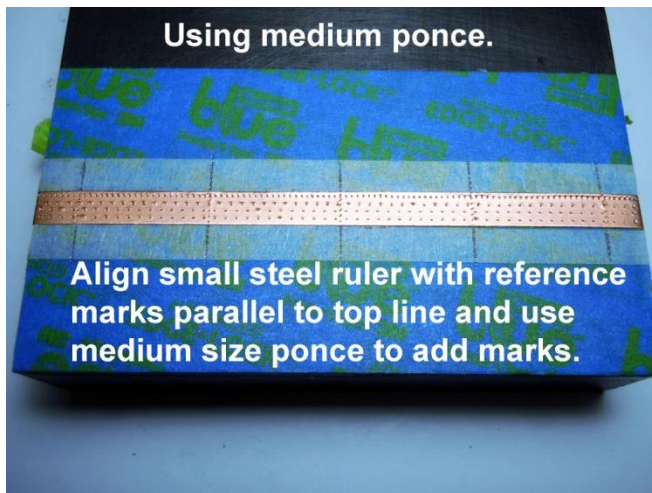

Remove the marked strip of **Copper Foil Tape** from the retaining tape on the sides of the block. With sharp scissors carefully cut 1/32" parallel and to the right of the small vertical marks to cut the individual **Plates**. This set up of marks is for the **starboard** side of the **Hull**. The **port** side will require moving the lengthwise line of small marks be moved to the bottom edge of the **Copper Foil Tape**. Cut as many strips into **Plates** as you feel comfortable doing; one **Hull** side will require 18 rows with 5 Plates per row plus three **Belting** rows for a total of 105 **Plates** per side.

Start applying **Plates** by starting at the stern end of the **Keel** and apply the side **Plates** first and overlapping by 1/32" each **Plate** as they are applied to the bow end of the **Keel**. As each **Plate** is placed in its final position, burnish it flat with the back of a fingernail in a direction towards the stern and over the overlapping joint. Second, start at the stern and apply the first half **Plate** with the top line of small marks slightly overlapping the **Keel** side **Plates** and the small end marks to the stern. Continue down the row with full size **Plates** as seen in the picture on the next page. Trim the end **Plate** as necessary. Keep in mind that the **Plates** will alternate like bricks with joints being halfway on a **Plate**. Start the second row at the stern with a full **Plate** again with the end small marks to the stern. When positioning **Plates** try to align the lines of marks to visually looking like a continuous line; and tweezers will help with the handling of the **Plates** to position and place them. Once a couple of rows are in place

go back to the **Keel** and apply a row of **Plates #3** halfway down the side and bent over the top. Save #4 until both sides of the **Hull** are completed.

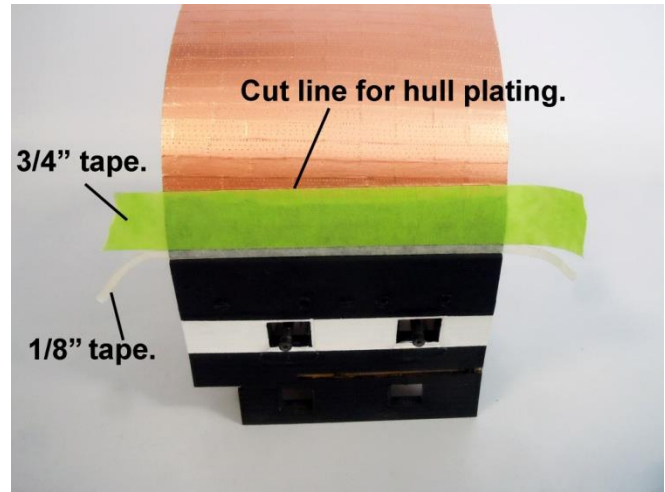
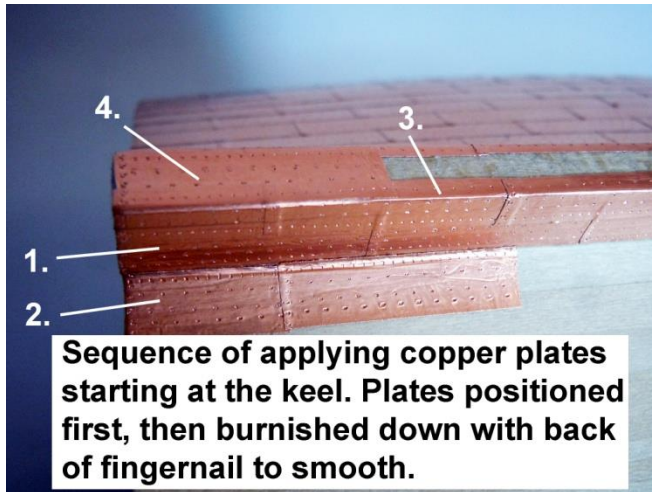

Now continue with the rows of **Plates** on then starboard **Hull** and stop at fifteen (15) rows. Repeat the plating process now on the port side of the **Hull**. Keep in mind to change the top row of small marks now to the bottom edge of the **Copper Foil Tape**. A self check is that the small marks line is towards the **Keel** and the end small marks are to the stern when correctly applied. Once both sides of the **Hull** and **Keel** sides have been covered apply the top surface of the **Keel #4** and **important** both edges will have a line of small marks.

Belting: The top three (3) rows are the **Belting** (dressing) rows of the **Copper Plates** and they run parallel to the **Wales** while the **Hull Plates** will angle into them due to the **Hull** curvature up from the **Keel**. To establish the cut line of the **Copper Foil Plates** lay a strip of 1/8" tape along the edge of the **Wales** and then a strip of 3/4" tape flush to the 1/8" tape. The top edge of the 3/4" tape is now the cut line to follow with a sharp hobby blade. See the picture above. Carefully cut along the top edge of the tape through the **Copper Foil Plates** then remove the tape. Next with the tip of the blade under the edges of the **Copper Plates** remove the excess unwanted foil. Now apply a strip of 1/4" tape along the edge of the **Wales** and this will define the top edge of the **Belting** rows. Then apply a 1/8" strip of tape 1/32" below the cut edge of the **Hull** plating providing an edge to align the bottom edge of the first row of **Belting Plates**. See the picture on the next page as well as **Plan Sheet 2**. Apply the three (3) rows of **Belting Plates**. **Important:** the top row will have the small marks lines on both top and bottom edges. See picture on the next page. Remove the 1/4" tape against the **Wales** and the **Hull** plating is complete. Caution must now be used when handling the **Hull** so as not to lift any edges or corners of the **Foil Plates**.

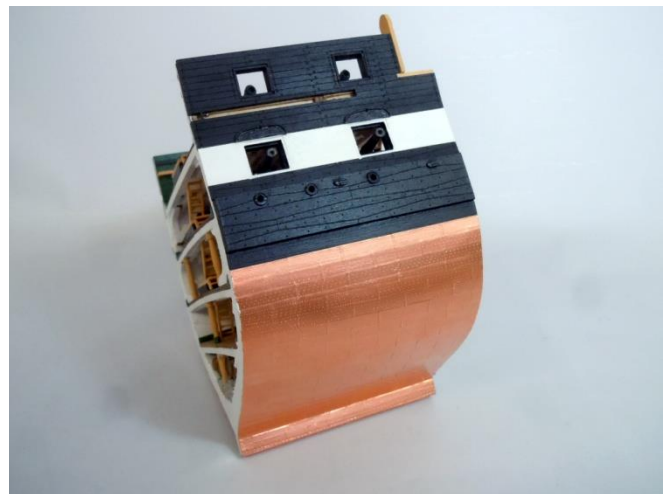

Display Stand

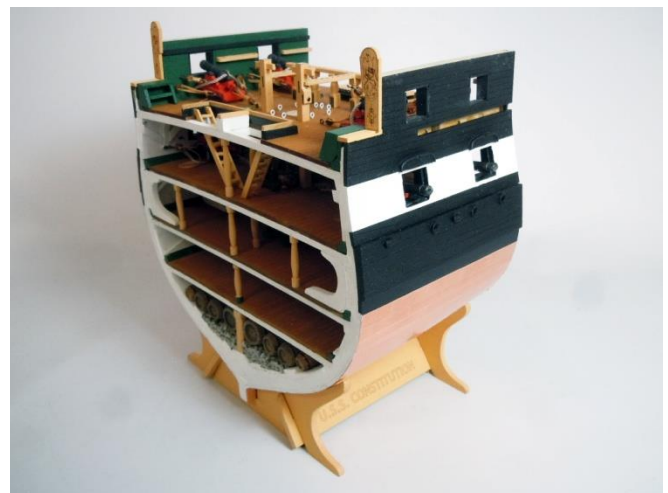
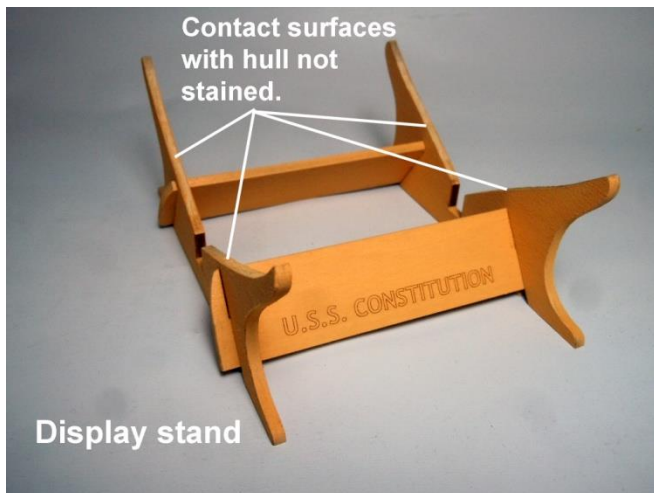

Display Stand: Remove the four (4) **Display Stand** parts from the carrier sheet and sand all edges to remove the laser char. Apply **Natural Stain** to all surfaces except the ones that will come in contact with the **Copper Foil Plates** of the **Hull**. Index the **Cross Braces** into the **End** part slots and glue them from the underside that cannot be seen when in final position. Once glue has firmly set, carefully place the **Hull** into the **Display Stand**. Note that the Bow and Stern **Hull** curves are different and the **Hull** will only fit correctly one way in the **Display Stand**. See pictures on the previous page. **TIP:** Add a rubber band around the bottom of the **Stand** and **Hull** to keep the **Hull** in place while working with it to keep the **Hull** from slipping out of the **Stand**. Note: most glues will not work long term on the **Copper Foil**.

HULL FITTINGS:

Trail Boards: Remove the four (4) laser cut **Gangway Trail Boards** and two (2) **Gangway Step Plates**, file and clean the edges of char and stain using Natural Stain. Glue the **Step Plates** in place butt up against the **Steps** and indexed into the notch in the **Hull**. Glue the **Gangway Trail Boards** against the **Hull** sidewall surfaces with the inboard edges aligned with the inboard edges of the **Step Plates** as seen in the picture below. Next glue the second **Trail Boards** in place on the top surfaces of the **Step Plates** and flush with the ends of the **Step Plates**.

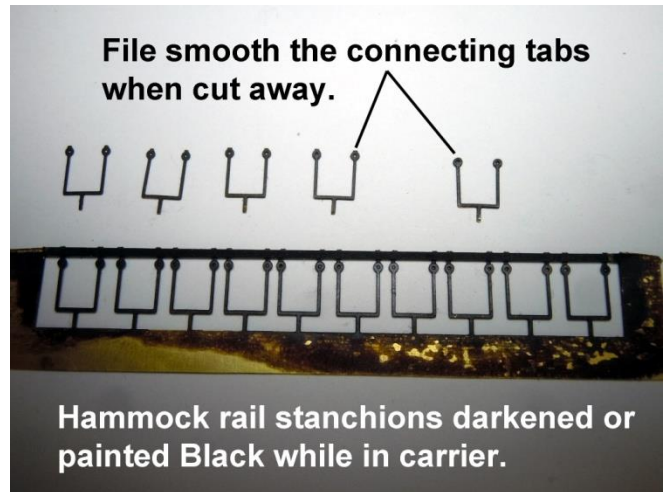

Cap Rails: Darken or paint the photo etched **Hammock Rail Stanchions** and cut free from the brass carrier sheet. Make sure to file smooth the top connecting tabs smooth with no burr as seen in the picture above. Cut two (2) 1/8" x 1/4 x 3-7/16" strips and cut the outer edges with a double half round profile. Molding cutters are available at retail hobby outlets. Next add **Eyebolts** by drilling .020" holes starting at the **Trail Boards** at 3/32" for the first hole; next hole at 1/2" then the next three 3/4" apart with the last 1/16" from the **Stern** end. On the top surface drill 1/32" holes starting at the **Trail Boards** at 1/2" for the first hole; then the next three 3/4" apart with the last 1/16" from the **Stern** end. Glue **Eyebolts** into the side inboard holes for two mirror imaged **Cap Rails**. See picture on the next page. Paint the **Cap Rails Hull Spar Black** taking care not to paint-fill the drilled holes on top. Once paint is dry glue the **Cap Rails** with the **Bow** end against the **Trail Boards** centered on the top of the **Hull** sidewalls. Now glue the **Hammock Rail Stanchions** into the 1/32" holes on top of the **Cap Rails**. See the picture on the next page.

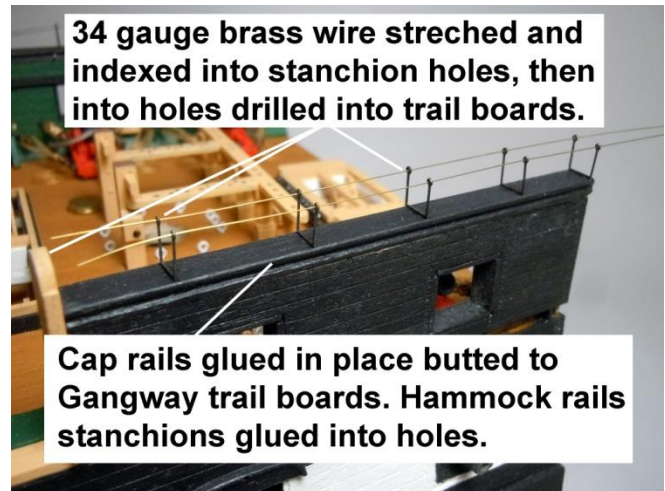
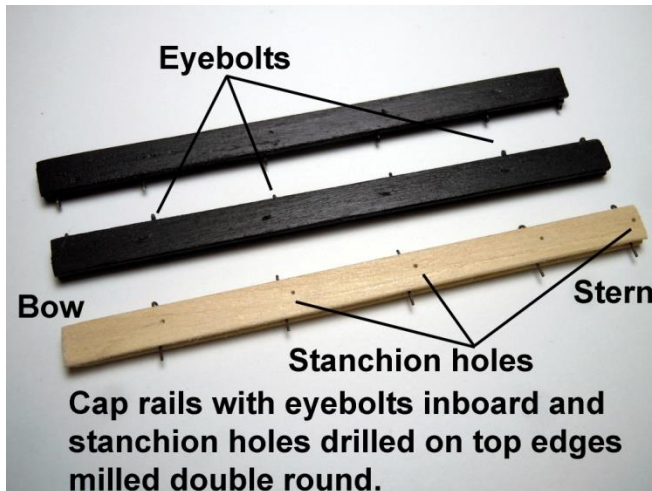

Cut four (4) 6" lengths of 34 gauge **Brass Wire** and gently stretch the wire while each end is held by pliers to stiffen and straighten. Carefully index one end of the wire through the holes on top of one side of the stanchions to the **Trail Board**, then drill a .020" into the **Trail Board** into which the end of the wire will be indexed into and glued in place. Glue the wire using CA at each **Stanchion** hole and at the **Trail Board**. Once the glue has set cut off the excess wire at the end adjacent to the **Stanchion**. Repeat adding the wire to the rest of the three **Stanchion** tops and let the glue completely set.

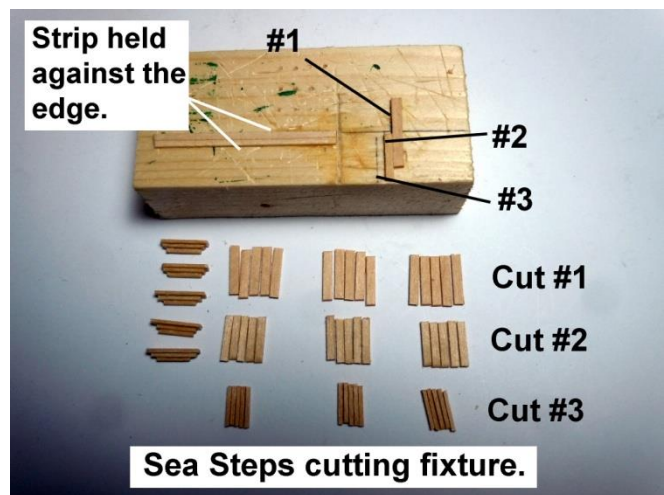

Cut two (2) pieces of **Netting WP2828** 1" x 4" also cut a piece of thin **Plastic Film** 1" x 4" to be used as a barrier for the CA glue. Next fit the **Netting** between the **Stanchions** butted against the **Trail Boards** and then with a 1/8" x 4" wood strip wrap the plastic film and very carefully fit the plastic wrapped wood strip into the **Stanchions** as a spacer and fixture to adjust and final fit the **Netting**. See picture above. Now very carefully apply drops of CA along the top edge of the wire to glue the **Netting** to the **Wire** and allow the glue to set. Check along the top edge for adhesion of the netting to the wire and apply glue as needed. Once glue has completely set carefully remove the wood strip and then remove the **Plastic Film** which may stick due to the glue so gently push/pull the film lengthwise to release. Now with a sharp hobby knife blade slice away the excess netting along the top and end edges of the **Wire** cutting outward against the **Wire** as a cutting guide. Repeat this process for the other **Cap Rail**.

Sea Steps: The **Sea Steps** are fabricated by laminating three (3) pieces of 1/64" strip stock together. First build a **Cutting Fixture** as seen on the previous page as a gauge to cut the 60 pieces that will be needed in three (3) sizes. Using 1/64" x 3/32" wood strip stock cut twenty (20) pieces 1/2" long, the width between the **Trail Boards**. Using 1/64" x 1/16" wood strip stock cut twenty (20) pieces 7/16" long and then using 1/64" x 1/32" cut twenty (20) pieces 3/8" long. Since the pieces are small it is easier to work with them stuck to masking tape to hold them in place while building the **Sea Steps**. **Step 1:** Place the 1/2" long parts equally placed on masking tape as seen in the picture below. **Step 2:** Then using Yellow Glue applied to one side of the 7/16" parts glue them with one edge aligned with the top edge and centered lengthwise on the 1/2" parts. **Step 3:** Apply glue to the 3/8" parts with one edge aligned with the top edge and centered lengthwise on the 7/16" parts. Once glue has set prime the parts and sand smooth and then sand/file the ends quarter rounded as seen in the picture below. Then paint the **Sea Steps** White

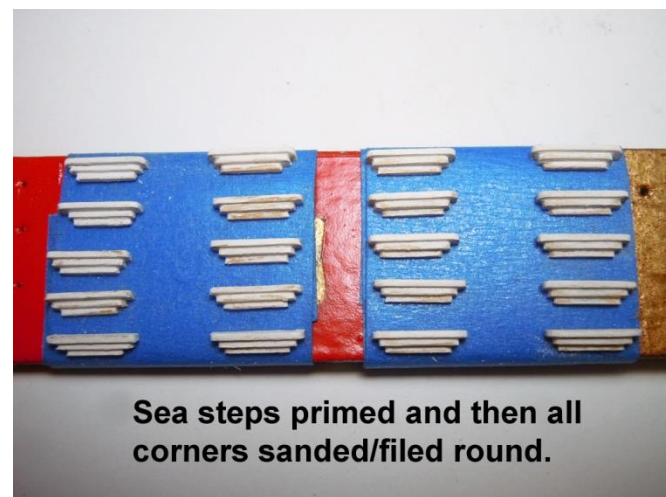
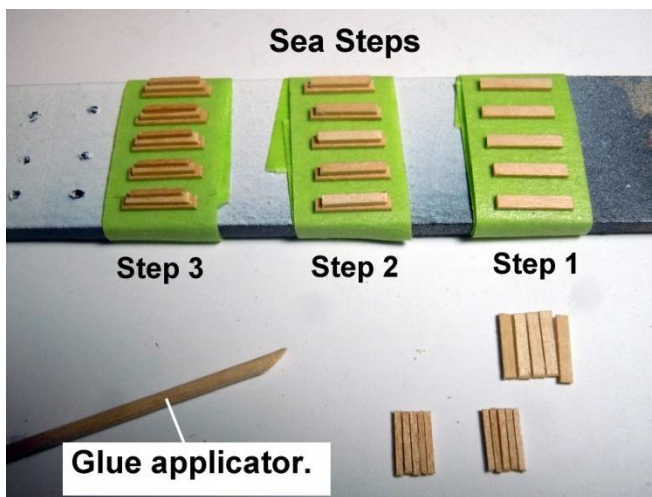

Take four (4) of the painted **Steps** and glue one with the top edge aligned with the top surface/edge of the **Wales** and the outer edge of the **Hull**. The inboard end should be tight to the **Scupper**. Add the second **Step** with its bottom edge aligned with the bottom surface/edge of the **Wales** and the outer edge of the **Hull**. Then using 3/32" spacers (cut from scrap) add the additional two (2) **Steps** between those in position already. Now add a strip of 1/4" masking tape vertically aligned with the inner edge of the **Trail Board**. Now glue the remaining six (6) **Steps** in place using spacers starting at the top of the **Wales** and aligned against the tape edge. Note that there is an offset due to the location of the **Scuppers**. See the picture on the next page and Plan Sheet 2. Carefully remove the tape once the glue has set a little.

Trim Molding: Cut three (3) 1/16" x 3/32" x 5" wood strips and cut to a double half round profile to be fitted across the top of carronade openings butted up against the **Trail Boards**. Then cut two (2) 3/4" long pieces and glue them below the **Trail Boards** and flush with the end of the **Hull**. See picture on the next page.

Hand Rails: Locate and drill twelve (12) .020" holes for six (6) **Hand Rail Eyebolts** port and starboard; two (2) in the edge of the **Trail Boards** aligned with the end of the **Trim Molding**; two (2) into the edge of the **Step Plate** at the bottom of the **Trail Boards** and tangent to the top of the **Trim Molding**; the

final two (2) between the **Wales** top surface and the bottom edge of the **Sea Step** aligned vertically with

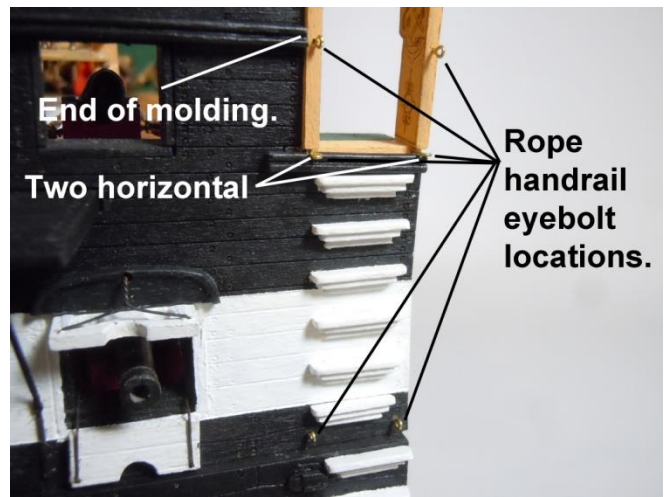
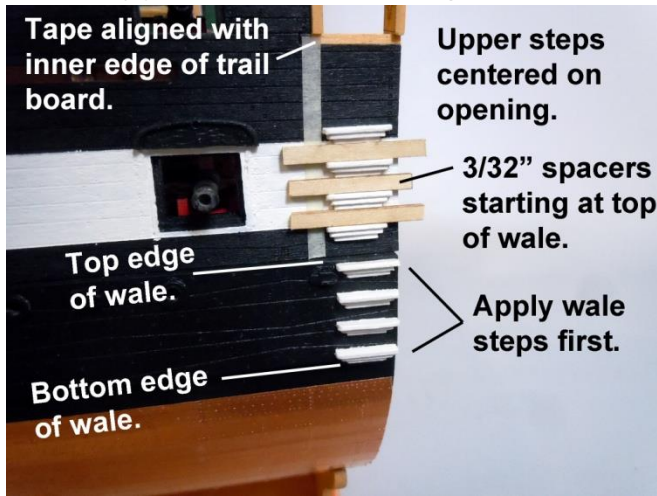

the previous **Eyebolts**. See picture above, **Eyebolts** are brass for clarity to see. Glue the darkened or painted **Black** eyebolts, **Jackstays MS0429** in place with the top and bottom eyebolts oriented vertically with the middle ones oriented horizontally.

Now using a length of **(1210)** black rope seize one end to the lowest eyebolt; then feed through the middle horizontal eyebolt and then seize to the top eyebolt. Add a drop of glue mix to the knots, let dry and trim off excess. See picture on the next page.

Gun Port Lids: Remove and clean the laser char from four (4) **Upper Lids** and four (4) **Lower Lids**. Remove eight (8) **Hinges** for the **Upper Lids** from the photoetched sheet and file smooth the connecting tabs. Glue the **Hinges** to the **Upper Lids** outboard of the window holes and flush to the top edge. Then drill .020" holes in the lower corners as seen in the picture on the next page. Paint the **Lids** White all surfaces. To simulate the **Lid** ropes use four (4) darkened/painted pieces of the 34 gauge brass wire and form an eyebolt with a twisted end (#1); then form the legs to index into the holes on the **Upper Lids** (#2); now cut the twisted end 5/16" long from the intersection of the legs (#3); test fit the **Lid** in place so that the **Lid** is parallel to ground with the twisted leg inserted into the hole above the gun port. Trim leg if necessary. Now glue the **Lids** in place against the top frame of the gun port. For the lower ropes form a 90 degree bend to insert into the holes and then form a second bend the height

of the **Lids** and cut the length to 5/8" and glue into the holes and onto the **Lids** with the wire parallel to the edges of the **Lids**. Test fit the **Lids** and trim wire legs if necessary; then glue the **Lids** in place with the top edges flush with the top edges of the gun port frames See picture below.

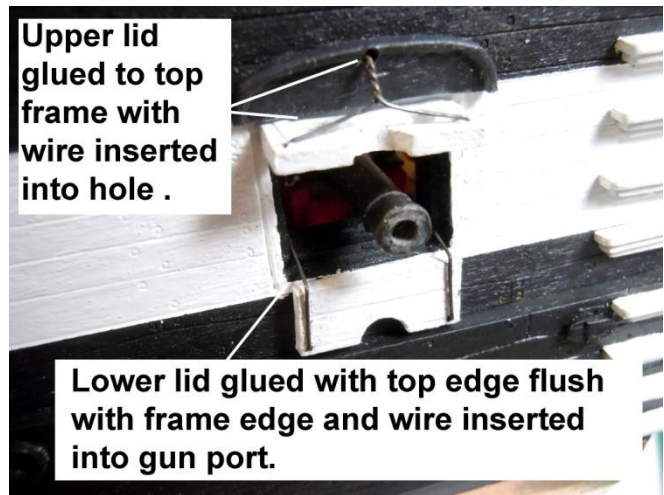
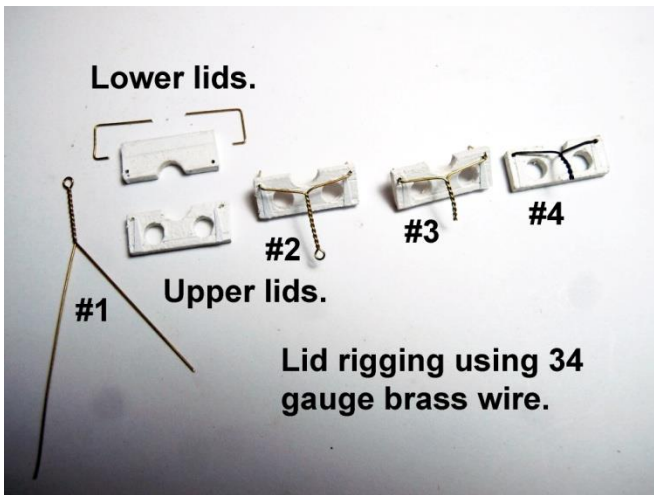
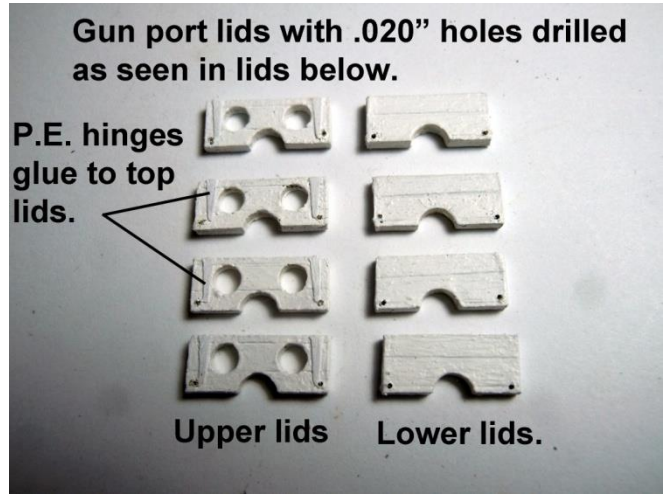
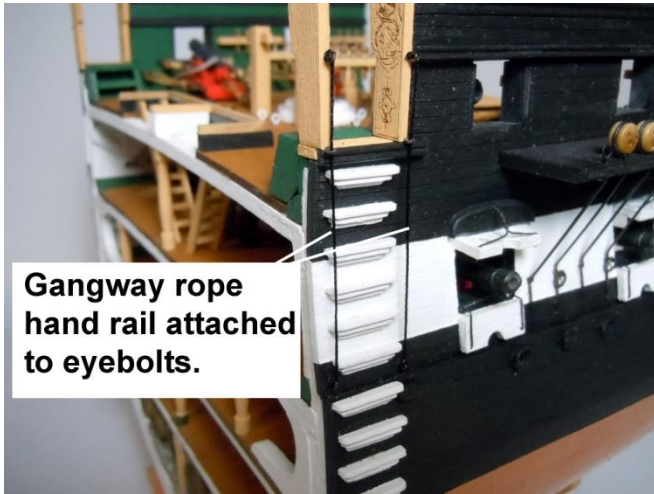

Channels: Remove and clean edges of laser char for the two (2) **Channel** parts. Using 1/16" x 3/32" x 6" wood strip cut the molding profile using a cutter. Cut two (2) lengths of molding the length of the channel edges with the notches. Form two (2) **Eyebolts** using the Black 28 gauge wire with a 1/2" long twisted legs. Now using a drift punch on a steel block, flatten the twisted leg to within 3/32" of the open eye so that when bent 90 degrees the eye will be flush with the top surface of the **Channel** when the flattened leg is glued to the underside of the **Channel**. Paint the **Channels** and **Moldings** Black

Now using ten (10) 3/16" **Deadeyes** MS0340 strop (wrap and twist) the **Deadeyes** with a 1/2" twisted leg and flatten like the **Eyebolts** so that the bottoms of the **Deadeyes** are flush with the top surface of the **Channels** when bent. See the picture on the next page. Index the **Eyebolts** and **Deadeyes** tight into the back of the notches in the **Channels** and glue to the underside of the **Channels**. These parts will be under a great deal of stress when adding the **Shrouds** so make sure they are glued securely.

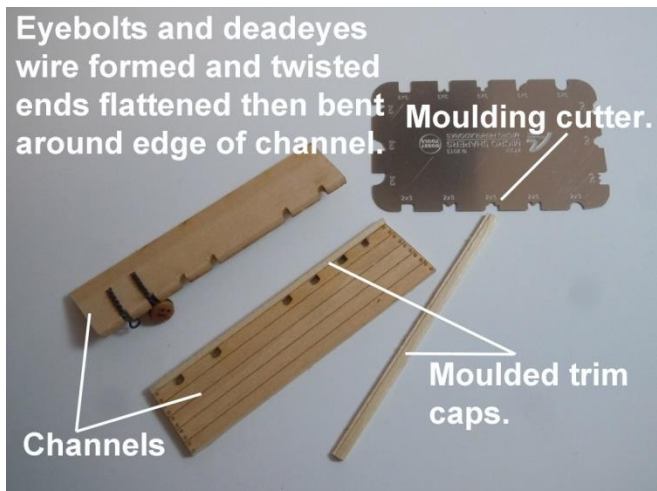

Once both paint and glue has set, carefully glue the **Molded Trim Caps** in place and avoid putting glue into the notches, space is needed to insert the **Chain Plates** later. Or, based upon skill level the **Moldings** can be added later once the **Chain Plates** have been added. Check for the small web that held the **Sidewalls** aligned and if still in place remove it from the aft end of the slot. Now glue the **Channels** in place in the slots in the **Hull** with the **Eyebolt** ends towards the **Bow** and parallel to ground. See picture above.

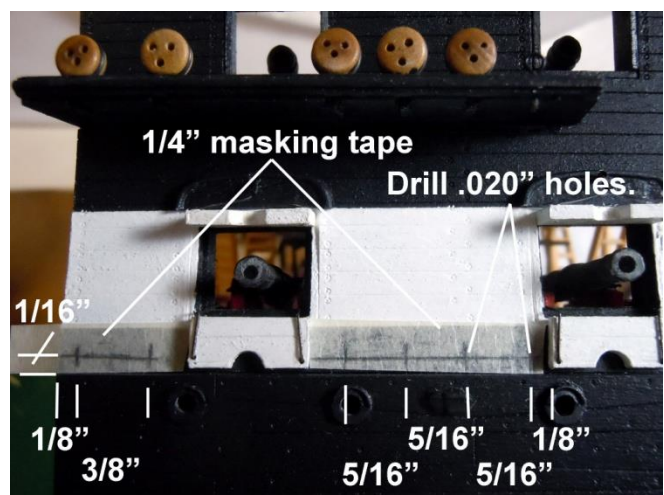
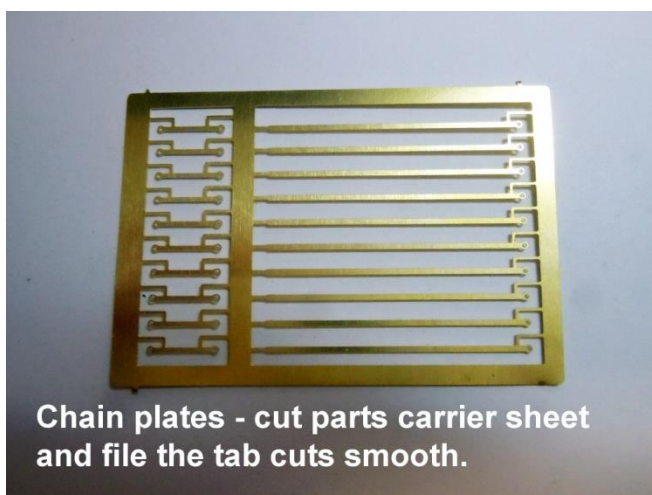

Chain Plates: The **Chain Plates** consist of two (2) parts; a short **Link** and a long **Strap**. Remove the parts from the carrier sheet and carefully file smooth the connecting tab cuts. Darken or paint **Hull Spar Black** all the parts. Apply 1/4" masking tape along the top edge of the **Wales** on either side of the aft gun port. Mark a horizontal line 1/16" above the **Wales**. Now mark hole locations 1/8" from the stern edge of the **Hull** and the forward gun port **Lid**. Then from the aft mark add another mark at 3/8". From the forward mark add three (3) marks 5/16" apart. Drill .020: holes at each mark. Repeat steps for the other **Hull** side. Using a **Jackstay** inserted through the bottom hole of the **Link** into a hole align the **Link** with **Channel Eyebolt** or **Deadeye** and mark the top hole of the **Link** and drill a .020" hole. Glue the **Link** in place on the **Hull** making sure the holes align. Bend the end of the **Strap** with the hole in it to conform to the top hole in the **Link** and the edge of the **Channel**. Use a **Jackstay** to help hold in place and mark the **Strap** at the bottom edge of the **Channel** and then bend parallel to the edge of the **Channel**. Cut the **Strap** 3/32" above the bend. Remove the **Jackstay** and insert the bent end into the

notch opening at the **Eyebolt** or **Deadeye** reinsert the **Jackstay** and glue the bent end in place in the notch in the **Channel**. When the glue has set remove the **Jackstay** and glue the bent end of the **Strap** to the top of the **Link**. See the picture below. Repeat the steps for all **Eyebolts** and **Deadeyes** in the **Channels**. With six (6) **Jackstays** and six (6) 1/8" **Split Rings MS0955** add the **Rings** to the **Jackstays** then darken or paint Black. Insert trimmed **Jackstays** into the top holes in the **Links** as seen in the picture below.

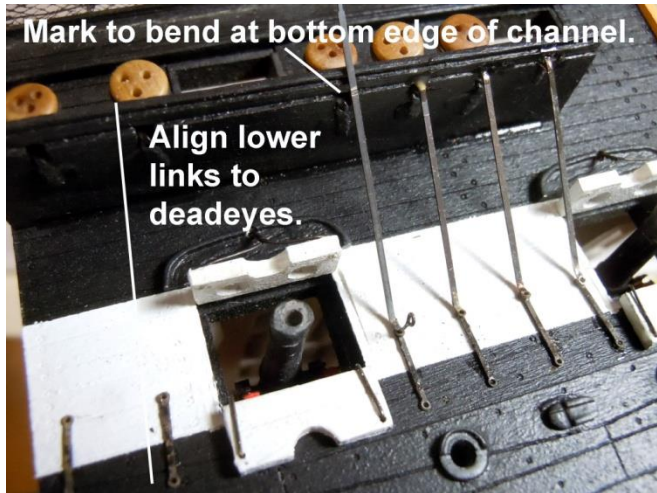

The basic **Hull** is now complete and should look like the bow view below.

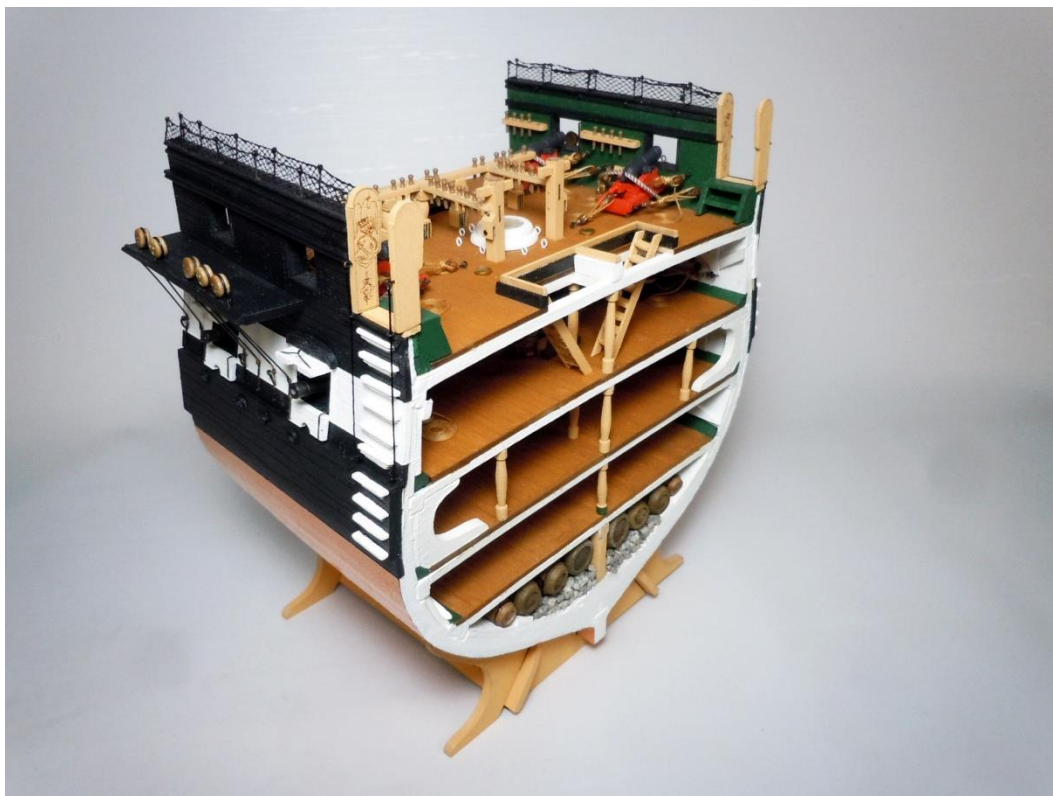

BUILDING THE MAIN MAST:

The **Main Mast** is comprised of three sections: **Lower Mast**, **Topmast** and **Topgallant**. Build in the following sequence and care must be taken when building the **Fighting top** for follow on assembly. **IMPORTANT:** Pay attention to adding the **Mast Caps** and **not gluing** them in place until final assembly of the complete **Mast**.

Lower Mast - Select the $7/16$ " dowel and cut to the length of $16-3/8$ " long. Mark the spar deck line around the **Mast** at $4-7/16$ ". Taper the dowel from this line down to the bottom to $3/8$ " diameter. Tapering based upon the type of dowel can be done by sanding block with 80 grit sand paper then smoothed with finer grit. Next mark two lines up from the bottom at $1/8$ " and $3/16$ ". Cut the bottom to $7/32$ " diameter using a sharp hobby knife at the $1/8$ " mark. Now at the $3/16$ " line cut an angle to the $7/32$ " round diameter. This end will set into the **Mast Foot**. See the photo below.

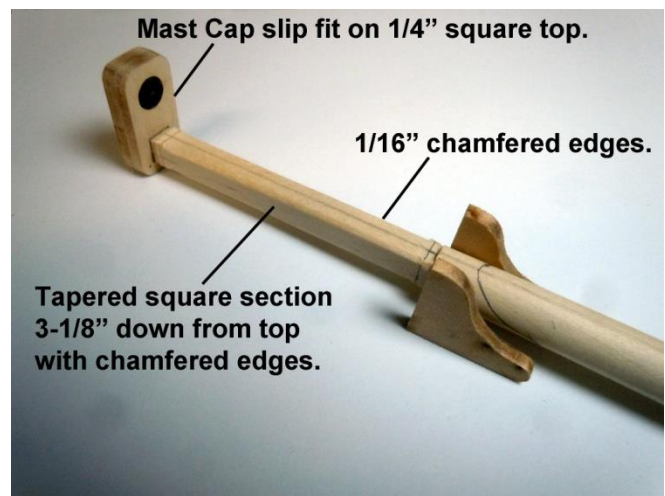
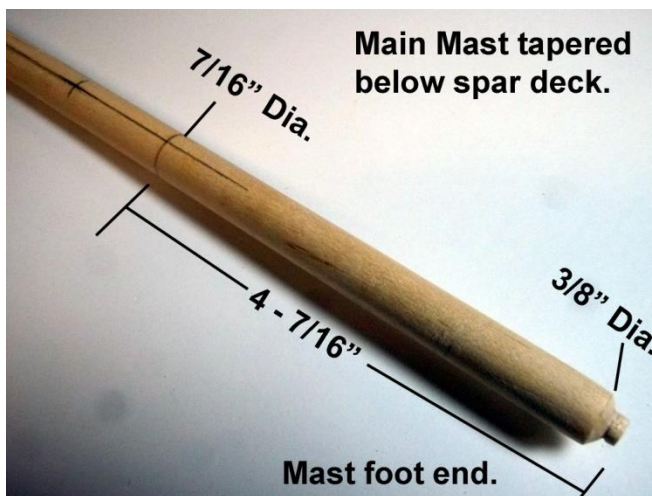

Taper the dowel from the **Spar Deck** line to the top (12") with the top diameter being $3/8$ ". Long tapering can be done with 80 grit sanding block, use of a small plane or turned on a lathe if one owns a lathe. Work slowly and evenly for a smooth taper. Sand smooth to remove any cut marks. Once satisfied with finished taper add a mark down from the top at $3-1/8$ " around the **Mast**. Score the line with a sharp hobby knife so as to cut from the line to the top a tapered square upper section. Sand/file the tapered square sides flat and smooth. Next mark at $1/4$ " down from the **Mast** top and cut a $1/4$ " **Cap Tenon** (square section) which the **Mast Cap** will press fit on and be flush with the top surface of the **Mast** as seen in the photo above. From the square section cut lines, top and bottom at $1/8$ " cut/file a $1/16$ " chamfer on the four (4) edges of the square section.

Chafing Fish: Using $1/16$ " x $1/8$ " Basswood strips; six (6) at $4-5/16$ " long and three (3) at $8-7/8$ " to be applied to the **Mast** starting at the square section and down the **Mast**. Mark a reference centerline down the length of the **Mast** and glue the center long strip in place first. Then angle cut the adjacent side of the two outboard long strips and glue to **Mast** and center strip. Then glue three (3) shorter strips on either side of the three center strips with angle cut edges for tight fitting joints as seen in picture below. Once the glue has set sand the **Chafing Fish** round and smooth and cut/file round the lower outboard corners of the shorter strips as seen in the picture on the next page.

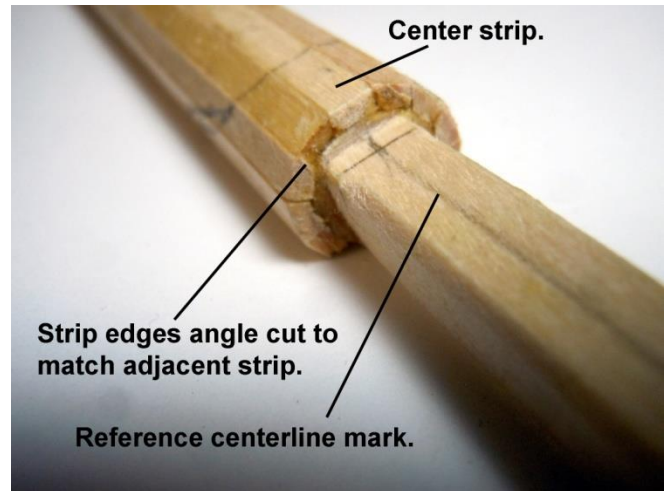
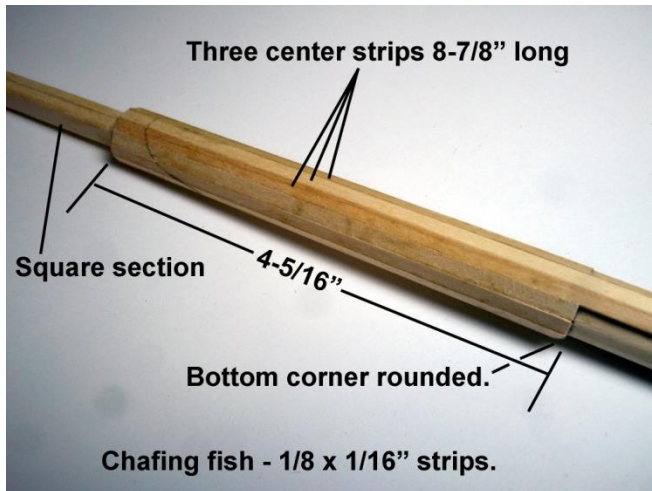

Cheeks: Remove and clean the edges of the two (2) **Lower Mast Cheeks**. Lay the **Mast** on a flat surface facing up and align the top edges of the **Cheeks** with the top edges of the **Chafing Fish** and tangent to the **Mast** as seen in the picture below and mark the outlines on the **Mast** with a pencil. Using the outline carefully cut the recesses to a depth such that the inner surfaces of the **Cheeks** are 3/8" apart and parallel to each other. Once satisfied with fits glue the **Cheeks** in place as seen in the picture on the below making sure they are parallel and back edges are flush tangent to the **Mast**.

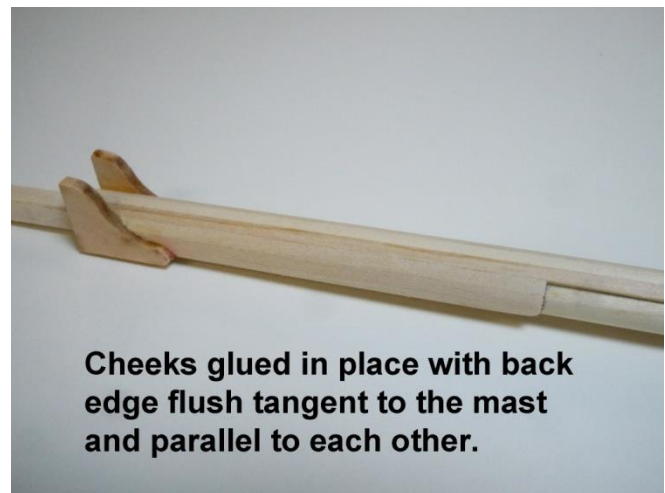
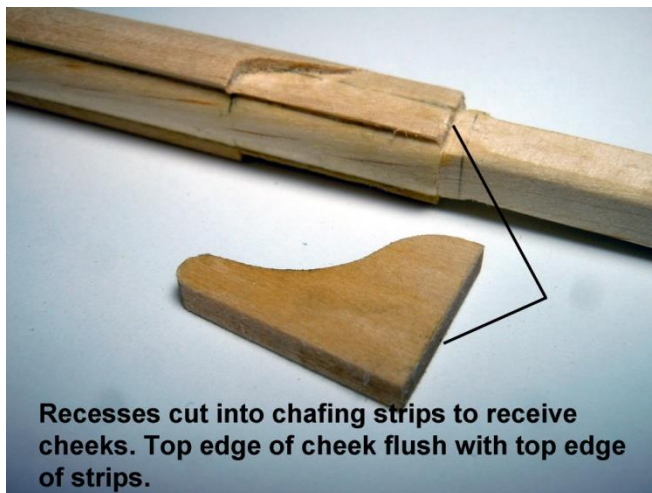

Round Bands: Start at the Spar Deck reference line measure up 3/4" for the lowest **Round Band** location and then mark sixteen (16) **Band** locations 1/2" on center around the **Mast** to each side of the **Chafing Fish** strips. **Mast reinforcing Bands** are made using the 1/64" x 1/16" x 12" **Brass Strip**. Start by forming the larger size **Bands** forming one end around a smaller dowel as a mandrel and then press fit to **Mast** position and mark the location to be cut with a pencil to be cut. Due to the **Mast** taper each **Band** position will be a different size. If a larger **Band** is cut too short, just cut to fit a smaller size **Band**. Use CA glue to glue the **Bands** in position as seen in the picture on the next page.

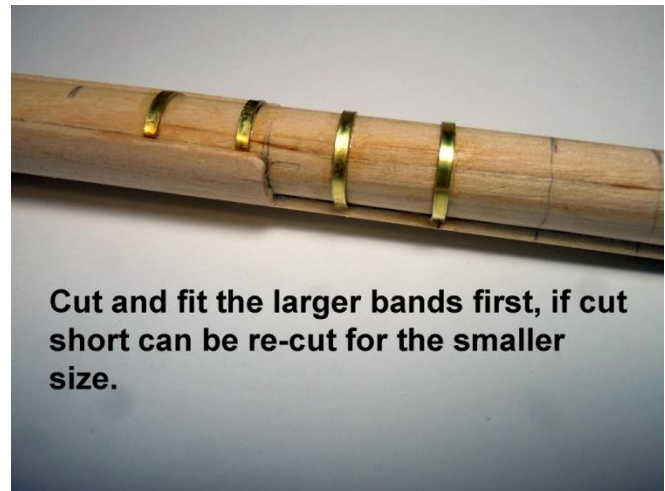
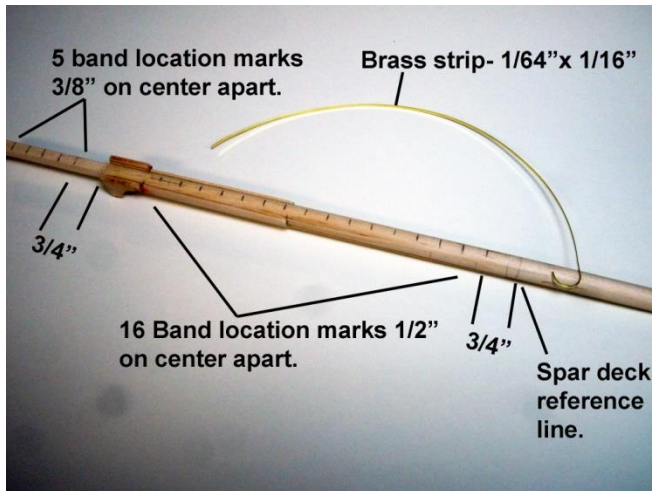

Cut and fit the larger bands first, if cut short can be re-cut for the smaller size.

Square Bands: Start at the top edge of the **Cheeks** and measure up $3/4$ " for the lowest **Square Band** location then mark 5 **Band** locations $3/8$ " on center around all four (4) sides of the **Mast**. Use small square pliers to bend and form the **Square Bands** with the joints being on the backside of the **Mast**. If you can solder the joints in place and file smooth. Otherwise use CA to glue them in place as seen in the picture below.

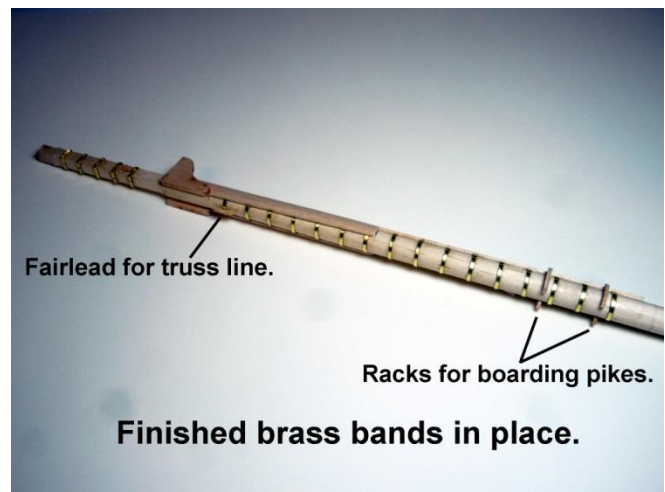
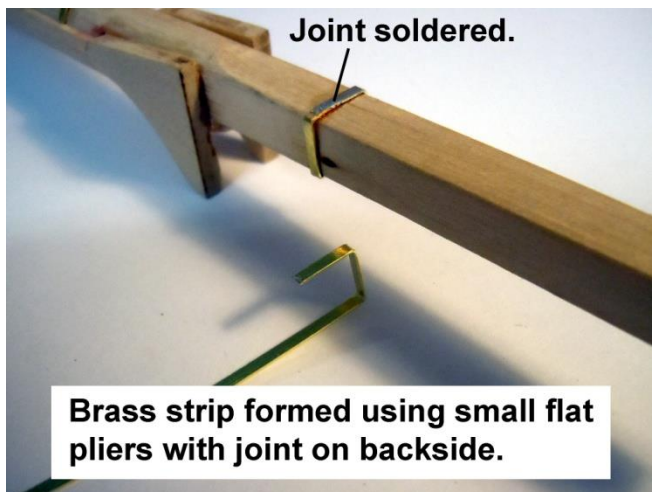

Mast Fittings: Remove and clean the laser cut edges of the one (1) lower **Mast Fairlead**; **Boarding Pike Racks** six (6) parts and six (6) **Mast Chocks**. The **Fairlead** is centered on the stern side of the **Mast** on center straddling the top **Band** with the notch on the **Band**. The **Boarding Pike Racks** require the two (2) bottom **Racks** to have the two (2) **Bottom** parts glued to each other to provide indexing holes for the bottom of the **Pikes**. The lower **Racks** with bottoms are glued on the sides of the **Mast** on center 1" up from the **Spar Deck** reference line and the upper **Rack** 1" above the lower **Rack** as seen in the picture above. The **Chocks** are glued centered on the port and starboard sides with the lower two (2) $1/2$ " above the upper **Boarding Pike Racks** centered between the **Bands**. The next two (2) $3-1/2$ " above the first two (2) and the third pair with their top edge aligned with the lower hole in the **Fairlead**. See picture on the next page. Before painting the **Mast** the brass strips must be primed first for proper paint adhesion. Paint the **Lower Mast** all white except the top $1/4$ " that the **Mast Cap** will fit onto and the top surfaces of the **Cheeks** that the **Trestle Trees** will glue upon.

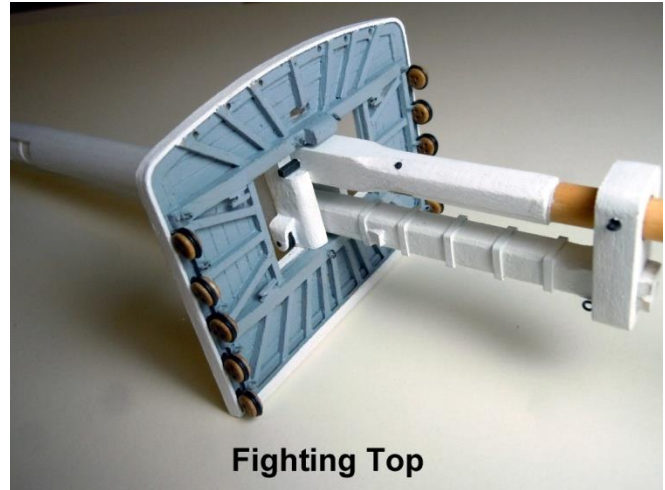
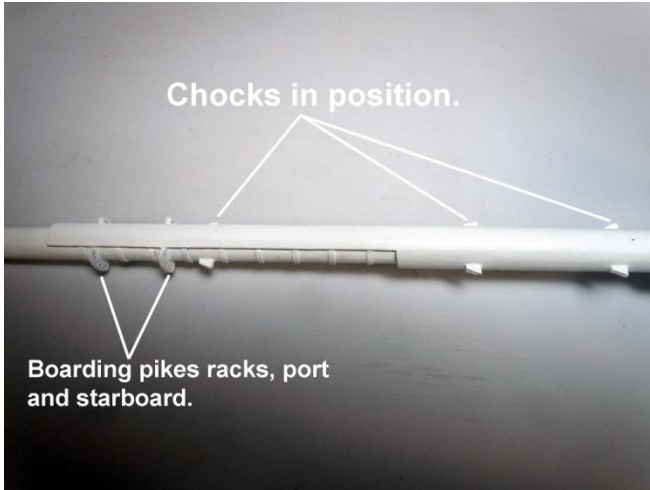

Fighting Top: To build the **Fighting Top** as seen in the picture above will combine the use of laser cut parts and wood strip stock. Study both the following pictures and the plans before starting to build. Glue the **Fighting Top Frame** to the **Fighting Top Platform** and take care handling the **Frame** due to it being 1/32" thick and delicate and prone to breaking with the grain. **Note:** leave the center area of the **Fighting Top Platform** in place to use the center mark when adding **Timbers**. See picture below. Yellow glue would be best to use for a better painted finish on the final parts. Glue in place the two (2) laser cut **Upper Cross Trees** aligned flush with the edges of center area top and bottom laser cut edges for the **Platform** opening and centered port to starboard. Next add two (2) 1/16" x 1/16" **Timbers** between the **Crosstrees** flush with the laser cut sides. Using a 1/16" x 1/16" strip for **Timbers** cut and fit individual **Timbers** using the center mark as reference to set each angle of the **Timbers**. The top edge **Timbers** will need to be notched to fit over the **Frame** as seen in the picture below. The top (looking at the pictures below) **Timbers** are aligned from the center mark to just outboard of the holes in the **Frame**. The side **Timbers** are from the corners and center to the center mark. The bottom **Timber** locations can be located by using the **Plans** for best results and start at the outboard corners first. Glue four (4) small **Cleats** in place on the inboard surfaces of the **Crosstrees** next to the **Timbers** on the edge of the opening. Next remove and file quarter round the **Upper Crosstree Bolster** and glue in place centered on the small oval opening with the rounded surface facing the oval opening. See the picture on the next page.

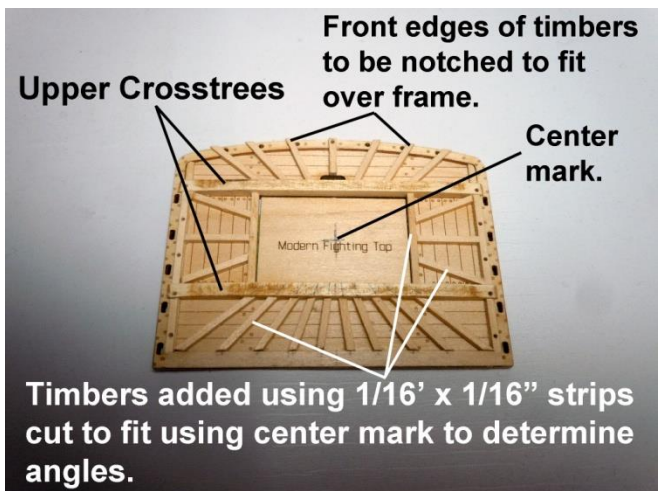
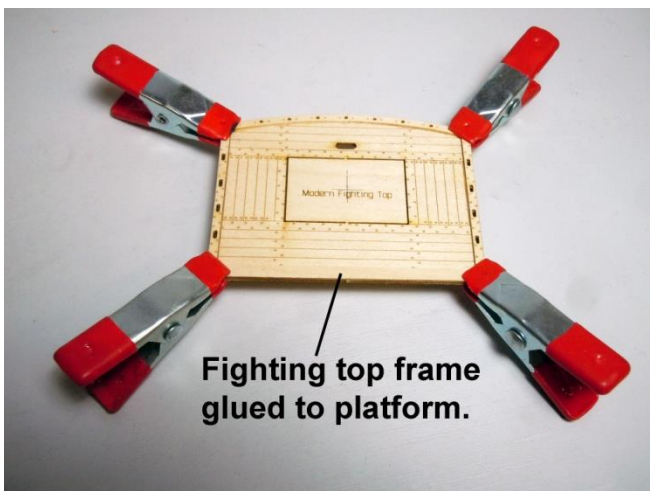

On the underside glue the forward **Lower Crosstree** in place centered port to starboard and flush with the removed center area part edges to be below the **Upper Crosstree**. Remove and clean the two (2) laser cut **Trestle Trees** of char and test fit to the **Forward Crosstree** indexing the forward notch on the **Trestle Tree**. Now index and glue the aft **Lower Crosstree** using the **Trestle Trees** as locators; ideally the aft **Crosstree** will be flush with the edges of the opening. Cut and fit the **Timbers** at the ends of the **Lower Crosstrees** centered on the holes using 1/32" x 1/16" wood strip. Locate the two (2) laser cut **Thumb Cleats** and two cast metal **Sheaves** and using the **Sheaves** as a guides mark and then drill the .024" axle holes for the **7mm Nails**. Sand the open end corners half round to follow the perimeter of the **Sheaves**. Using the **Nails** as guides into the laser cut holes in the **Trestle Trees** glue the **Thumb Cleats** in place. Remove the two (2) **Fighting Top Bolsters** and cut/file quarter round and glue onto the top surface of the **Trestle Trees** aligned with the edge of the aft notch as seen in the picture below.

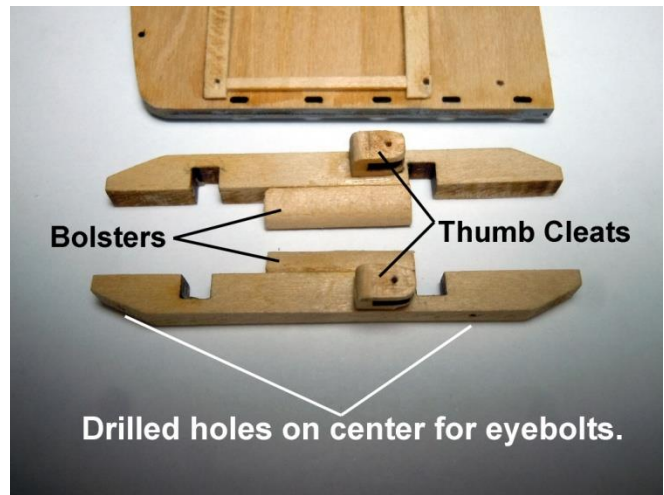
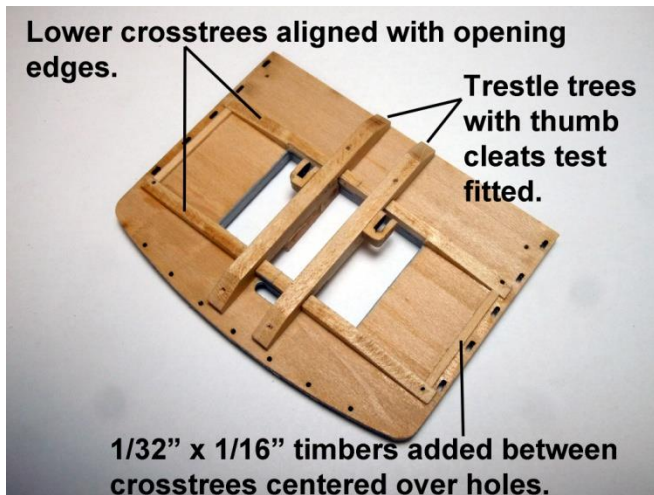

Using **Deck Light Gray MS4825** paint the upper surfaces of the **Fighting Top** except for the gluing area of the **Guard Rail** as noted in the picture below. Paint White the two (2) assembled **Trestle Trees** except for the top gluing surfaces. Soak the 1/32" x 1/8" x 9" **Edge Batten** in hot water and then slowly and carefully form around the three sides holding in place with rubber bands and allowing to completely dry. Once dry, paint the **Edge Batten** white and glue in place with bottom edge flush to bottom edge of **Fighting Top**. When glue has set cut the **Batten** ends flush to the stern edge of the **Fighting Top**.

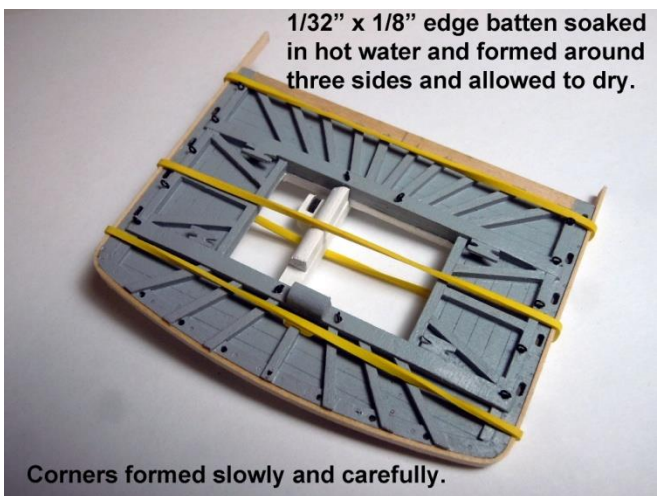

Paint the underside of the **Fighting Top** White taking care not to plug any of the holes with paint.

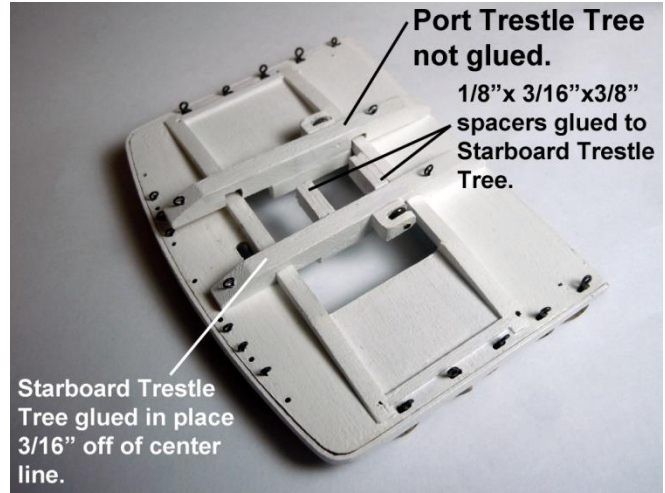
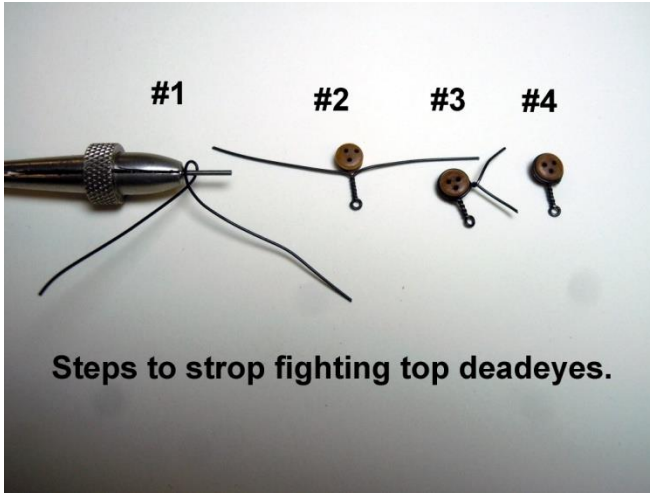

Deadeyes: Strop ten (10) 3/16" **Deadeyes** using the black 28 gauge wire around a 1/32" drill bit shank following the steps seen in the picture above. **Note** the wire twist is to the side of the **Deadeyes** must be trimmed close and filed smooth. Insert the open hole end of the **Deadeyes** into the ten (10) slots along the sides of the **Fighting Top** as seen in the picture above. Also make six (6) Eyebolts and add them to the front edge as seen in the picture above. Now glue the starboard side painted **Trestle Tree** in place; but **do not glue** the port side **Trestle Tree** for now. Then cut two (2) **Spacers** 1/8" x 3/16" x 3/8" and glue one **Spacer** end to the starboard **Trestle Tree** 1/16" from and parallel to the aft **Lower Crosstree**. Glue the second **Spacer** 3/8" from and parallel to the first **Spacer**. Paint the **Spacers** White except for the end glue surfaces. Index the **Fighting Top** onto the **Mast** in position just above the **Cheeks** and now glue the **Port Crosstree** in place by gluing to the end of the **Spacers**. Next glue the **Fighting Top** to the **Cheeks** by applying **Medium CA** to the top surfaces of the **Cheeks**. The **Medium CA** allows a little time for positioning the **Top** 90 degrees square to the **Mast**. Lay the stern edge of the **Top** on a flat surface and use a small square against the square section of the **Mast** and centering the long ends of the **Chaffing Fish** up. Justify the two if necessary to be square. See the picture below.

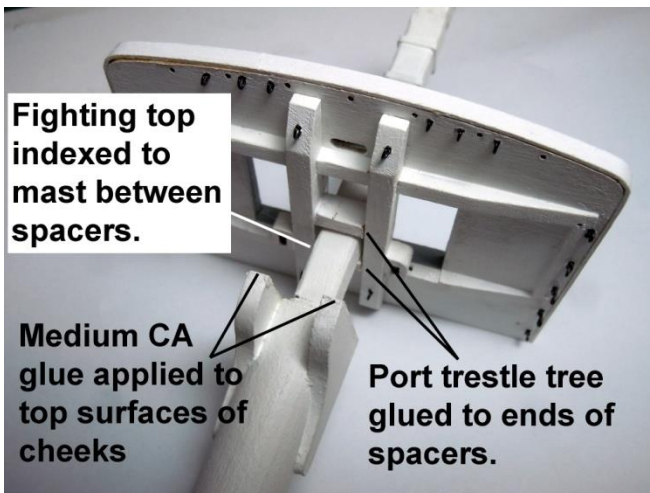

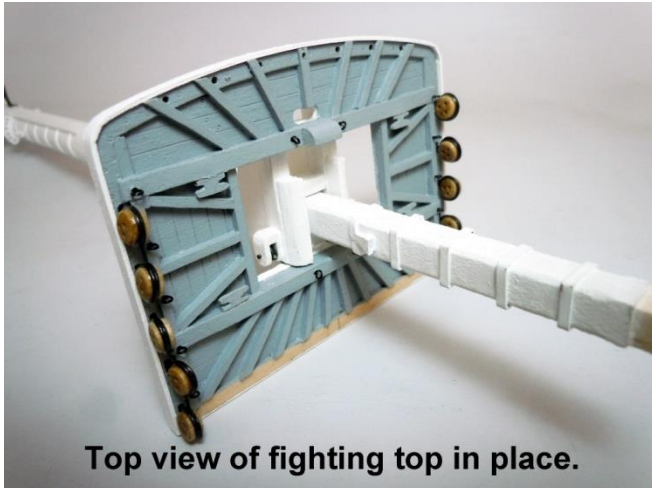

Insert and completely seat the **Mast** into the **Hull Mast Foot** and also making sure the **Mast Surround** is in place. There is no need to glue the **Mast** in place. See picture above.

Before starting to rig the **Shrouds** it is easier to add **Mast** fittings without interference of rigging.

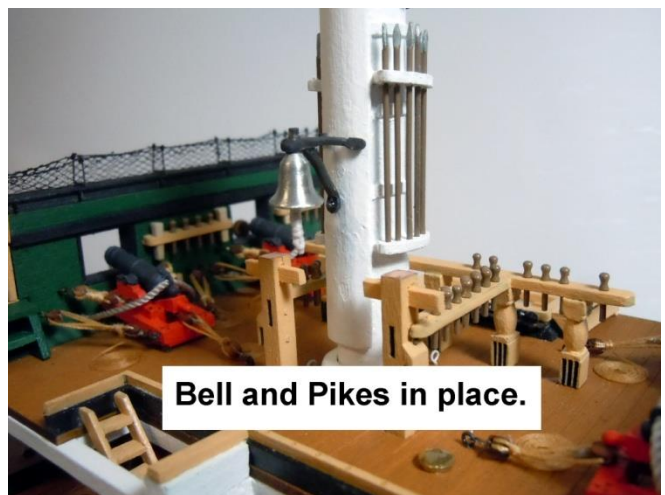
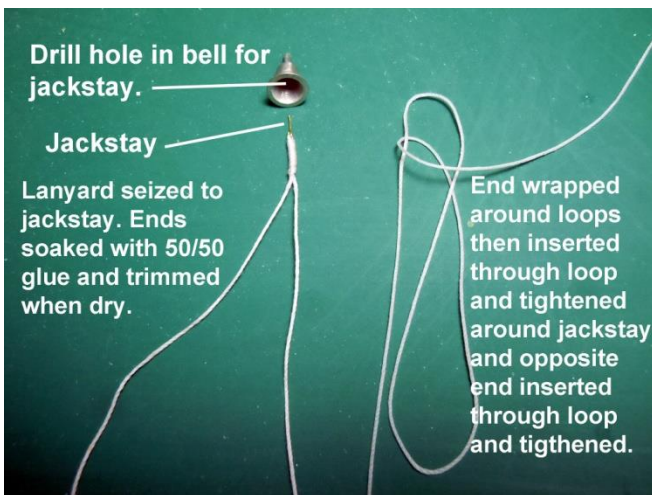

Bell: Clean and polish the cast metal **Bell**. Drill a .020" hole in the center of the **Bell** cavity to receive the trimmed **Jackstay** that will hold the **Lanyard**. The **Lanyard** can be tied using white cotton crochet thread size 20 or 1mm; Beige (1242) can also be used if white thread is not available. Form double loops and with one end wrap back down the loops to form the wrap 1/4" long. Then pass the end through the end loop and pull the thread at the other end to tighten the loop and seize the thread. Do not pull the end loop too tight, just enough to hold the thread at the end of the wrap. Now at the other end loop pull the thread to reduce the size of the loop and seize the **Jackstay** in the loop and tighten enough to hold the **Jackstay**. Soak the long ends of the thread with a 50/50 glue/water mix and when dry trim off the ends. See picture above. Glue the **Jackstay** into the drilled hole in the **Bell** cavity and let glue set. Clean and darken or paint black the **Bell Bracket** and glue to the **Mast** with the two (2) upper **Bracket** arms 1-5/8" above the **Spar Deck** and the third leg pointing down to the deck. Once the **Bracket** and **Bell Lanyard** glue has set; then glue the **Bell** to the **Bracket** by inserting the stem on the **Bell** into the hole on the **Bracket**. Straighten the **Lanyard** to hang down correctly. See picture above.

1/32" x 1-1/4" brass rod end hammered flat with drift punch and then held in pin vise to sharpen to a point.



Boarding Pikes: Cut twelve (12) 1-1/4" lengths of 1/32" brass rod and file the cut ends flat. Using a small drift punch, hammer flat 1/8" of one end to all 12. Index the shaft into a pin vise to hold the **Pike** while filing the hammered flat area into a point. Test fit a **Pike** into all the holes in the **Brackets** on the **Mast** for clearance and/or not inadvertently painted shut. Paint the shafts a Brown color and the tip Metallic Silver. Once paint is dry again carefully tests fit and re-drill holes if necessary for clearance and add the **Pikes** to each hole. See picture on previous page.

Belaying Pins: Prime and paint fifty (50) brass **Belaying Pins** a **Bulwarks Brown MS4817**. Best results can be achieved by spray painting. Once dry add the **Belaying Pins** to holes in the **Fife Rails** and **Racks** on the **Sidewalls**. Make sure to test fit the **Pins** for clearance for them to rest in the hole on the shoulder on the **Pin**. Do not press too hard on the fore and aft arms of the **Fife Rails** to avoid breaking them.

Large Wood Pins: Using the 5/32"x 5/32" wood strip mark a pencil reference line 5/16" from one end on all sides and using these lines now cut a taper from the marks down to the end to a 1/16" square. File/sand the tapers smooth then test fit into one of the **Rack** square holes. If fit is good then cut from the wood strip at 5/16" long or continue sanding until proper fit is attained. Repeat for five (5) additional **Pins**. Staining is optional or one can leave natural wood which is seen in the picture above.

Bobstay Collars: Locate four (4) 9/64" **Bullseyes MS 2464** and cut four (4) 6" Black line (**1210**) and strop the **Bullseyes** and whip the lines 1/8" from the **Bullseyes** using Black thread. Build a rigging fixture with a scrap block of wood, two 1" lengths of brass tube or rod and two small **T-pins**. On edge of block drill two (2) 1/16" holes 1-3/8" apart and mark the centerline between the holes. Insert the brass **Tubes** into the holes. Press one **T-pin** centered between the brass **Tubes** and then the second **T-pin** 1/4" below the first **T-pin**. See the picture on the next page. Pin the stropped **Bullseye** below the center **T-pin** and separate the two lines at the center **T-pin**. Tape one end making sure the intersection of the ropes stays on center; then wrap the second line around the brass **Tube** and bring the end back and tape on top of the first rope end. Now seize and form a loop using Black thread and whip for 1/16". Apply glue to the threads and rope to be cut off to reduce fraying when cut. Repeat and seize the other end and allow glue to set then trim all excess rope and thread away. Remove **Bobstay Collar** from the brass and repeat to have four (4) **Bobstay Collars**. Cut four (4) lengths of Beige line (1242) and seize

one end to a loop on the **Bobstay**, then tie only three (3) the **Bobstay Collars** in place on the **Mast** resting on the **Chocks**. The fourth will be added once the **Shrouds** are in place. See the picture below.

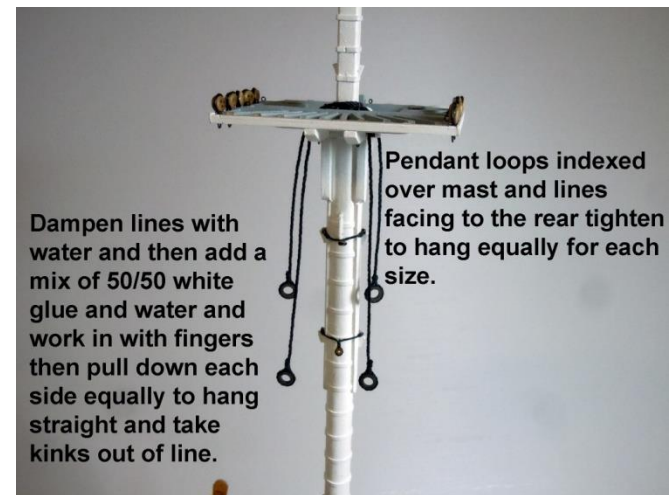
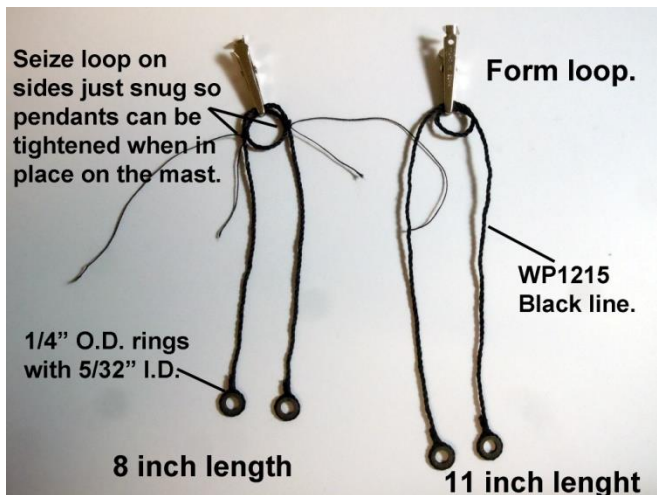
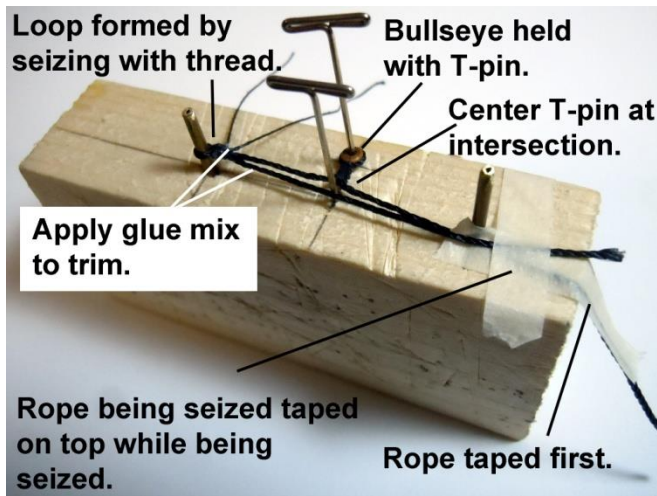

Pendants: Cut two lengths of Black line (**1215**); one at 8" and the second at 11". Next seize 1/4" O.D. and 5/32" I.D. cast metal darkened **Rings** to each end of the two (2) lengths of rope. Then form a loop and seize them with thread (**1218**) in the center of the lengths large enough to fit over the top of the square section of the **Mast**. Position the **Pendants** on the **Mast** with the lines hanging down towards the stern with the long line first and hanging to the rear of the **Thumb Checks** and the shorter hanging forward of the **Thumb Cleats**. Adjust them to hang equally and then using the 50/50 mix of glue and water added to the lines and work in with fingers to hang straight as seen in the picture above.

Shroud Lines: Cut six (6) 24" lengths of (**1215**) Black Line and touch CA glue to the ends to keep from unraveling. These lines for accuracy need to be served; which means wrapped with a thinner thread (**1218**). This can be accomplished with a serving mechanism or on a lathe if one is available. It can be done by hand but would be very tedious. Five (5) inches of the center need to be served for each **Shroud** line; bend the line in half to find the center and back off 2-1/2" to start serving. The setup for the lathe is shown on the next page. If using the lathe serve on the slowest speed.

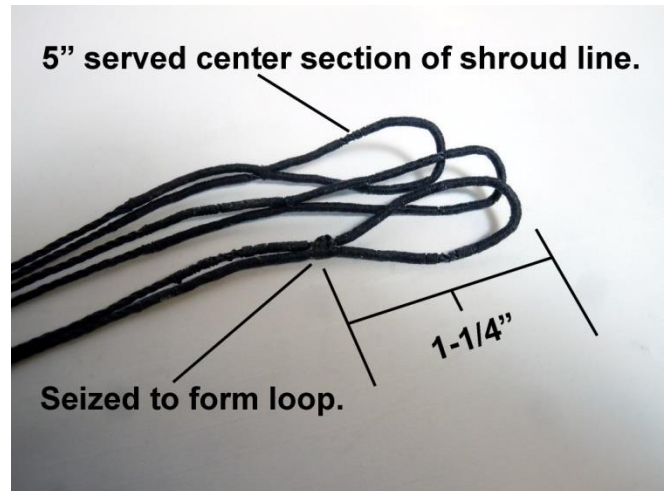
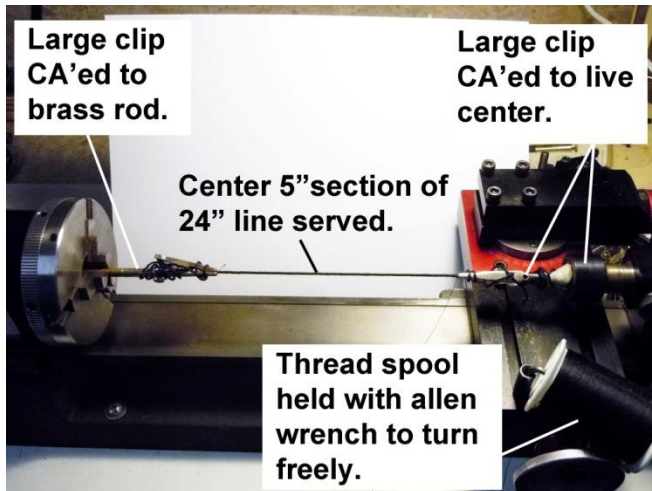

Once the lines are served bend the served sections in half matching the served ends then seize 1-1/4" down from the centers forming loops. Then add a 50/50 water/white glue mix to the lengths of the line and hang suspended by the loops and clamps on the ends for weights to straighten lines and dry.

OPTION: Shrouds and ratlines can be rigged in place on ship or using a "Ratliner" from Model Expo off ship. Both options will be described.

In Place On Ship: Index the loops onto the mast starting with the first on the starboard side and then alternating to port and back until all six (6) are in place. The forward lines towards the bow are the **Lower Mast** tackle fall and are indexed through loops on the **Double Block** seen below. Locate two (2) **Triple** and **Double Blocks** and drill holes to enlarge with a 1/32" drill bit; lines through blocks must be able to move freely when rigging them. Seize a large **Hook** to the **Triple Block** and a small loop with a 8" line (1210) on the **Double Block**; then rig the **Double Block** to the **Triple Block** as seen in picture below.

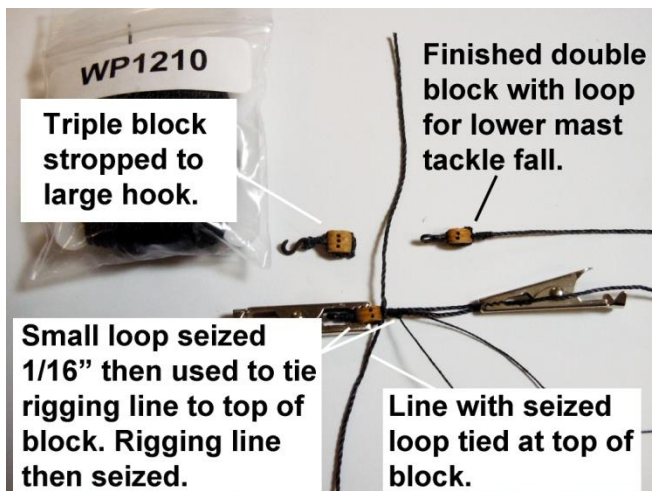

Insert the bow side **Shroud Line** into the small hole on the **Double Block** then engage the **Hook** to the eyebolt in the **Channel** and adjust the rigging (lanyard) lines for a 1-1/4" from the **Channel** to the top of the **Double Block** then bend and seize the **Shroud Line** using **Black (1218)** thin line. Temporarily tie off the bent end of the **Shroud Line** to itself. Then seize the **Shroud Line** just below the second orange line on the **Ratline Spacing Gauge**. Now with the second **Shroud Line** and the **Ratline Spacing**

Gauge made and cut to fit from the plans in place, bend the shroud line around the **Deadeye** with the center on the first orange line and seize around the **Deadeye** and tie the end off on itself. Then using **(1210) Black** line rig the **Deadeye** to align on the first orange line and seize the rigging line to itself just above the top **Deadeye** as seen in the picture on the next page. Repeat for the next four **(4) Shroud Lines**. With all the **Deadeyes** aligned add a drop of mixed glue to each seizing. Using the **Spacing Gauge** add the additional seizing's centered between the lines as seen in the picture below and glue each seizing. Once the glue has completely set; trim off the excess seizing line using a sharp hobby knife blade. Then untie the temporary **Shroud Line** tie off and cut off the excess **Shroud Line** at the top seizing using sharp scissors. Cut two **(2) 1/32" x 1-3/4" Brass Rods** and darken. These **Sheer Poles** are tied just above the **Shroud Line Deadeyes**. The **Deadeyes** are aligned by inserting a **1/8" x 3/8"** wood strip between the **Lanyards** (rigging lines) below the top **Deadeyes**, then add the **Sheer Poles** and lash in place and glue.

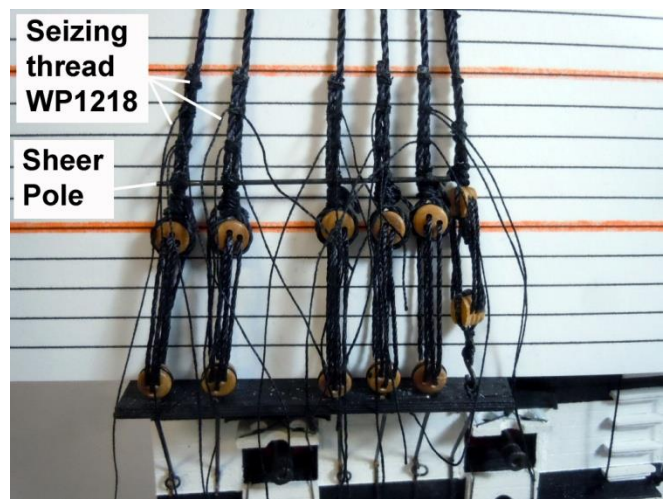
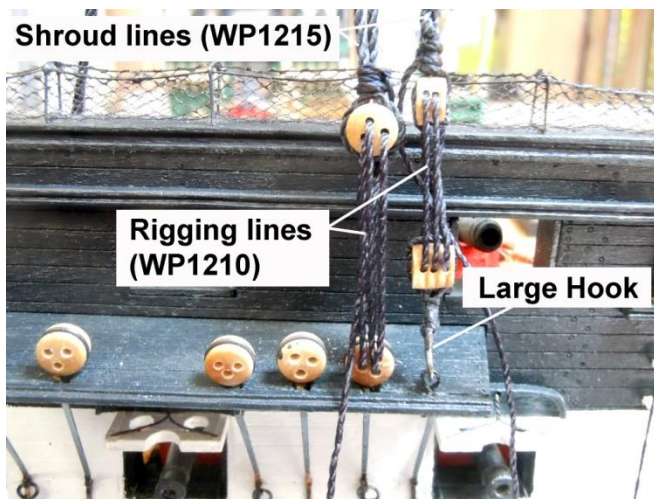

Using **(1210) Black** line add the **Ratlines** on the orange lines first and these lines are tied across all **Shroud Lines** and the lower mast tackle fall line. See picture below. Cut an **18"** length of **Ratline (1210)** and wet with water and slowly pull the line through thumb and index finger creating friction and wetting with water. Twisting will occur and some loosening of the "twist" will happen and this will relax the line and remove the links in the line. Tie the **Ratlines** in place starting at the bottom orange line and working up the **Shrouds** using clove hitches. However, the first and last clove hitch on a run must be ended with a half hitch to keep the clove hitch from unraveling. Once in place add a glue mix to each clove hitch and allow to completely dry and then trim off excess line at ends.

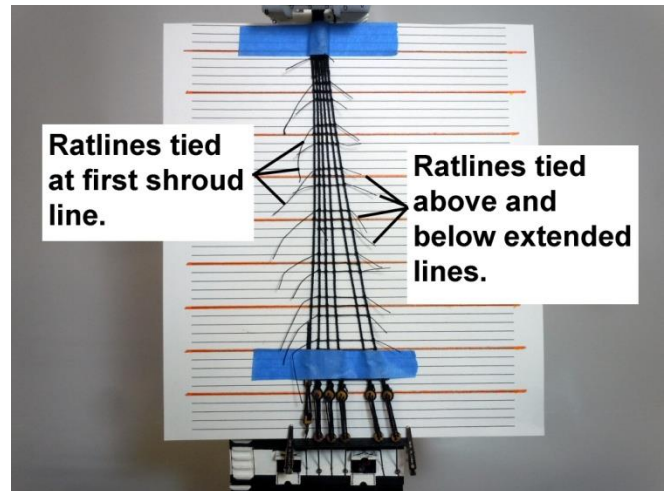
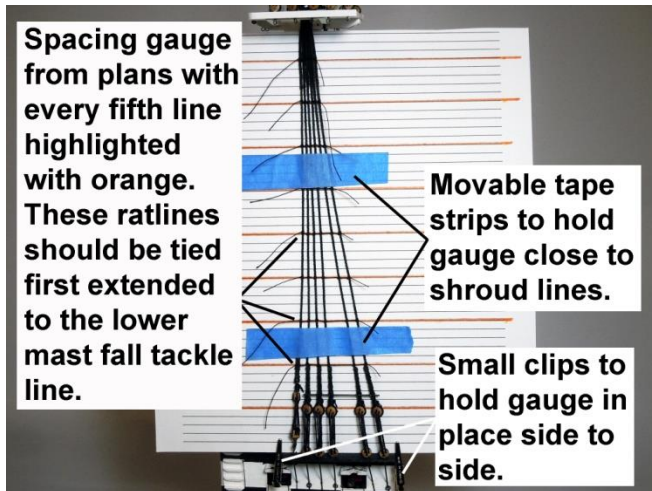

Now tie the **Ratlines** above and below the lines already in place following the same procedure. Finally fill in the balance of the lines working up from the bottom. When cutting off excess line add a touch of the glue mix after the cut has been made to really prevent any unraveling of the end knots.

Using the Ratliner: The below picture shows the tools and materials needed to use the **Ratliner**. Start by indexing the **Shroud Lines** on the upper right hand **Starboard** tab then index the ends in pairs into the small holes across the bottom starting at the second hole and skipping the sixth hole (for gun port) and holding in place with cut off toothpicks. Using **(1210) Black Line** add the first extended Ratline inserted into the fourth hole up from the bottom and tied off on the tabs on the sides. Now add **Ratlines** into every fifth hole up the **Ratliner** for a total of six extended lines. Once each line is in place and adjusted straight add glue mix to each knot and line. These lines will hold the **Shroud Lines** in position while adding the remainder of the **Ratlines**. To start tying on the remaining **Ratlines** clamp the **Aligning Plank** on the fourth hole up and tie a clove hitch seized with a half hitch on the left shroud then moving to the right tie each shroud with a clove hitch and then the last **Shroud** tied with a clove hitch and seized with a half hitch. Adjust line as straight as possible and then add glue mix to all knots and line. Now moving up to each fifth line, add a **Ratline** on the next space above and below the lines. Then starting at the bottom and working up fill in the remaining lines. Working with tweezers is a must when adding the **Ratlines** especially at the top.

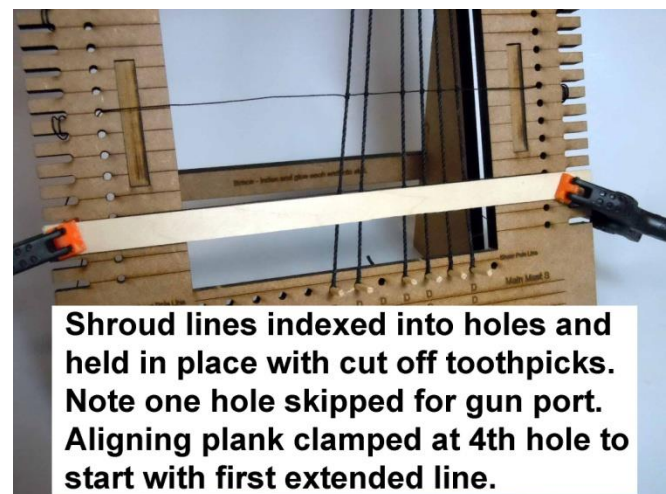

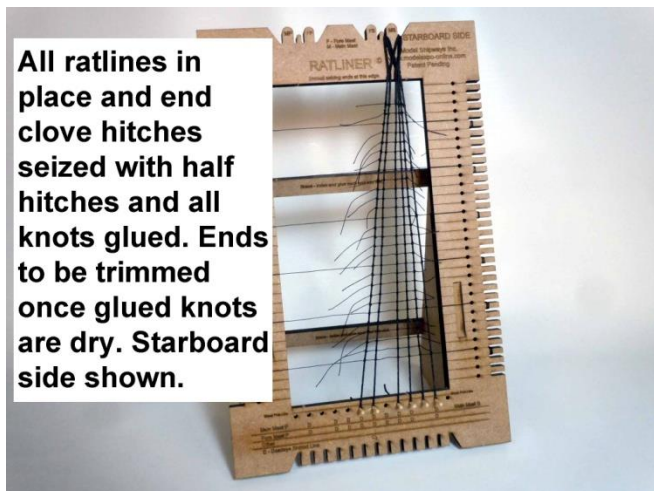

Once all the lines are in place all knots glued and dried carefully trim off all excess ends with a sharp hobby knife. Then remove toothpicks and lift completed **Ratlines** off of **Ratliner**. Now repeat the process for the Port side using the Port tab for the **Shroud** loops. These **Ratline** units must be installed at the same time by carefully inserting the top **Shroud** loops up through the opening at the **Fighting Top** and the **Shroud** loops indexed onto the **Mast** starting with the Starboard bow loop then the Port bow loop and alternating back and forth until all are in place. They must also be positioned forward of the **Cheeks**. Once both sides are in place add the **Blocks, Deadeyes, Lanyards** and **Sheer Poles** as described above at the beginning of the **In Place on Ship** section.

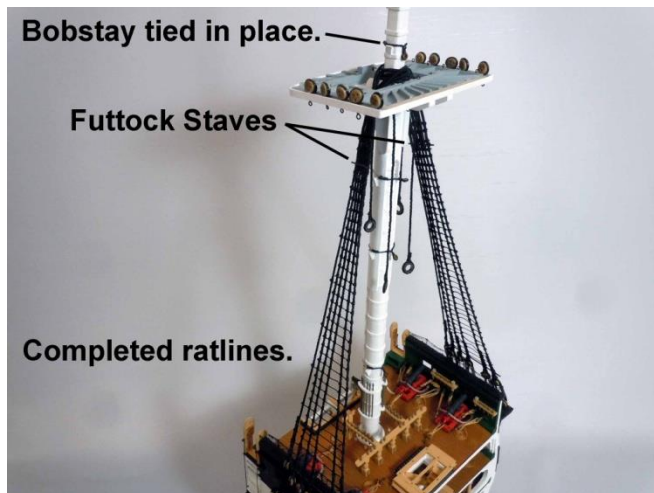
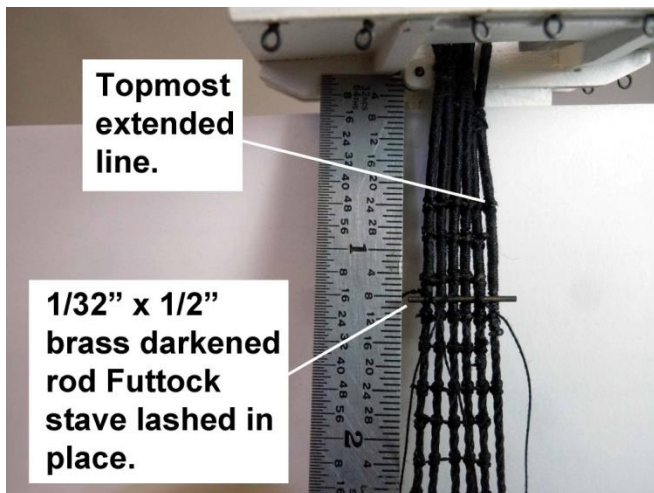

Using two (2) 1/32" x 1/2" darkened **Brass Rods** and lash to the **Shrouds** 1-1/4" down from the **Fighting Top**, these are **Futtock Staves**. Next add the fourth **Bobstay** that was tied earlier with the others to the chocks above the **Fighting Top** on the square section of the **Mast** as seen in the picture above.

Futtock Shrouds, Extensions and Bentinck: Gather the following cast metal parts; photo etched parts and lines 1210; 1242; 1241 and 1218 seizing threads. Wood **Bullseyes** WP2462 (4); cast metal **Thimbles** - 5/32" (10); **Thimbles** - 3/16" (22); small photo etched hooks (12).

Cut twenty (20) 4" lengths of (1210) **Black** line and harden the ends with CA to stop unraveling and for easier indexing later. Seize 3/16" diameter **Thimbles** to one end of ten (10) of the 4" lines as seen in

the picture on the next page. Remove ten (10) photo-etched small **Hooks** and file smooth the burrs left on the **Hooks**. Next index a line end through the hole in a small **Hook** with a 1" lead end then form a loop and seize the **Hook**. Next, form the end lead around a 5/32" diameter **Thimble** and seize the **Thimble** on the line below the **Hook** as seen in the picture below. Using ten (10) of the lines with the 3/16" **Thimbles** cut the CA'ed ends at angles for inserting between the shroud lines above the **Futtock Stave** from the inside then back through below the **Futtock Stave** then back through above the **Futtock Stave** and pull the **Thimble** on the inside tight against the **Futtock Stave** starting at the bow end of the **Shroud** lines. Next insert the end of the line back through above the **Futtock Stave** forming a loop to add and seize a 3/16" **Thimble** on the line tight against the **Futtock Stave** on the outside. See the picture below. It will be easier if one adds a clove hitch to the loop before adding the **Thimble**.

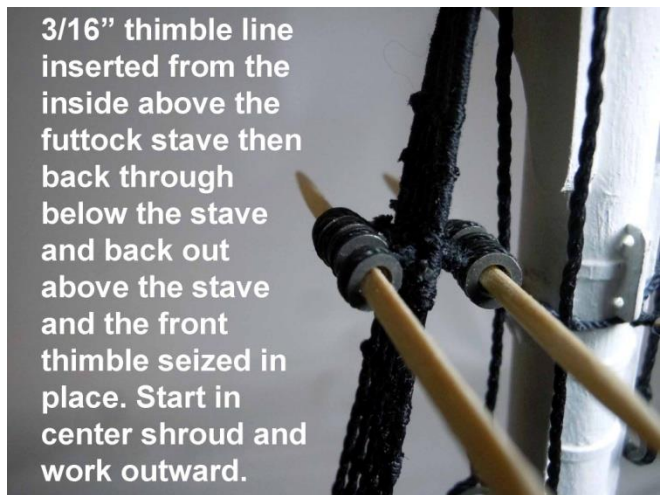
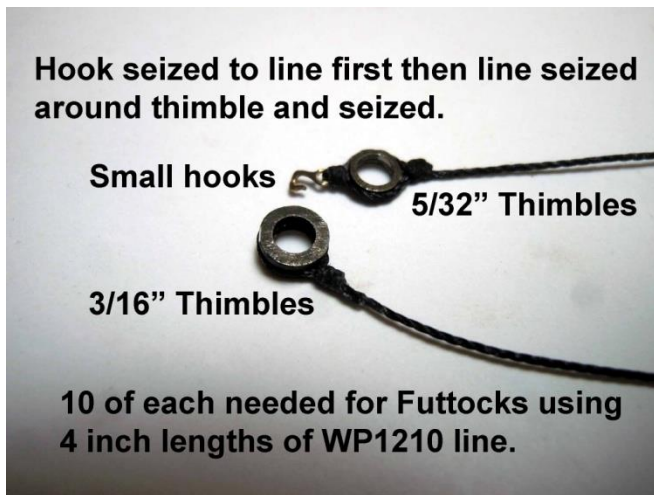

Once the twenty (20) **Thimbles** are seized to the **Futtock Staves** index the **Hook** on a **Deadeye** loop and insert the loose end through the **Thimble** hole and seize with the line being taut starting on the bow end and the seizing glued. See picture below. Repeat for the balance of the lines with **Hooks**.

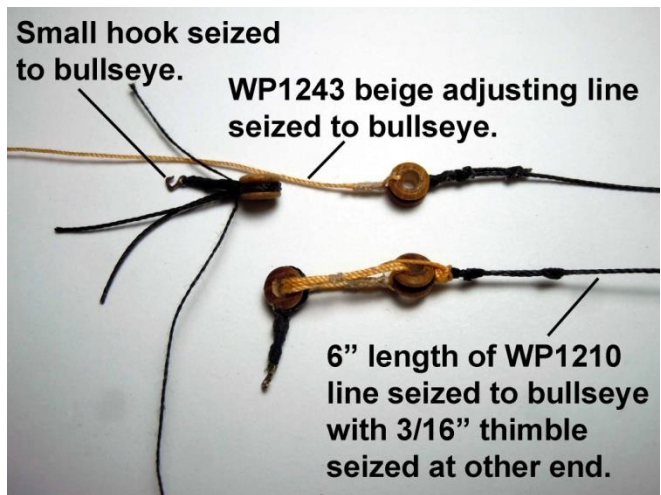
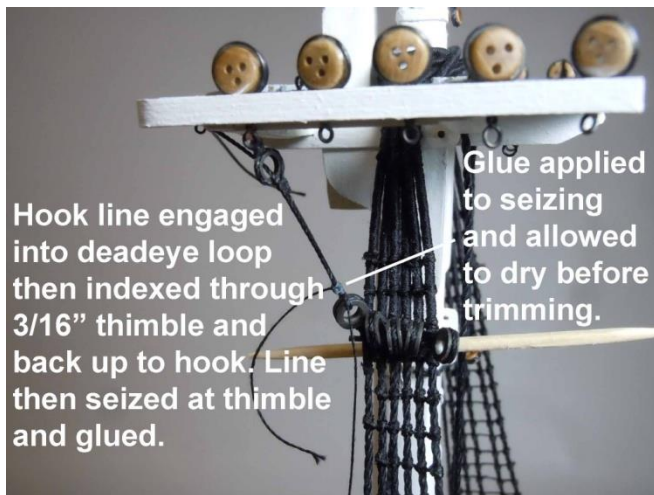

Bentinck: The **Bentincks** are lines from the **Eyebolts** in the **Waterways** with adjusting lines rigged to **Bullseyes** up to **Thimbles**. Use (1210) **Black** line and seize two small **Hooks** with a 1/4" lead between the **Hooks** and the **Bullseyes**. See the picture above. Cut two 7" (1210) **Black** lines and at one end seize a 3/16" darkened **Thimble** and a 3/16" **Bullseye** at the other end. Now using two 6" (1242) **Beige**

lines and seize one end to the **Bullseyes** at the ends of the 6' line with the **Thimble** on the other end. Index the line through the **Bullseye** with the **Hook** and up through the **Bullseyes** seized to the line a couple of times and lash the line above the Black line seized to the **Bullseye**. See the picture on the previous page. Engage the **Bentinck Hooks** onto the **Eyebolts** on the waterway between the Spar Deck **Carronades**; then using thread tie off the **Thimbles** center deadeye on the **Fighting Top** to just hold in place temporarily. Using a 5" length of (1210) Black line seize the center inside **Thimble** on the port side **Stave** first then seize the end to the **Bentinck Thimble** tied off with the thread leading up from the Starboard (opposite) side. Make sure the line is taut and then remove the temporary thread. Next using an 8" length of line seize the adjacent (Stern) **Thimble** from center index through the **Bentinck Thimble** and then seize the adjacent (Bow) **Thimble**. Make sure the line is taut and add glue mix to seizing. Repeat for the outboard stave **Thimbles** and then repeat all for the opposite side. Once both **Bentinck** lines are secure, carefully add toothpicks (trim if necessary) to align together and then add the ratlines to each side. Set seized knot with glue mix and trim the ends. See pictures below. This should complete the lower mast assembly.

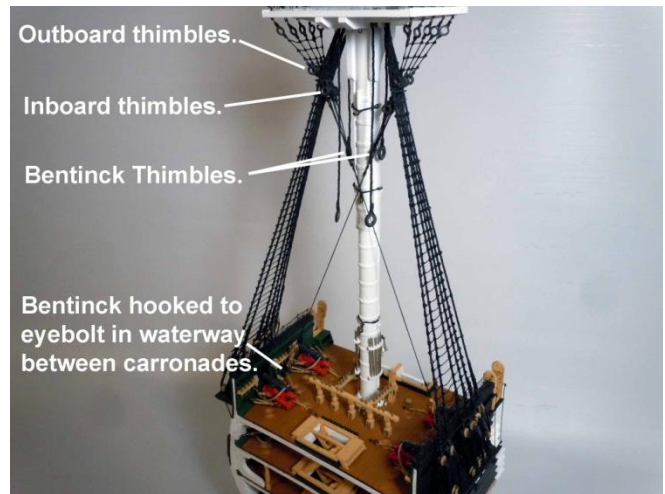

BUILDING THE MAIN TOPMAST:

The **Topmast** is built using two pieces of wood stock; 1/4" x 7-3/4" wood dowel and a 5/16" square x 2-7/8" wood strip. The first is to carve or turn if you have a lathe a 3/16" x 1/2" peg on the end of the 1/4" wood dowel and then drill a 3/16" hole into the end of the wood block to receive the peg. Test fit the peg to make sure the hole is deep enough for the dowel shoulder to seat squarely on the wood stock and then glue in place. With a sanding block; sand a slight taper on the dowel from a 1/4" at the shoulder down to 7/32" diameter at the top of the **Mast**. Next, with the **Mast** assembly laying on a flat surface, mark two lines down from the top one at 5/32" and the second at 1-3/8"; then a third 7/8" down from the last. Mark the top, bottom and side centerlines from the 1-3/8" line up to the top. These centerlines will be reference lines for carving the 3/16" flat sides. On the lower 5/16" square stock mark a line around the sides at 1-1/2" and then mark eight (8) lines 1/16" in from the four (4) edges. Using these lines and starting at the 1-1/2" lines carefully carve from the line to the shoulder forming an octagon section as seen in the picture on the next page. Mark and drill a 1/16" hole 11/16" up from the bottom of the **Mast** on one side and drill completely through. Now carefully using a small square file make the hole square working from both sides. This will be the **Fid** hole and the fid can be carved from 1/16" x 3/4" strip to test fit into the hole. The **Fid** can be painted Black. Moving to the top of the **Mast** carefully carve the

upper 1-3/8" into a 3/16" square section using a small square to check the sides on a flat surface to be the same as the lower section and use the centerlines as reference when carving the sides flat. Next carve the 7/8" octagon section below the 3/16" square section. A small flat file can help true up the flats on the octagon. Cut 5/32" down from the top and carve 1/8" square for the **Topmast Cap** to press fit onto. Stain and paint the Topmast per the plans and pictures.

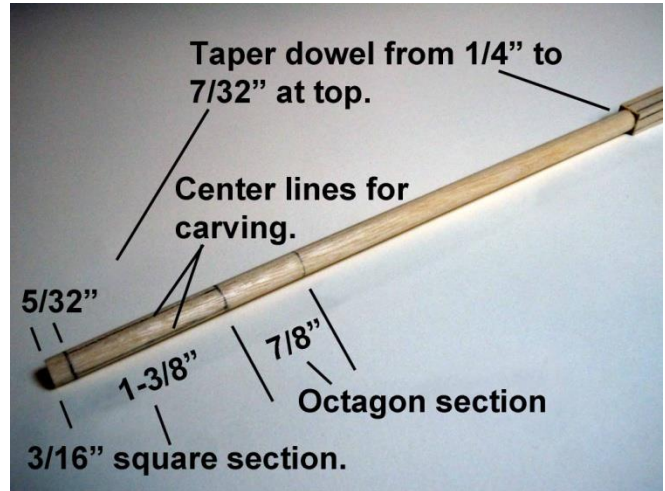
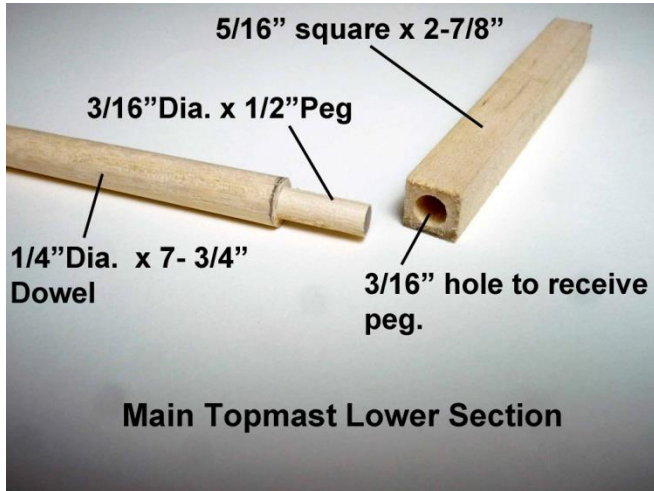

Locate the laser cut **Lower Mast Caps** (2) and **Spacers** (2) and clean all edges of char. First glue the **Caps** together, now glue the **Spacers** with the edges aligning to the edges of the square hole fore and aft. Mark and drill five (5) 1/32" holes for **Eyebolts**; two (2) on the bottom corners, one (1) centered on the back and two (2) on the forward sides centered and aligned with the front edge of the round hole. Paint the **Lower Mast Cap** assembly White. Make the **Eyebolts** using Black annealed 28 gauge wire and add the **Eyebolts** to the drilled holes as seen below and on the next page.

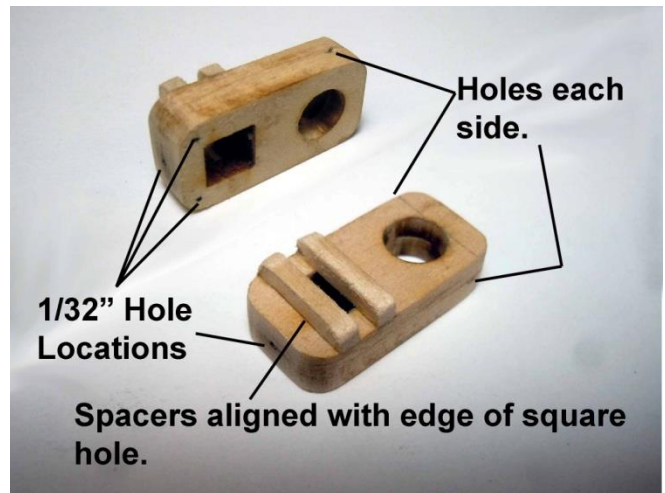
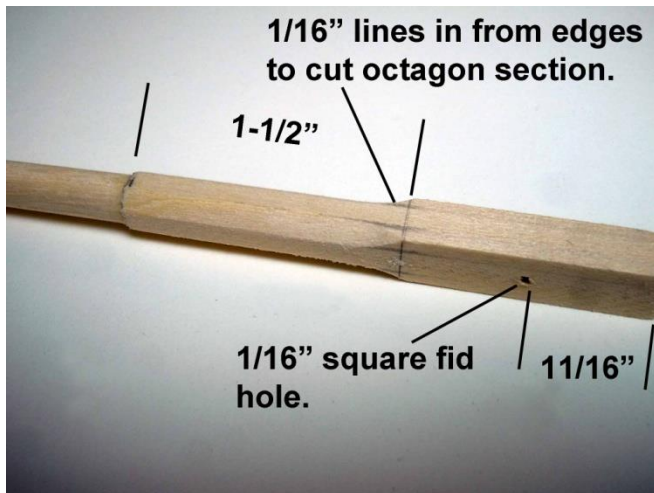

Test fit the painted **Lower Mast Cap** onto the top of the **Lower Mast** for a press fit. Adjust if necessary. Slip the painted **Lower Mast Cap** onto the **Topmast** using the round hole. The **Cap MUST Be** slipped on the **Topmast** before proceeding and adding the following parts to the **Topmast**.

Locate and remove excess char from the **Topmast Cap** (1); **Cheek Blocks** (2); **Cheeks** (2); **Topmast Wedges** (2). On the octagon section glue the two (2) **Cheeks** to the sides with the top aligned with the cut to the square section. Now add the two (2) **Wedges** between the **Cheeks** with the top edges

aligned with the top edges of the **Cheeks**. See the picture below. Next press the **Cap** in place and carefully add the **Cheek Blocks** onto the sides of the square section touching the underside of the Cap. **DO NOT GLUE** the **Cheek Blocks** to the **Cap**. Once glue has set drill .020" holes centered on the slots for pins to be the **Sheave** axles.

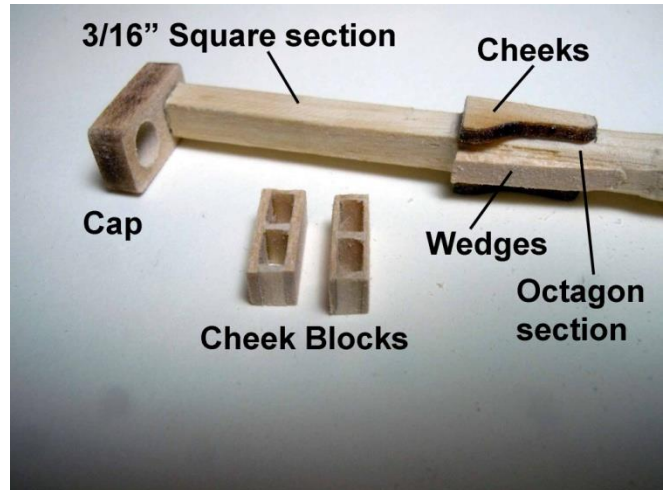
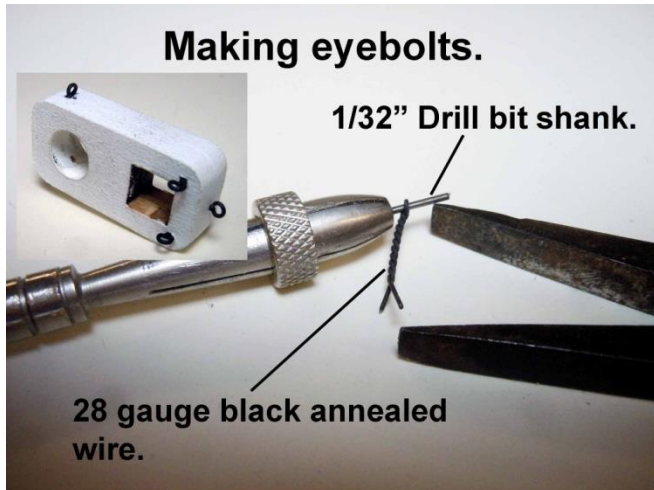

Crosstrees: Locate the laser cut **Topmast Trestle Trees** (2) and **Topmast Cross Trees** (3) **Tip:** Add thin CA glue to the ends of the **Crosstrees** to harden them since they are fragile. Carefully remove char from all edges of parts. Glue the **Trestle Trees** to the sides of the square section on top of the **Cheeks** making sure the notches align with the fore and aft surfaces of the square section to receive the **Cross Trees**. Carefully drill the 1/32" holes at the stern ends of the **Cross Trees** in case they were closed by CA. Now add the **Cross Trees** centered on the **Topmast** with the longest added at the rear notch to the aft of the **Topmast**. If adjustment is needed to match the notches trim the square section surfaces not the **Cross Trees**. Then add the center **Cross Tree** in the notches against the front surface of the square section and add the forward **Cross Tree**. Carve the laser cut **Bolsters** and add them to the top of the **Cross Trees**. Paint White the **Topmast**; **Cross Trees** and **Cap**. Then add the four (4) darkened **Sheaves** to the slots and add axle pins cut to length and paint pins White. See picture below.

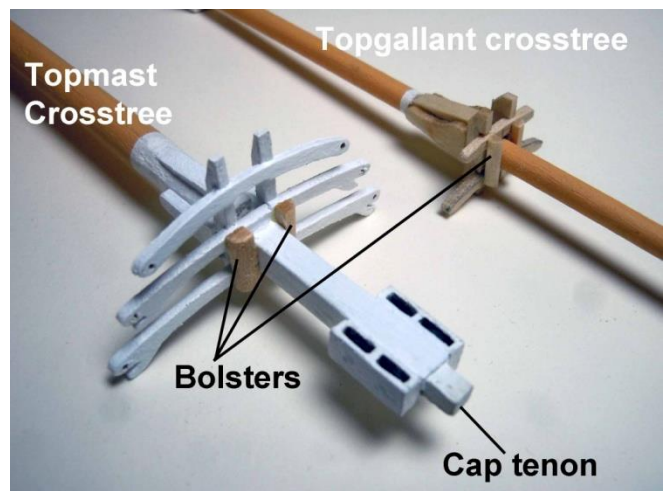
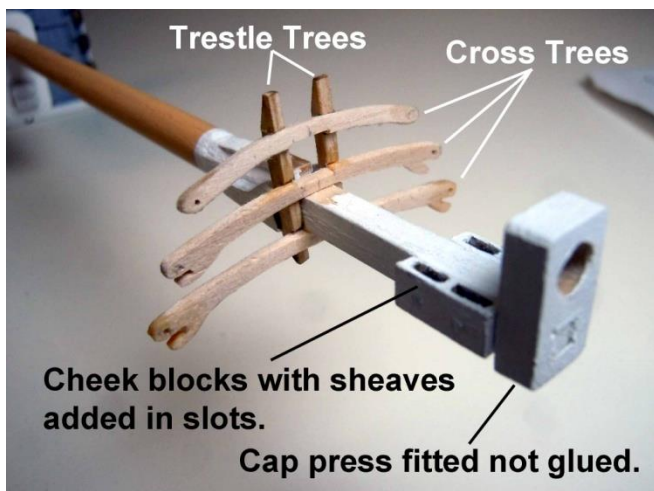

Next building the **Topgallant** is recommended due to the similarities of the **Topmast** before starting the

shrouds for the **Topmast**. Keep in mind to Natural stain mast sections and Yards first and then apply paint.

BUILDING THE MAIN TOPGALLANT:

The **Topgallant** is built using two pieces of wood stock; 1/4"x 8-3/4" wood dowel and a 1/4" square x 1-5/8" wood strip. First carve or turn if you have a lathe a 3/32" x 1/4" peg on the end of the 1/4" wood dowel and then drill a 3/32" hole into the end of the square wood stock to receive the peg. Test fit the peg to make sure the hole is deep enough for the dowel shoulder to seat squarely on the wood stock and then glue in place. With a sanding block; sand a slight taper on the dowel from a 1/4" at the shoulder joint down to 1/8" diameter at the top of the **Topgallant**. Test fit the **Cap** round hole on the taper to assure a proper fit at the glued joint. Mark two (2) lines around the **Topgallant**; one at 1-1/2" and 5" from the top. Slip the **Cap** onto the **Topgallant** down to the joint for now and then at the 5" mark; carve down four (4) 9/16" flat sides matching the lower square stock laying on a flat surface. Locate and clean the excess char from the following parts: two (2) **Topgallant Cheeks**; two (2) **Topgallant Wedges**; two (2) **Topgallant Trestles**; two (2) **Topgallant Crosstrees**; two (2) **Bolsters** and one (1) **Truck**. Glue the two (2) **Topgallant Cheeks** in place on the sides and then the two (2) **Topgallant Wedges** aligned to the top of the **Cheeks**. Cut flat the two (2) sides where the **Trestles** will meet the **Topgallant** then glue the two (2) **Trestles** on top of the **Cheeks** with the notches aligning fore and aft to receive the **Crosstrees**. Next glue the two (2) quarter round **Bolsters** in place on top of the **Trestles**. Drill two (2) .020" holes in the flat stern ends of the **Trestles** to receive ladder eyebolts. Carefully drill open the holes at the end of the **Crosstrees** to remove char. Glue the **Crosstrees** in the notches centered on the **Topgallant**. See the picture below.

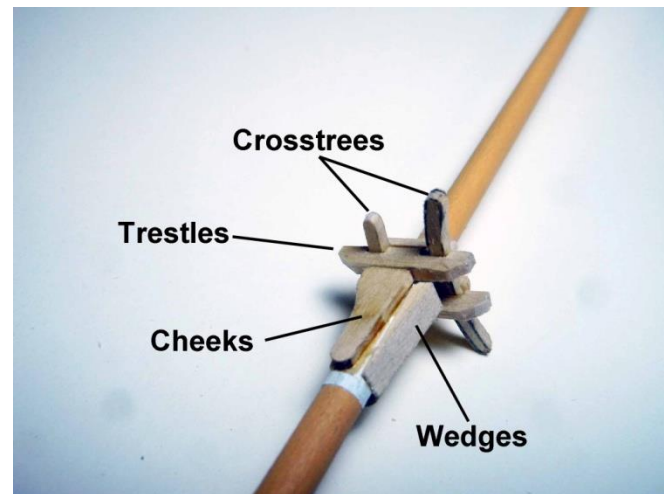
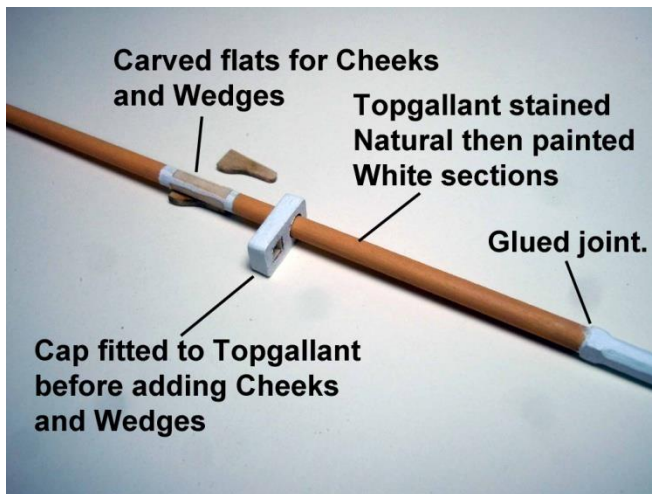

Cut 1/4" flats on the sides of the **Topgallant** down from the 1-1/2" mark from the top. Cut four (4) 1/4" x 1/4" x 1/8" squares from scrap from the laser cut sheet and glue two (2) to the sides. Then cut and fit pieces to fill the gaps front and rear. See picture on the next page. Once glue has set cut down from the top edges and cut an octagon shape around the shoulder. Drill a .020" hole in the top of the **Topgallant** to receive a pin inserted through the hole in the **Truck**. Sand the **Truck** perimeter half round, then glue in place with the pin. At the lower square section add two (2) marks around the perimeter 1/8" down from the joint line and 3/4" up from the bottom. Now on the corners carve flats down the edges to form an octagon section. Now drill a 1/16" hole up 7/16" up from the bottom on the sides and cut square to

receive the **Fid**. Now drill two (2) adjacent $1/16$ " holes on the diagonal centered $7/8$ " up from the bottom and cut to an oval completely through the **Topgallant**. Stain Natural the round portions between the joint and **Crosstree** and the **Crosstree** to the upper **Shoulder**. Paint White the square portion the bottom to the joint, the **Crosstree**, the upper **Shoulder** to the top including the **Truck**. Seize a single **3mm Block** and lash to the top just below the **Truck**. Using **(1210) Black** line tie the **Monkey Rope** with common overhand knot at $3/16$ " intervals the length needed between the **Crosstree** and the upper **Shoulder**. See the picture below.

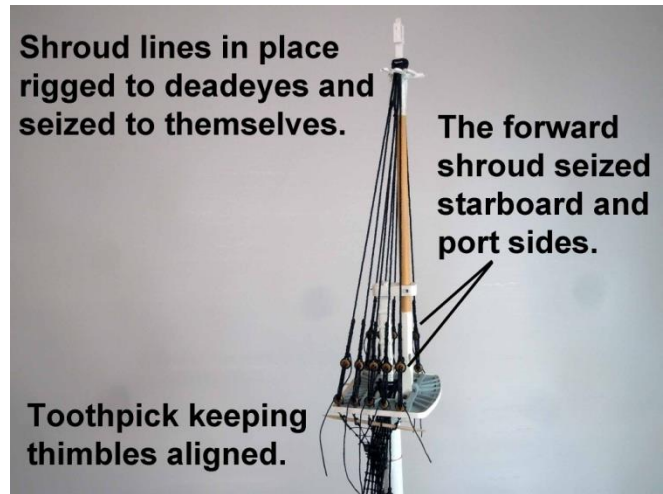
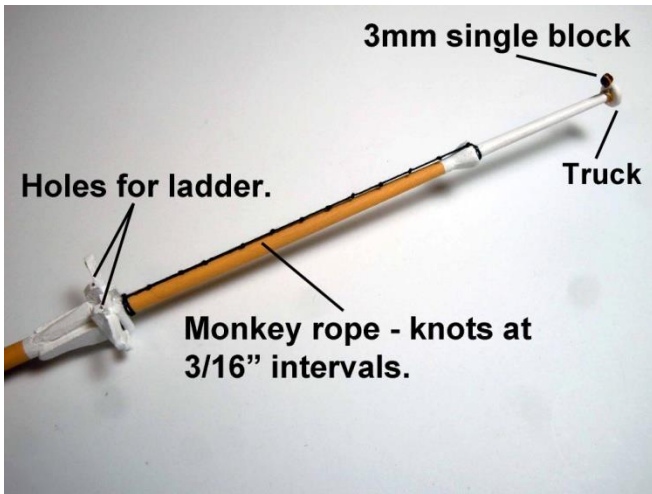
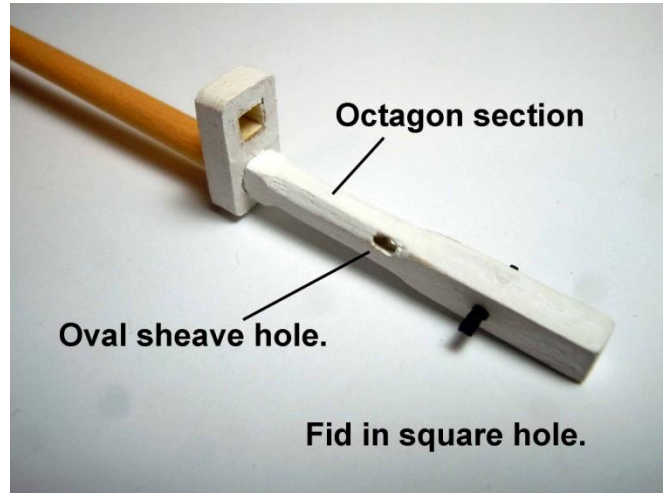
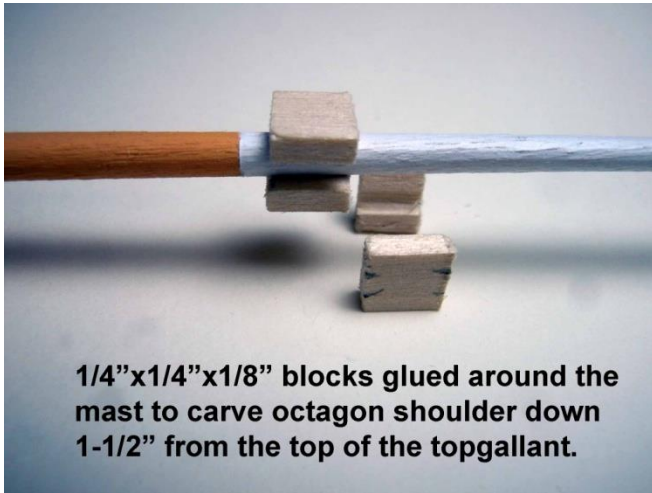

Insert the assembled and stained/painted **Topmast** into the forward opening of the **Fighting Top** making sure the centered **Fid** seats down on the **Trestles** just ahead of the **Bolsters**. Then carefully index the **Cap** onto the square **Tenon** on top of the **Lower Mast**.

TOPMAST SHROUDS: The **Topmast Shrouds** will follow a similar process of rigging with the **Ratlines** as the **Lower Mast** just a couple of different details. Unlike the **Lower Mast** these are a complete set of shrouds.

Shroud Lines: Cut six (6) 18" lengths of **(1215) Black** line and touch CA glue to the ends to keep from unraveling. Three (3) inches of the center need to be served for each shroud line; bend the line in half

to find the center and back off 1-1/2" to start serving using the same method as the **Lower Mast**. The first **Shroud** line is seized in a loop centered on the served section with the seizing knot facing forward to the bow and the line positioned both port and starboard sides. This loop must be seized in place due to the larger size caused by the **Cheek Blocks**. Add the additional served **Shroud Lines** starting on the starboard side and alternating back and forth. Now add the ten (10) **Deadeyes** using the same process previously used. Next rig the **Shroud Line Deadeyes** to the **Channel Deadeyes**. Cut, fit and clip the **Ratline Spacing Gauge** as seen in the picture below and mark the orange lines for reference starting at the third line from the bottom and then every fifth one. Note that the **Sheer Poles** will align on the orange line above the shroud line **Deadeyes**. Cut, fit and seize two (2) 1/32" x 1-5/8" darkened brass rods as **Sheer Poles** on the orange line above the **Deadeyes**. Rig the Ratlines starting with every fifth one and then fill in between as seen in the picture below. Next cut and darken two (2) 1/32" x 1/2" brass rods that are the **Futtock Staves** to be seized at the top of the **Ratlines** aligned with the bottoms of the **Cheeks**. Using (1210) **Black** line tie the two (2) **Catharpins** by seizing the lines to one end of the **Futtock Staves** then around the **Topmast** below the **Cheeks** and back to the other ends of the **Futtock Staves** and seize in place. See the picture below.

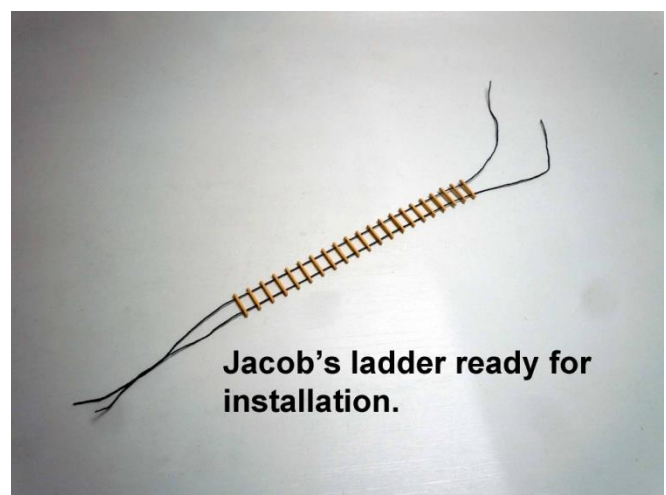
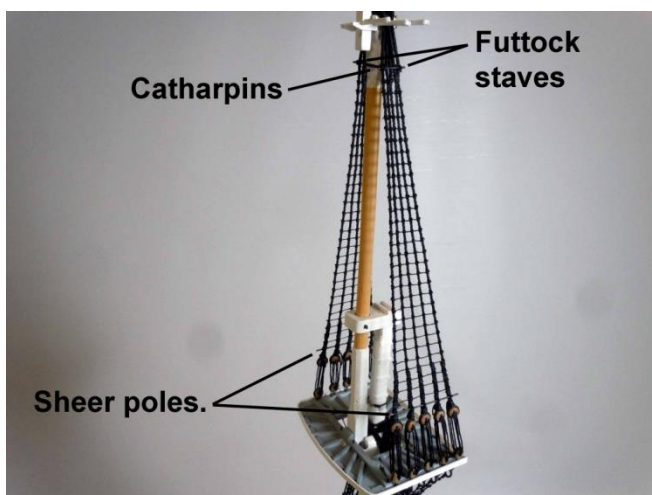
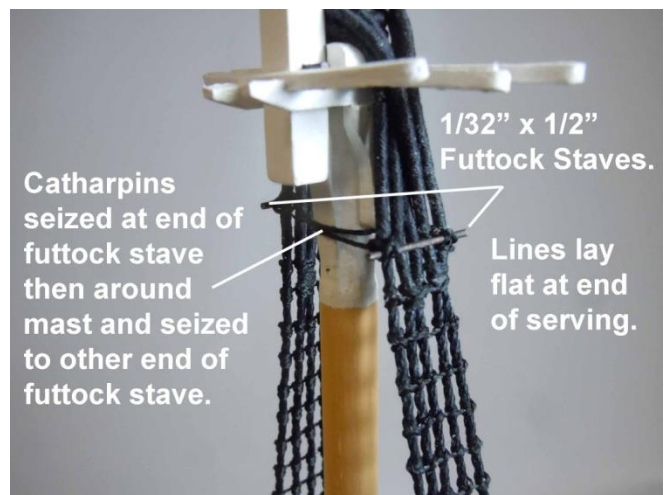
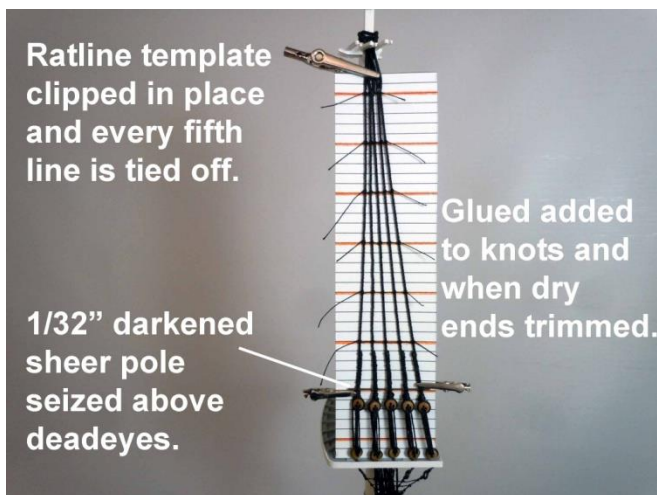

Jacob's Ladder: The **Jacob's Ladder** is a rope ladder from the **Topmast Crosstrees** up to the

Topgallant Crosstrees. The twenty one (21) **Ladder Rungs** are laser cut using 1/32" thick sheet with extra parts. Remove and clean off excess char and ream holes with a 1/32" drill bit if necessary.

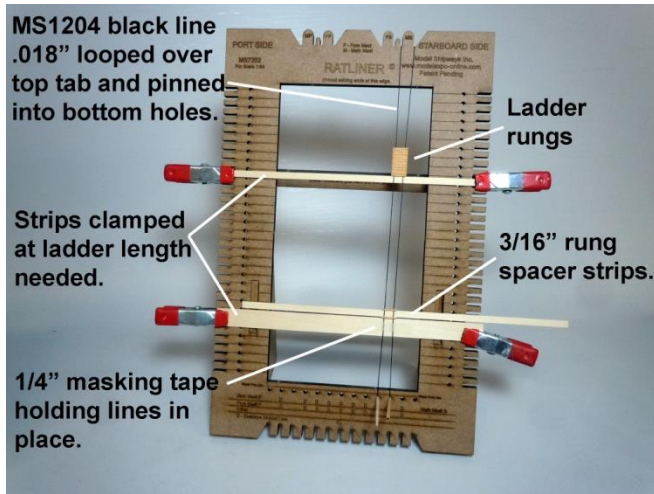

Next a fixture can be made or use a **Ratliner** to assemble the **Jacob's Ladder**. Cut a length of (1210) **Black** line and form a loop and add the **Rungs** to the rope as seen on the **Ratliner** in the picture above. Using 3/16" and 1/2" wood strips establish the length of the rope needed by measuring the distance between the **Crosstrees** and clamp strips in place. Starting at the bottom add and glue the first **Rung** and let the glue set before adding the rest of the **Rungs** using the 3/16" spacer strips of wood. Check to make sure all the **Rungs** are glued tightly to the ropes before removing from the build fixture. Insert four (4) **Jackstays** as eyebolts for the **Ladder** ropes vertically into the holes at the ends of the **Trestles** and glue in place. Insert the top ends of the **Ladder** ropes through the eyebolts and tie off with the top **Rung** 3/16" below the **Crosstree**. Insert the lower ropes through the lower **Eyebolts** and weight down the ends with a small spring clamps and glue the upper knots with glue and allow to set. Tie off the lower ropes to the eyebolts and add glue to the knots and allow to set. See pictures above and below..

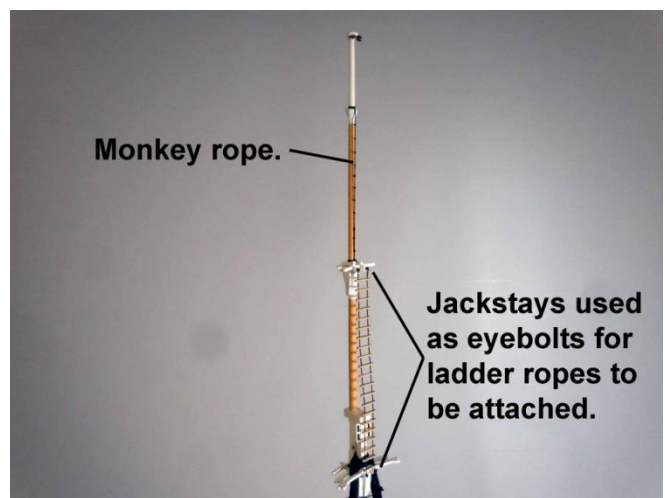
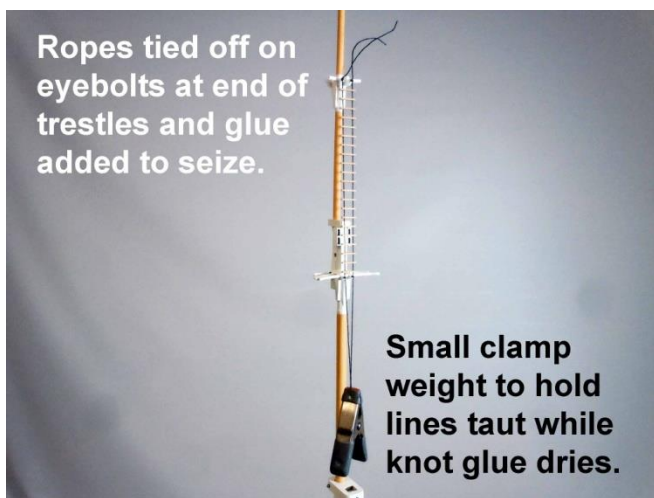

Fighting Top Guard Rail: Now that the **Mast** is stepped the **Fighting Top Guard Rail** can be added. **Delicate Parts!** The **Guard Rail** parts are laser cut 1/32" sheet parts that great care must be taken when working with them. The two (2) **Guard Rail Frames** will sandwich the **Netting** between them

when glued together. First remove the two (2) **Guard Rail Frames** from the carrier sheet and add a drop of CA glue at the joints of the rails and pickets to strengthen them to minimize breakage and allow CA to set. Note that there are locating pins on the rear **Frame** and none on the forward **Frame**. Very carefully sand any excess char and carrier sheet tabs smooth. Paint the **Frames** and **Baseboard** with locating holes White and take care not to fill the holes with paint. Apply a coat of White glue to the surface of the **Forward Frame** and with the **Netting** laying on a piece of wax paper position the glue side down on the **Netting** and weigh down for flatness. Allow the glue to set. Remove from wax paper and carefully with a sharp hobby knife cut the **Netting** along the bottom edge of the **Guard Rail Frame**; then cut along the top edge. Carefully cut the **Netting** away from both ends. Now glue the **Rear Frame** making sure to index and match the rails and pickets to the **Forward Frame** sandwiching the **Netting** between them. Once glue has set carefully sand all the edges and touch up with paint. Now index and glue the locating pins into the **Baseboard** with the angled ends facing forward. Add the small reinforcing **Blocks** to the upper rail and then the large **Blocks** to the lower rail resting on the **Baseboard**. The end **Blocks** at the angle cut of the **Baseboard** must be trimmed to match location so test fit and adjust as needed. Finally, sand the bottom surface of the **Baseboard** and glue the assembled **Guard Rail** to the **Fighting Top**. See the pictures below.

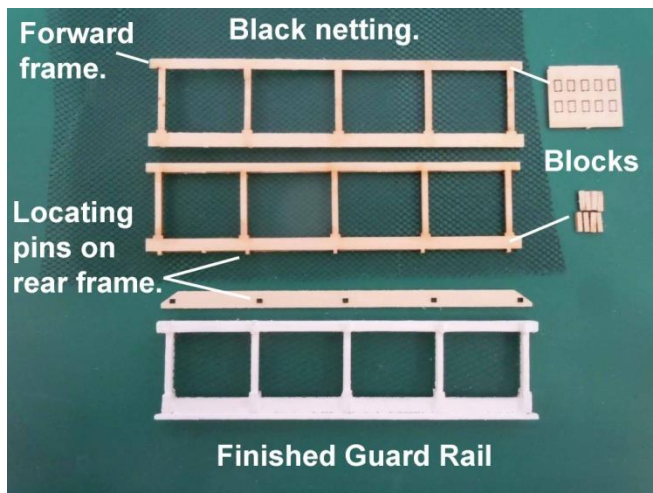

Rigging Topgallant and Royal Shrouds: Using (1210) **Black** line cut six (6) lengths 16" long and these will be the **Topgallant Shroud** lines; then cut four (4) 20" lengths and these will be the **Royal Shroud** lines. Seize small **Hooks** to one end of each of the ten (10) lines using double seizing and harden the other ends with CA to form a needle end. See picture on the next page. Starting on the **Starboard** side and using a 20" length and starting at the **stern end** insert the line between the last two **Shrouds** at the **Stave** below the **Crosstree** and then index the **Hook** end onto the last **Eyebolt** next to the **Guard Rail** and pull the snug enough to hold the **Hook** in place. Next engage the line onto the notch in the **Crosstree Arm** and seize to the mast with a clove hitch at the top **Royal Mast Stop**. This is the **Royal Shroud**. Repeat for the port side **Royal Shroud**. Next add the next two (2) 20" **Royal Shrouds** engage the **Hooks** on the **Center Eyebolts** and inserted through the **Center** of the **Shrouds** at the **Staves**; indexed on the **Crosstree Arm** notches and seized with **Clove Hitches** above the first hitches at the **Royal Mast Stop**. The four (4) **Royal Shrouds** should be in place. Now to add the six (6) 16" **Topgallant Shrouds**, similar to the **Royal Shrouds** will be hooked at the remaining **Eyebolts** inserted through the **Shrouds** in sequence: end; center and end, with the **Stern End** and **Center** being

shared with the **Royal Shrouds** but being seized with clove hitches at the **Topgallant Crosstree**. See pictures below.

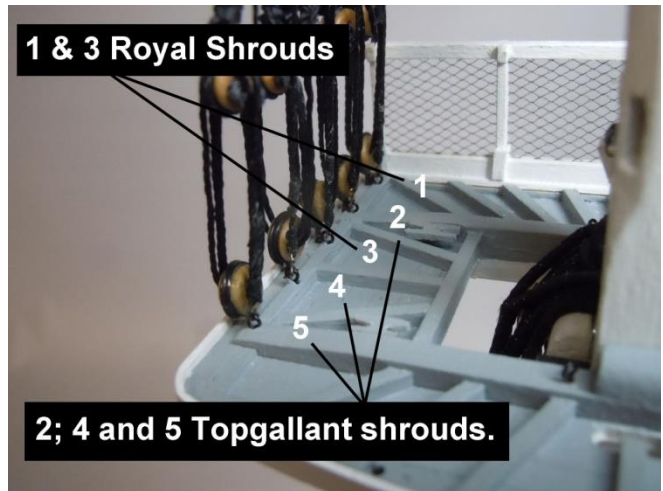
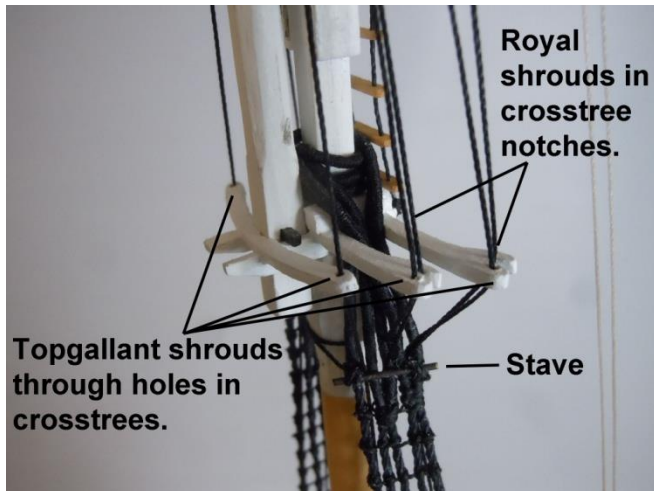
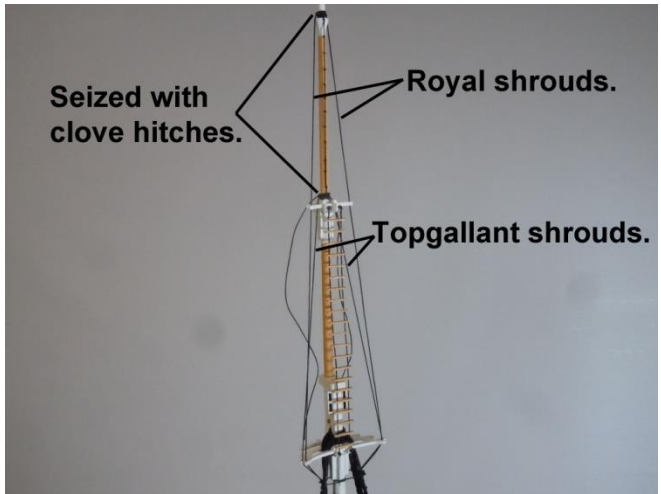
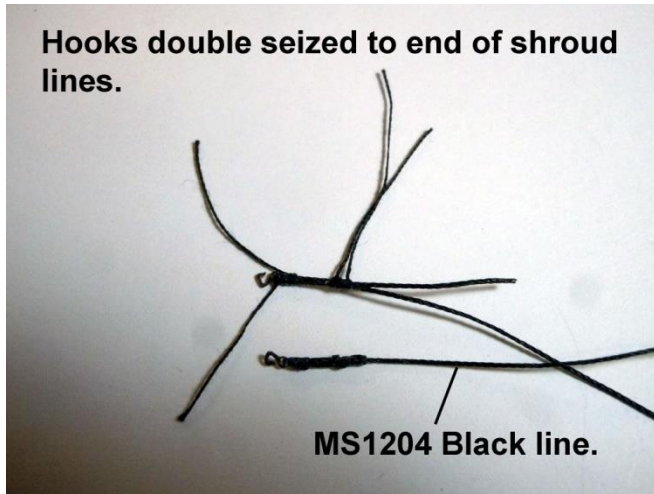

BUILDING YARDS:

Main Lower and Topsail Yards: These two (2) **Yards** are of similar construction and can be built together with the main difference being the configuration of the **Cleats**.

Cut 5/16" square wood to a length of 3-1/2". Drill 5/32" holes to a depth of 1/2" on center of each end. Then cut it into a hexagon using pencil guidelines on wood. Mark 5/16" dowel at 6-1/16" long on two sections and cut taper 1" from 5/16" end down to 1/8" at opposite end. Taper can be cut and formed by hand or on a lathe using an angle cut of 1-1/2 degrees from small end. Once satisfied with smooth taper then mark 3/8" back from 6 -1/16" and carefully cut a 3/8" long and 5/32" diameter indexing round peg to fit into the hexagon end holes. **A slip fit is better than a tight fit to allow for glue and air to escape when gluing tapered yards in place.** Glue tapered yard sections in place using yellow glue added to indexing pegs. See pictures on the next page.

Repeat above steps for **Top sail Yard**. Then taper the one piece **Topgallant** and **Royal Yards**. By having all **Yards** assembled and tapered they can go through the following build sequences at the same time.

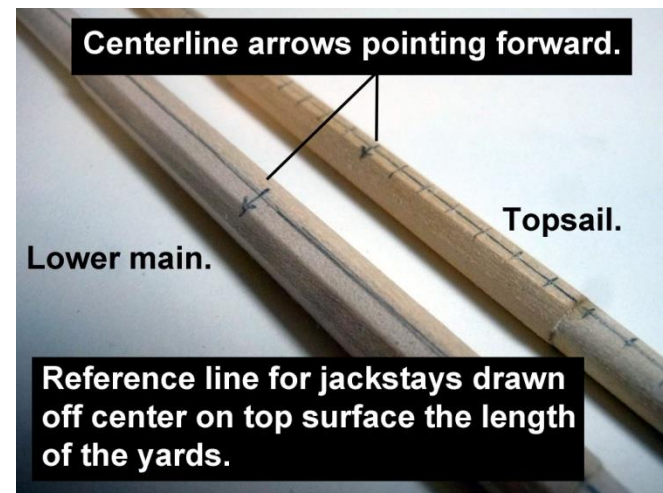
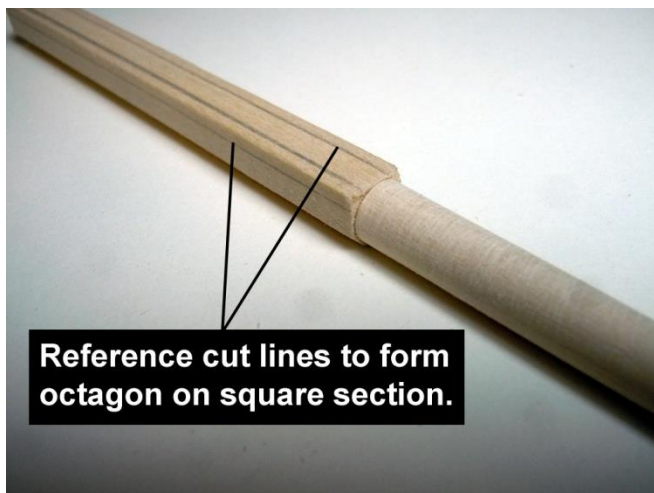
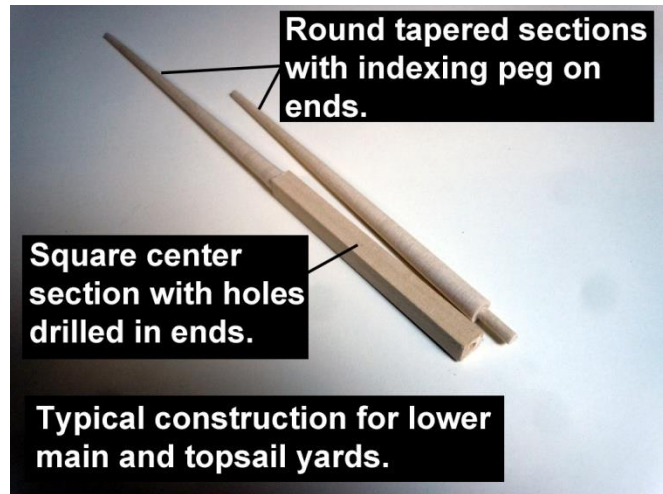
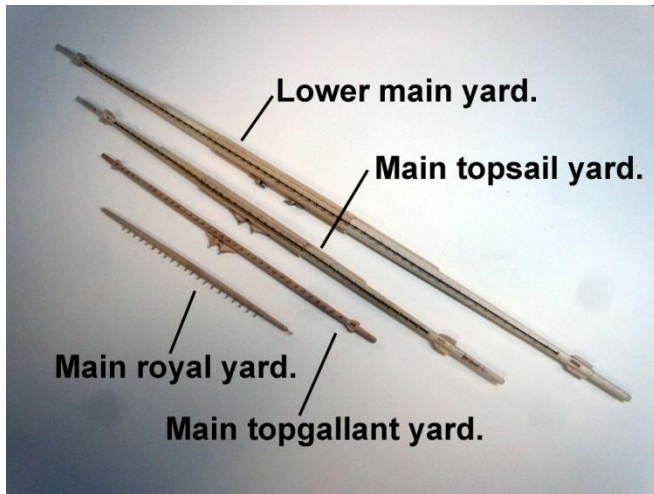

Mark a reference line slightly off center to the rear of the top surface for **Jackstay** locations that are spaced $3/16$ " apart on the **Main Yard** and **Topsail Yard**. Mark the reference line on center for the **Topgallant** and **Royal Yards** and $5/32$ " apart on the top starting at centerline of the **Yards**. Next mark the **Jackstay** locations on the reference line using small dividers for even spacing. Now mark pencil lines perpendicular to reference line on the hole locations. Setup the **Yards** in a vise on an X-Y table and drill **Jackstay MS0429B** locations using a #74 drill bit trying not to drill completely through the **Yards**. **Note** that the ends of the **Yards** will have to be braced or supported to compensate for deflection and avoid breaking drill bits. Drill all **Yards** at the same time. See pictures above and on the next page.

Mark, drill and cut the **Reef Tackle Sheave** locations using a $3/64$ " drill bit on the **Main Lower Yard**, **Topsail** and **Topgallant** yards. (Not the **Royal Yard**) Next cross drill the axle pin (8mm nails) locations on the center of the sheave hole locations using a $1/32$ " drill bit. Next using the $1/32$ " drill bit; drill the outboard ends of all the **Yards** including the **Royal** to a depth of $3/8$ ".

Locate and remove from the carrier sheet the three (3) laser cut **Tye Cleats** for the **Topsail**; **Top Gallant Yard** and **Royal Yards** and glue to the rear side on center of the **Yards**. The larger one is for the **Topsail Yard**. Use the #76 drill bit and drill holes on the upper flat surfaces of the **Tye Cleats**; two per **Cleat** on either side of the half round cut. Insert and glue trimmed **Jackstays MS0249B** into the holes with the loop parallel with the length of the **Yard** and touching the wood surface. Then remove the laser cut **Sling Cleats** and glue in place to the backside of the **Main Lower Yard**. For ease of installation of the **Yards** to the Mast drill on center of the **Yards** between the **Cleats** a 1/32" brass locating pin. See picture below.

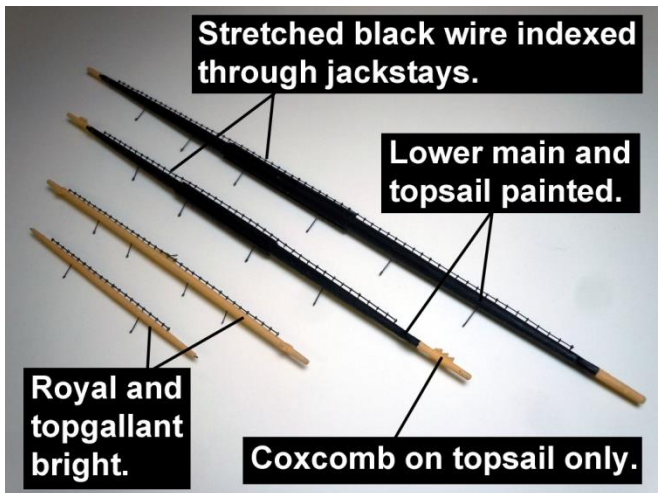
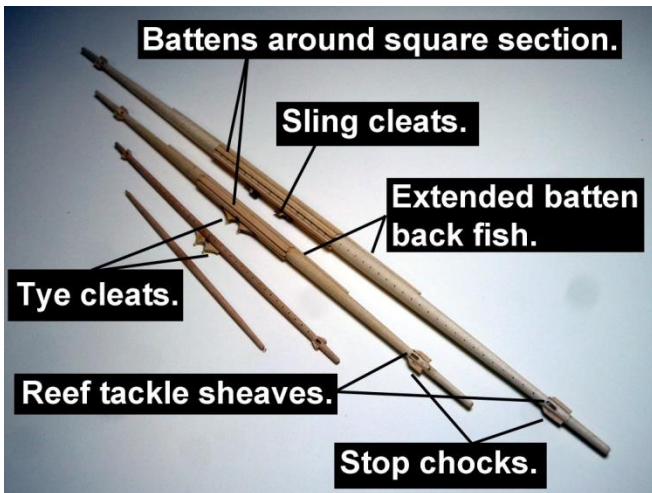
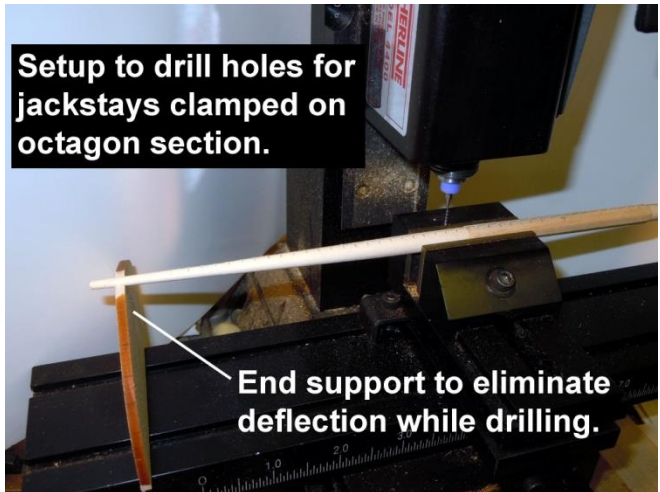
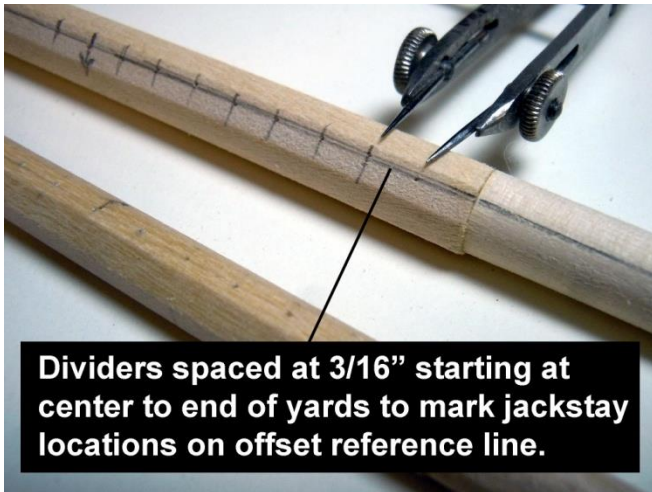

Next add the **Stirrups** to the bottom of all the **Yards** using full length **Jackstays, MS0428 5mm** using the plans for the spacing of each **Yard**. Next add the **Stop Chocks** with the inboard ends aligning with the **Sheave** holes, check the plans; then add the **Coxcombs** (2) to the **Topsail Yard** only on the top surface 3/8" from the ends of the **Yard**.

Drill 1/32" holes in the **front surface** of the three following **Yards** in from the ends of the **Yards**. **Main Lower Yard: 2-5/8"**; **Topsail Yard: 1-7/8"**; **Topgallant Yard: 1"**; these holes will hold the guides for the **Studding Sail Booms**.

Using **26 gauge Black Wire** lengths cut the length of the four (4) **Yards** hold one end of the **Wire** in a vise or hold with pliers and with the other end held in pliers pull and stretch the **Wire** enough to straighten. Cut one end and then carefully insert the end through the **Jackstays** on top of the **Yard**. Glue each end and center **Jackstays** and **Wire** with a touch of CA. Once the CA has set, carefully trim each end of the excess **Wire** on the outboard side of the end **Jackstays**. Repeat for each **Yard** as seen in the picture above.

Now paint the **Main Lower Yard** and the **Topsail Yard** Hull Spar Black from the outboard ends of the **Stop Chocks** leaving the ends stained Natural as seen in the picture above or on the next page.

Using 2 or 3 foot lengths of **(1210) Black Line** soaked with 50/50 glue suspend with a clamp weight on one end allow the glue to set. Then using cut lengths for each **Yard** index the line through the **Jackstay** loops and seize one end with a clove hitch butted against the **Stop Chocks** then form slight curves between the **Stirrup Jackstays** and seize the end with a clove hitch at each **Yard** location as seen on the plans and the picture below. **DO NOT** glue the lines to the **Stirrup** intersections yet, this can be done once all the **Yards** are rigged in place and for final touch up.

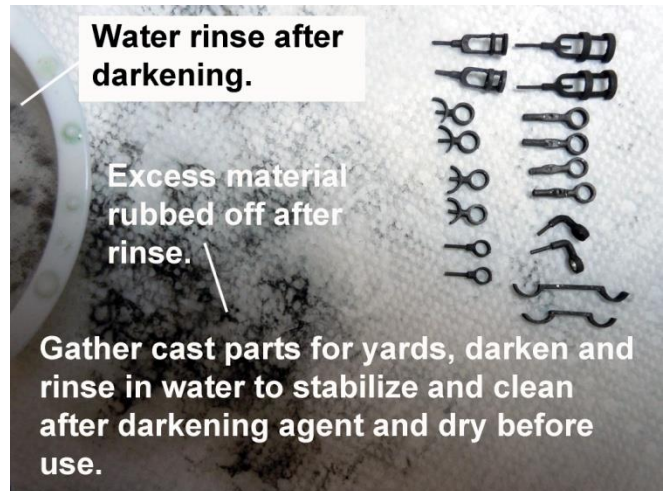
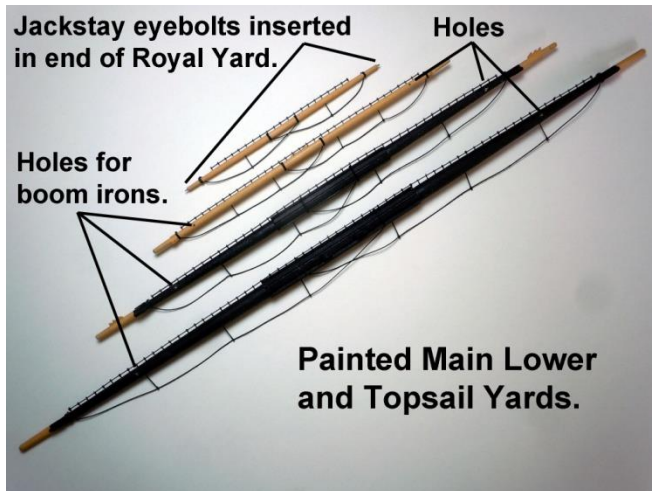

Ironwork: Locate the eighteen (18) cast metal parts for the **Yards** as seen in the picture above. Clean, adjust and darken all the parts; keep in mind if using a darkening agent to rinse in water to stabilize the process. Clean the parts very gently on a damp paper towel removing any excess agent and allow drying completely. **Note** that the lower right half rings will be cut from the carrier strip needed for casting.

Make the six (6) **Studding Sail Booms** for the three (3) lower **Yards**; **Topgallant**, **Topsail** and **Lower**. See picture on next page and plans for dimensions. The key point to remember is that the finished diameter of the **Studding Sail Booms** must slip through the **Yard Rings**. .020" holes are drilled in each end to receive the darkened **Jackstays**. **Jackstay Eyebolts** MS0428 can be darkened; glued and trimmed to the **outboard** ends of the **Booms** only for now. These **Booms** are needed to align the **Boom Hardware** to be added to the following **Yard** builds. Set them aside for now until they are needed to align **Studding Booms Hardware**.

Start with the **Topgallant Yard** and insert and glue the two (2) **Boom Rings** with posts into the previously drilled holes making sure the **Boom Rings** are positioned equally respective to each other

and allow the glue to completely set. Now with the two (2) **Studding Sail Booms** for the **Topgallant** and the two (2) **End Guide Rings** with the bent shafts; insert the **End Ring Shafts** locating pins into the holes drilled into the end of the **Booms**. Index the **Booms** into the **Rings** and align them horizontally with the **Yard** and glue the locating pins into the ends of the **Yard** and let the glue set completely. See the picture below. Now the two inboard **Jackstays** can be glued into the holes on the inboard ends of the **Boom**.

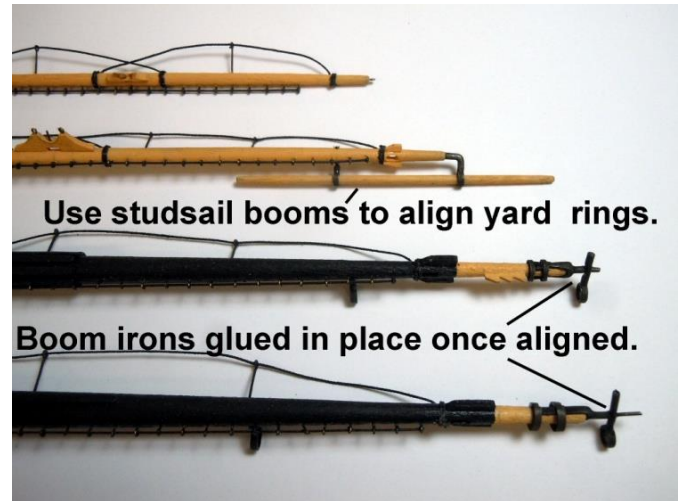
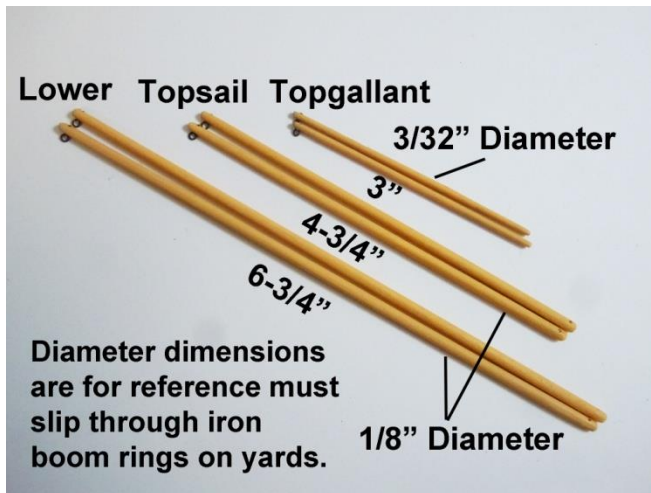

Topsail and Lower Yards: Add the four (4) inboard **Guide Rings** with short locating pins; note that the smaller sizes of **Ironwork Guides** go with the **Topsail Yard**. Once the glue has set on the inboard guides add the **End Guides** with the horizontal bands centered on the **Yards** fore and aft. The **Lower Yard End Guides** have locating pins to be inserted into the holes drilled into the ends of the **Yard**; note that the **Lower Yard** will need the **Half Round Rings** to complete them and add them once the glue has set on the **End Guides** as seen in the picture below. Now using the **Studding Sail Booms** for each **Yard** and the four (4) **End Guide Rings** index the **Rings** on the end shafts and use the **Booms** to align the **End Guides** so the **Booms** are horizontally aligned with the **Yards** and then glue the **End Guide Rings** in place on the shafts as seen in the picture above. Once the CA glue has completely set carefully cut off the ends of the shafts flush with the **Ring Guides** as seen in the picture below (**Booms** not shown for clarity). All **Yards** should now have all **Ironwork** in place and ready for rigging.

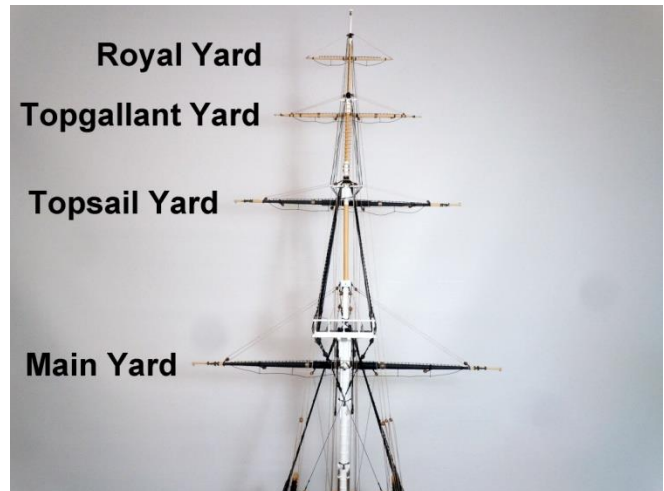

RIGGING THE YARDS: Builders have different approaches to rigging **Yards** and **Masts**; however they all require a great deal of patience and planning ahead. Studying the instructions and plans are best before starting. A decision by the builder must be made as to whether rig the **Yards** in the **Sail** position or the **Rest** position or a combination of both. The plans show the **Yards** in the **Sail** position with the **Rest** position ghosted in; this decision will dictate where location holes in the **Mast** will be drilled. The approach for this build will be from the top down; reason being that it is much easier to rig the longer running lines from the **Royal Yard** without the lower **Yards** being in the way. Also the **Royal Yard** is the simplest to start, with the least amount of rigging.

Royal Yard: Seize a short length of Beige Rope (1242) to one side of the **Tye Cleat Eyebolt** and touch a drop of 50/50 glue mix to the knot and when dry trim off excess line. Then at the base of the **Tye Cleat** opening seize a length of rope the height of the mast top to the ship base with a clove hitch between the **Jackstay**, the **Locating pin**. See picture on the next page. Now strop three (3) **Single 4mm Blocks**; two (2) facing outboard on the sides with the third facing forward on the **Mast** just above the **Black Shroud Lines**. Next seize two (2) (1242) **Beige Lines** the length from the end of the **Royal Yard** to the blocks on the **Mast** and down to the **Fife Rail** on the **Spar Deck** with enough excess to tie off on **Belaying Pins** on the **Eyebolts** at the ends of the **Yard**. These Lines are the **Royal Lift Lines**. See picture below. Index the two (2) **Royal Lift** lines through the **Single** side **Blocks** and the **Royal Halliard Line** through the forward facing **Single Block**. First seize the two (2) **Royal Lift** lines to their respective **Belaying Pins** on the **Fife Rail** (see Plan Sheet 2) and equalize the lines so that the **Royal Yard** is perpendicular to the **Mast**. Once equalized add a drop of glue mix to the seizing at the **Belaying Pin** to hold the lines secure from loosening. See picture on next page.

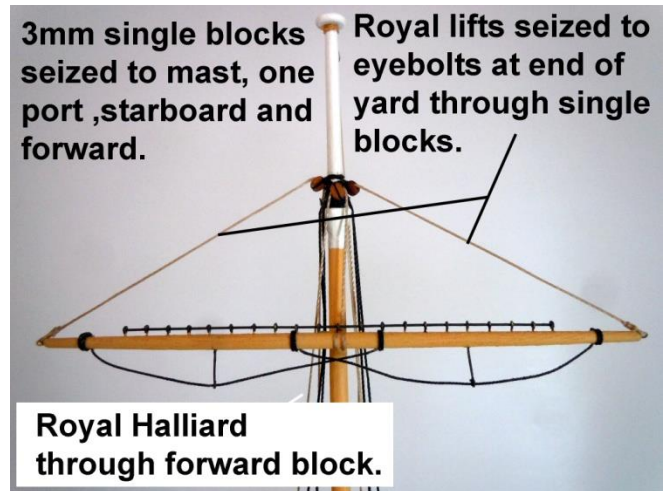

Strop at the end of the **Royal Halliard**, at the height of the pendants a **4mm Double Block**. See picture on the next page. Make three (3) **Eyebolts**, insert and glue them into three (3) holes drilled into the stern end of the starboard **Channel**. Cut a length of **(1242) Beige** line five (5) times the length between the **Royal Halliard Double Block** and the **Eyebolts** on the **Channel**. Seize one end of the line to a small **Hook** then a **Double Block** and finally double seize the line to itself. See the picture below. This line is the **Jig Tackle**.

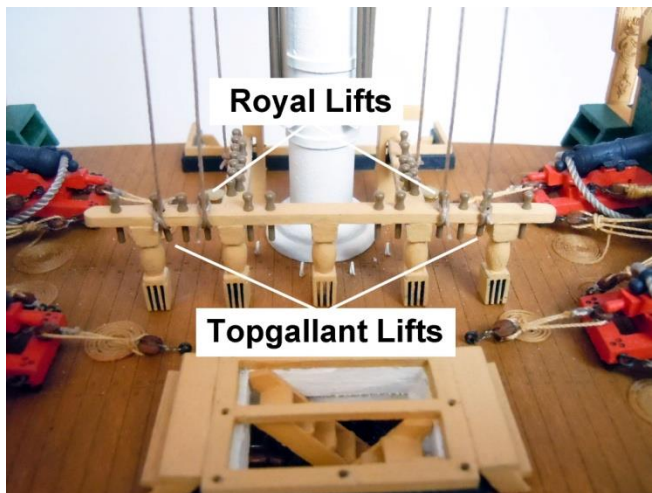

Drill three (3) $\frac{1}{32}$ " holes a $\frac{1}{4}$ " deep with the first centered and then one on either side at $\frac{5}{32}$ " into the end surface of the starboard **Channel**; then make and glue into the holes three (3) **Eyebolts** made using black wire with a $\frac{1}{4}$ " stem for strength. Now engage the **Jig Tackle Hook** into the outboard **Eyebolt** in the **Channel** and insert the end of the **Jig Tackle** through one hole in the **Double Block** seized on the end of the **Royal Haliard** and then down through the hole in the **Single Block** above the **Hook** and back up through the second hole in the **Double Block** and finally back down and seize to the last **Belaying Pin** in the **Starboard Pin Rail**. See picture on the next page.

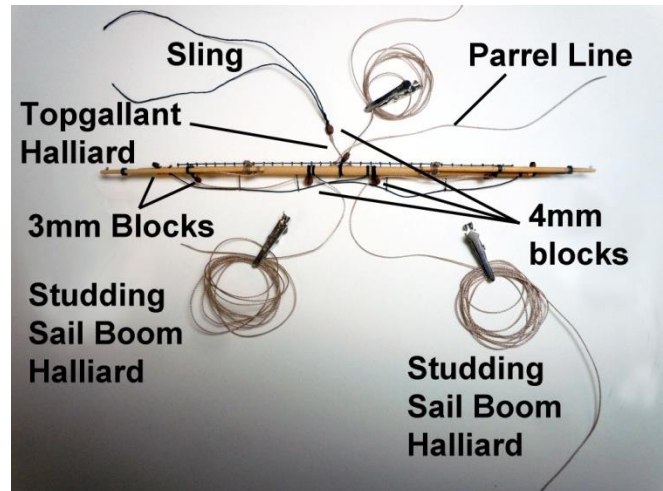
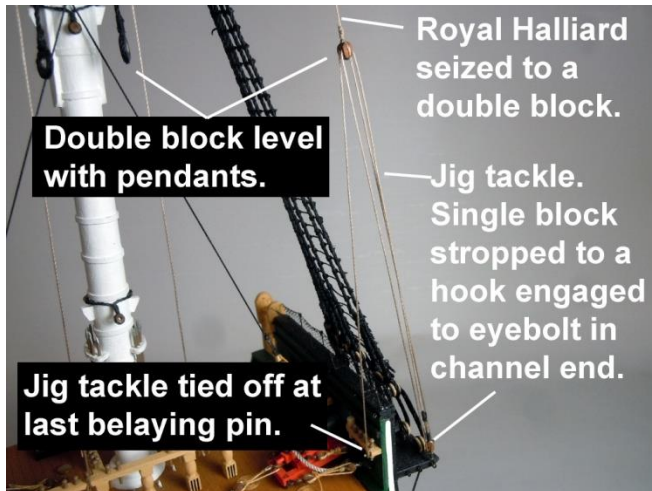

Topgallant Yard: The **Topgallant Yard** requires additional **Blocks** and five (5) long **Lines** best rigged prior to positioning the **Yard** on the **Mast** as seen in the picture above (two (2) **Lift Lines** not shown). Prepare the five (5) long lines using **(1242) Beige** line cut to 36" lengths completely wetted with water; pulled through fingers and hung weighted down with small clamps to dry. This process takes out the kinks, reduces the sizing used in producing the line and relaxes the twist for a straighter line to rig. Remember it is better to have a line too long than one too short. Cut offs can be saved and used to make **Coils** later. First seize four (4) **3mm Blocks** to the ends of the **Yard** against the chocks facing up and two (2) 5/8" inboard of the chocks facing down; then seize a **4mm Block** at the center of the **Yard** around the locating pin facing up using **Black Line (1210)**. Seize two (2) **4mm Blocks** 5/8" on either side of the center facing down. Now make the **Sling** by stropping a **4mm Block** to a 4" length of **Black Line (1210)** and seize one end of a long **(1242) Beige** line to the **Block** and the line indexed through the **4mm Block** on the center of the **Yard**. Use a 3" length of Beige line seized to one side of the **Tye Cleat Eyebolts** as the **Topgallant Parrel**. Once all the **Blocks** are in place on the **Yard** insert the **Studding Sail Booms** in their irons and glue in place the **Eyebolts** to the inboard ends of the **Booms**. Position the **Studding Sail Boom Eyebolts** facing up and the outboard ends 3/8" from the ends **Iron Rings** now lash the **Booms** to the **Yard** using **(1242) Beige** Line. Seize two (2) small **Hooks** to the ends of two (2) lengths of the long Beige lines. Engage the **Hooks** on the inboard **Eyebolts** on the **Studding Sail Booms** then index the lines through the **3mm Blocks** facing down then back to the **4mm Blocks** facing down. The rigged **Yard** is ready to position on the **Yard**. See the picture on the previous page. Apply a drop of Medium CA to the end of the locating pin and set the pin into the hole on the **Mast** for the **Topgallant** position the **Yard** square to the **Hull** and **Mast** and allow the CA glue to set. Seize the other end of the **Parrel Line** to the **Eyebolt** on the **Tye Cleat** around the **Mast**; apply glue to the knot, let set and trim off excess line. Seize the **Sling** to the **Mast** just above the **Shroud Lines** and add 50/50 glue mix to the knot, let set and trim off excess line. Now carefully feed the end of the long line, **Topgallant Hailyard** down the starboard side of the **Mast** outside the **Cross Trees** and **Fighting Top** and strop a **4mm Block** the height of the **Pendants**. Now rig the **Jig Tackle** just like what was done for the **Royal Hailyard** and engage the stropped **Hook** on the second **Eyebolt** on the **Channel** and seize at the second **Belaying Pin** on the **Starboard Pin Rail** next to the **Royal Hailyard**.

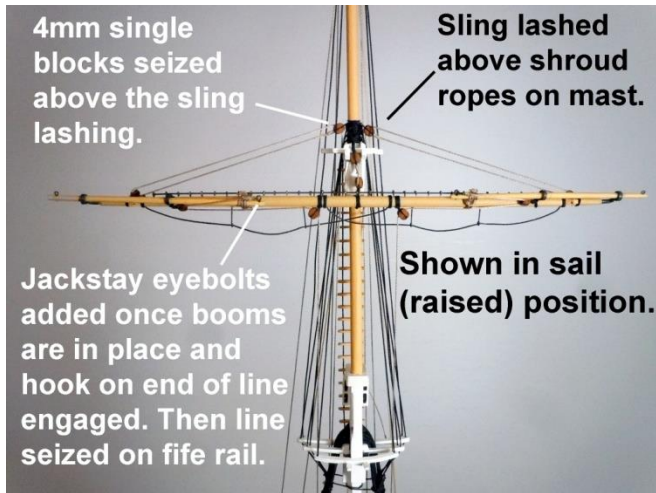

Strop and seize to the ends of two (2) long (1242) Beige lines to **4mm Blocks** these lines are the **Topgallant Lift Lines** the blocks are then seized to the **Mast** above the **Sling** facing port and starboard; apply 50/50 glue mix, let set and trim excess line. Index the ends of the **Lift Lines** through the **3mm Blocks** at the chocks then back up to the **4mm Blocks** and then down to the aft **Fife Rail Belaying Pins** and seize as seen in the picture on the previous page. Use the lines if necessary to adjust the squariness of the **Topgallant Yard** to the **Mast**. Carefully feed the **Studding Sail Boom Halliyard** lines down through the **Crosstrees** and **Fighting Top** to the forward section of the **Fife Rail** and seize the lines port and starboard to the third **Belaying Pins** from the bow end of the **Fife Rail**; glue and trim the excess line when the glue mix has set. Reglue the **Yard** to the **Mast** at the locating pin if necessary.

Topsail Yard: Many of the same steps will be used rigging the **Topsail Yard** as used on the **Topgallant**; however please note the size changes used for the **Blocks**. The **Topgallant Yard** requires six (6) 36" long (1242) **Beige Lines**; of which two are best rigged prior to positioning the **Yard** on the **Mast** as done on the **Topgallant Yard**. These lines are the port and starboard **Studding Boom Halliyard** lines. The four (4) **Topsail Lift (2)** and **Halliyard (2)** lines are added once the **Yard** is in place on the **Mast**.

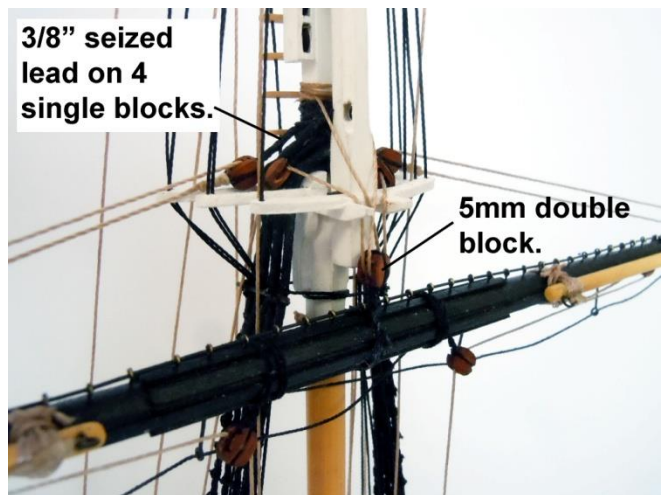
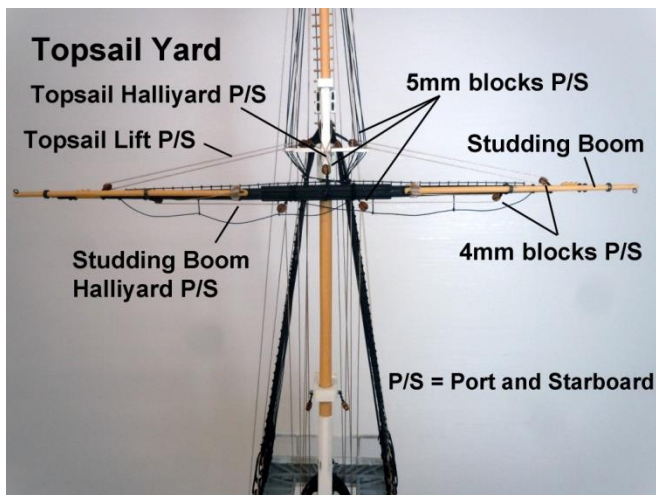

First add the four (4) **4mm Single Blocks** to the ends of the **Yard**; 2 seized against the **Stop Chocks**

facing up and two (2) just inside against the inboard iron **Boom Guide Ring** facing down as seen in the pictures above. Next add two (2) **5mm Single Blocks** with 1/4" seized lead 3/4" from the center of the **Yard** facing down. Now add a **5mm Double Block** on center of the **Yard** with a 1/4" seized lead facing up. Add a six (6) inch long **Parrel** line tied to one of the **Eyebolts** in the **Tye Cleat** on the backside of the **Yard**. Now index the two (2) **Studding Booms** into the **Guide Rings** and glue the inboard **Eyebolts** in place. Now lash the **Booms** to the **Yard**. Seize two (2) 36" lines to the inboard **Eyebolts** on the **Booms** and insert the end of the through the lower **4mm Blocks** and coil up the length.

Strop four (4) **Single Blocks** with 3/8" seized leads; but two (2) must have two (2) 36" lines seized to the **Blocks** first. Take the other two (2) **Single Blocks** and seize them to the **Mast** just above the **Shroud** lines facing forward. The **Yard** locating pin can now be indexed and glued into the location hole drilled in the **Mast** (either in the up or stowed position). The picture above shows it in the up position. Then tie the **Parrel** line around the **Mast** to the other **Eyebolt** on the **Tye Cleat**. Next rig the two coiled **Boom Halliyard** lines through the lower inboard **5mm Single Blocks** and then down to the forward section of the **Fife Rail** and seize at the second **Belaying Pin**. Adjust the line tension to make sure the **Yard** is level to ground and square to the **Mast**; once satisfied apply white glue 50/50 mix to knot at **Belaying Pin**. Trim excess line when dry and save cut off line.

Seize the two (2) **Topsail Halliyard** lines with the **Single Blocks** on the **Mast** just above the previously attached **Single Blocks** above the **Shroud Lines**. Carefully insert the end of the lines through the bottom side of the **4mm Single Blocks** facing upward on the outboard end of the **Yard**; then back through the upper side of the **Single Blocks** and down to the aft section of the **Fife Rail** and seize to the inboard **Belaying Pins** adjusting the line tension as needed then apply glue mix to knots at the pins. Trim excess line when dry and save cut off line. See picture on the next page.

Seize the two (2) **Topsail Halliyard** lines using clove hitches to the **Mast** above the previously seized lines above the **Shroud** lines with the **Halliyard** lines coming around the **Mast** on the port and starboard sides of the **Mast**. See picture above. Insert the ends of the lines through the bottom hole in the **Double Block** and then through the top hole of the forward **Single Blocks** and carefully fed down through the **Crosstrees**. Strop a **Double Block** to the **Halliyard** line at the height of the **Pendants** like previously done **Jig Tackle**. Seize small **Hooks** to the ends a lengths of line and then **5mm Blocks** just after the **Hooks** as previously done. Drill .020" hole in the end of the port **Channel** 5/32" from the **Hull** and glue an **Eyebolt** in place. Now rig the **Jig Tackles** with the port and starboard sides engaging the small **Hooks** onto the **Eyebolts** insert the end of the line through one of the upper holes in the **Blocks** then back down to the **Single Blocks** and back up to the **Double Blocks** a down and seize to the third **Belaying Pin** on the starboard side **Pin Rail** and the second **Belaying Pin** on the port side **Pin Rail**. Adjust the line position and tension and needed and apply glue mix to knot at **Belaying Pins**. Trim excess line when dry and save cut off line.

Studding boom inserted through iron rings then inboard end eyebolt added. Lashed to yard and line seized to eyebolt.

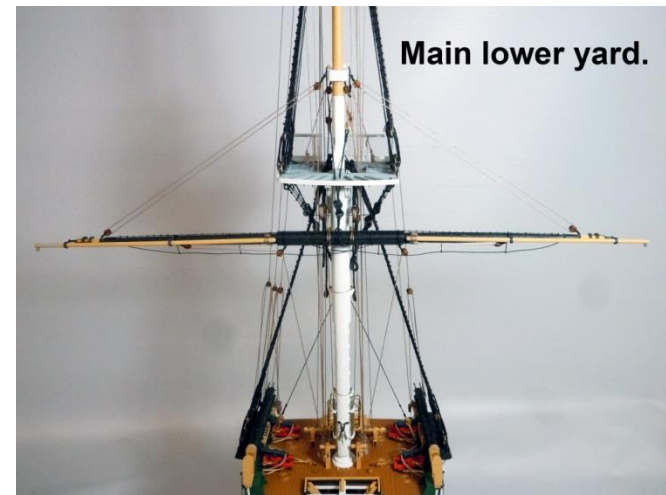
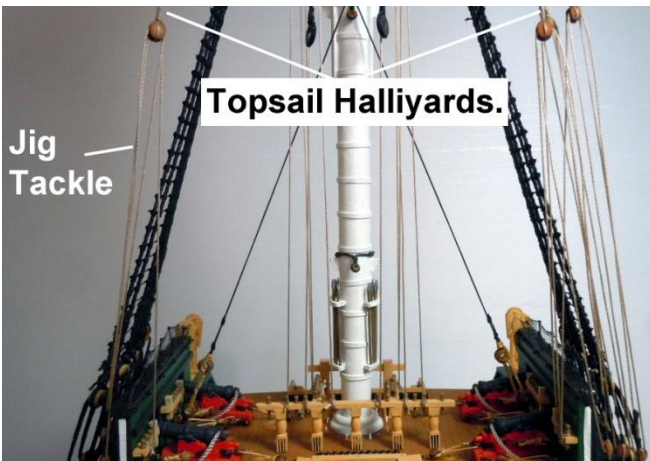
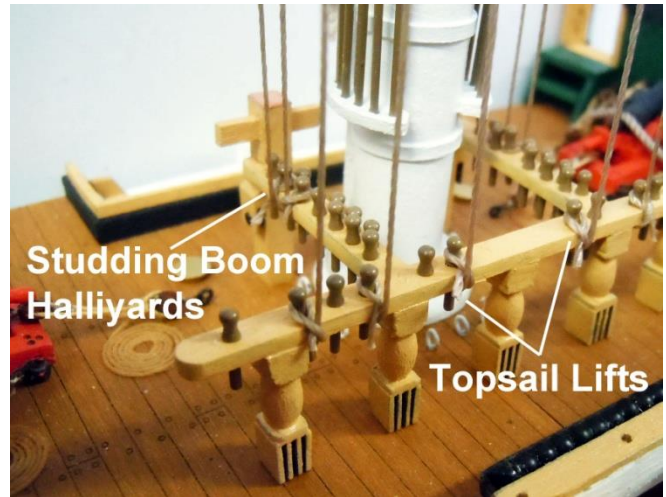
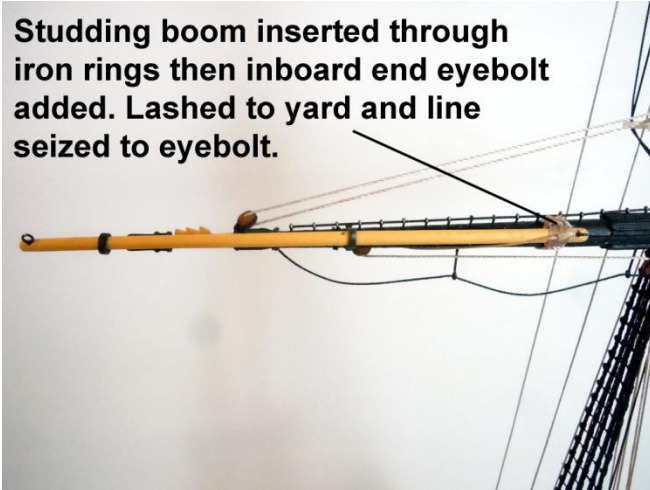

Main Lower Yard: The rigging for the **Main Lower Yard** seen above will be a little more complicated than the previously rigged **Yards**. Like the previous **Yards**, blocks will be added in similar locations and sizes as noted in the picture on the next page. Strop four (4) **Single 5mm Blocks** and two (2) double **Blocks** with 3/16" leads. Secure the two (2) **Double Blocks** port and starboard 1-3/4" from the center of the **Yard** just before the ends of the **Battens**. Next secure the four (4) **Single Blocks** port and starboard to the **Yard**, two just inboard of the **Ring Iron** below the **Yard**, the second two (2) at the end of the **Chocks** on the upper side of the **Yard** as seen on the next page. Then strop two (2) **Triple Blocks** with (1210) line with 1/4" leads and secure to the **Yard** port and starboard inside the **Sling Cleats** on the front side of the **Yard** with the leads on the backside of the **Jackstays** as seen in the pictures below.

Slings: There are two (2) **Sling** sizes using (1210) **Black** line and both will be seized to **Cast Rings**. The **Short Sling** will form a loop seized to a **Cast Ring** just long to wrap around the center of the **Yard** feeding the **Cast Ring** through the loop on the back side of the **Jackstays**. The **Long Sling** will have a **Cast Ring** seized with a short side and a longer side with each length having a small loop seized on the ends. The length is determined by the distance from the **Yard** position with the long side up through the opening in the **Fighting Top** and around indexing into the rear of the **Mast Cap** and back down. The short side will go up through the opening in the **Fighting Top** and end 1 inch from the end of the

long side. Then tie about a six (6) inch length of **(1242) Beige** line to the small loop at the end of the long side of the **Sling**. See the pictures and below. Then lash the two **Cast Rings** of the **Slings** together with **(1210) Black** line.

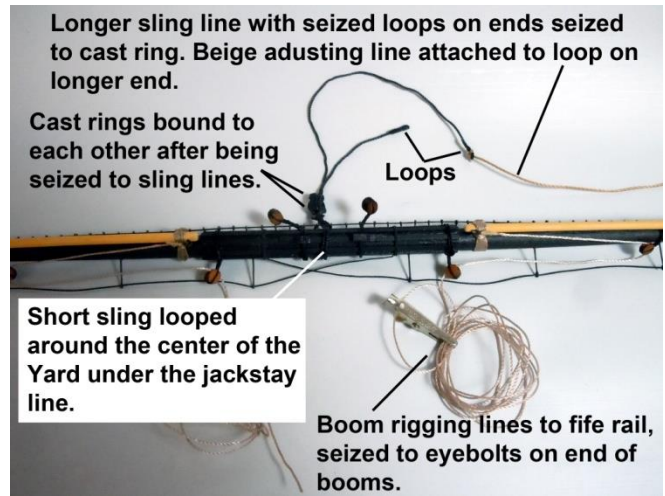
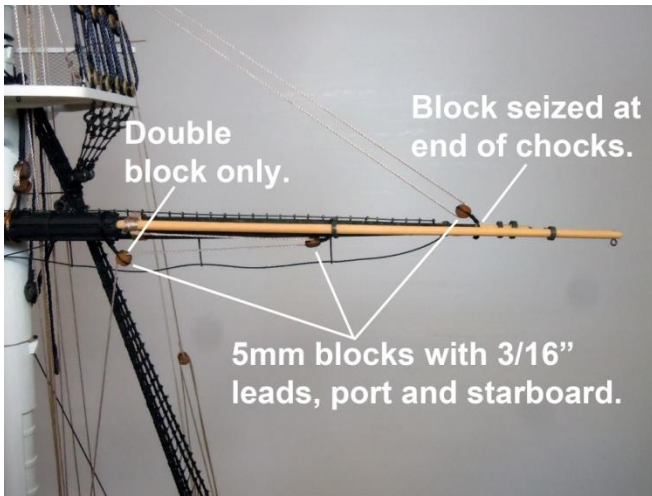

Booms: Insert and lash the two (2) **Booms** in place through the **Iron Rings** to the **Yard** and secure the lashing with a square knot as seen in the picture below. Note that the **Eyebolts** on the **Booms** will face down. Seize a small **Hook** to the end of a **(1242) Beige** line long enough for the **Hook** to engage the **Eyebolt** on the inboard end of the **Boom** then through the outboard **5mm Single Block** back through to the inboard **5mm Double Block** and then down to the **Fife Rail**. Rig these two **Boom** lines to the **Booms** and form a small bundle of the excess line after the **Double Block** and hold with a small spring clip.

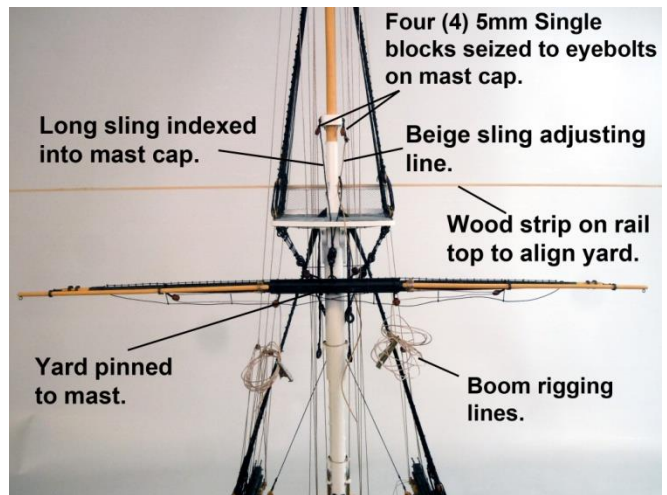
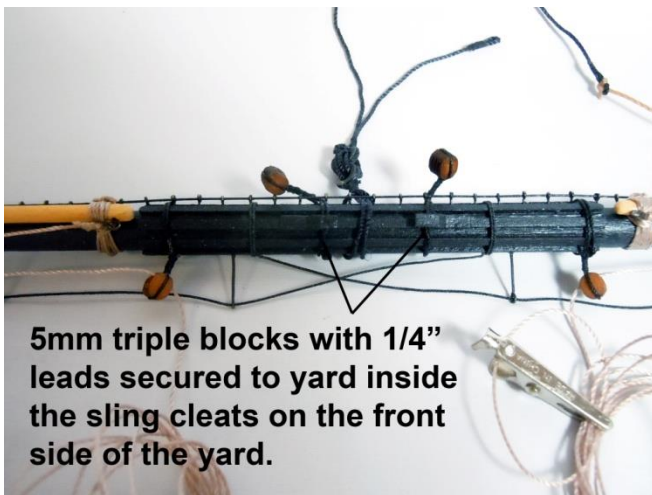

Yard Placement: Now index the **Yard** locating pin into the locating hole drilled in the **Mast**. A drop of **Medium CA** may help and let set. Place a wood strip on top of the **Guard Rail** to help align the **Yard** level as the **CA** sets. Once the glue has set index the longest side of the **Long Sling** with the **(1242) Beige** line up through the opening in the **Fighting Top** index it into the guides on top of the **Mast Cap** and back down through the small loop on the end of the short side and snug up tight and seize to itself. Add a mix of 50/50 glue to the knot and trim the excess. See picture above.

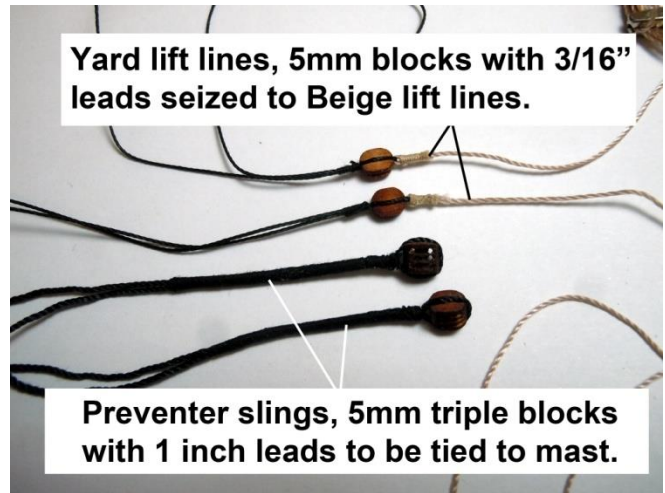
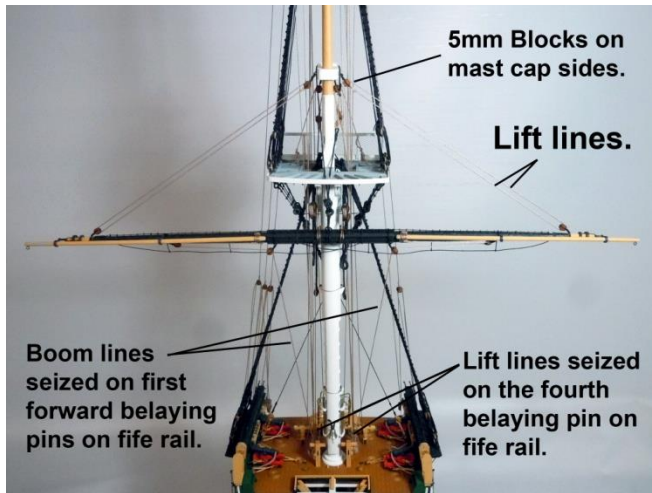

Lift lines: Strop and rig two (2) **5mm Blocks** with **(1210) Black** line trapping 30" lengths of **(1242) Beige** line and seize then at the **Blocks** with 3/16" leads as seen in the picture above. Tie the **Blocks** to the **Eyebolts** on the forward sides of the **Mast Cap**; then index the **Beige Lift** line through the upper **Block** at the outboard ends of the **Yard**, then back up to the **Block** at the **Mast Cap** and down to and seize on fourth belaying pin on the **Fife Rail**. When seizing at the **Belaying Pins** make sure to maintain the **Yard** level and adjust as needed before adding a drop of mixed glue on the seizing. When the glue has set, trim off excess line at the **Belaying Pin**. See picture above.

Boom Lines: Undo the **Boom** line bundles and seize at the first **Belaying Pin** making sure the lines are evenly taut. Add a drop of glue mix and trim excess line when glue has set.

Preventer Slings: Strop and serve two (2) **Preventer Slings** with **(1210) Black** line and using **Triple Blocks** with one (1) inch leads as see in the picture above. Seize the two **Preventer Slings** on the **Mast** through the opening in the **Fighting Top** over the side **Chocks** on the **Mast** so that there is a small gap between the sets of **Triple Blocks** on the **Yard**. See the picture on the next page. With two (2) 12" lengths of **(1242) Beige** line tie a common knot in one end and index the lines though the lower right rear of the **Triple Block** and then to the upper **Triple Block** rig the lines through the Block holes and then down and seized on the fifth **Belaying Pin** on the **Fife Rail** making sure the lines are evenly taut. Add a drop of glue mix and trim excess line when glue has set. See picture on the next page.

Yard Truss: Using the **(1244) Beige** line seize two (2) 12 inch lines with one end seized to 3/16" cast rings. Index the loose end of one through the top hole in the **Mast Fairlead** from the starboard side and the second through the bottom hole from the port side. Now index the loose ends through the **Cast Rings** and forward on each side of the **Mast** under the **Yard** wrapped around the **Yard** below the **Jackstay** line and up through the opening in the **Fighting Top**. See pictures on the next page.

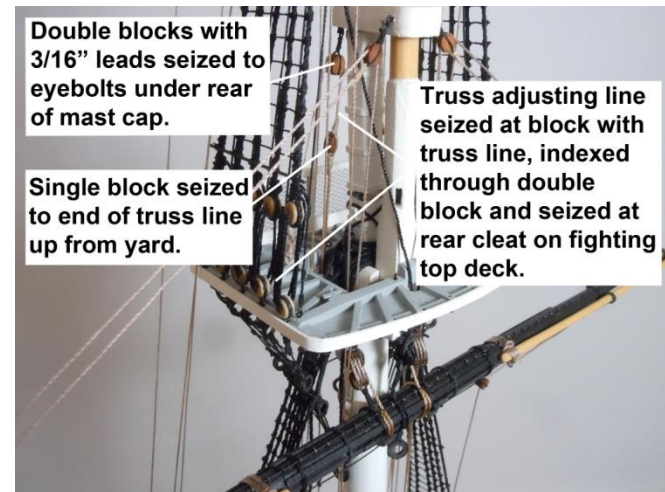
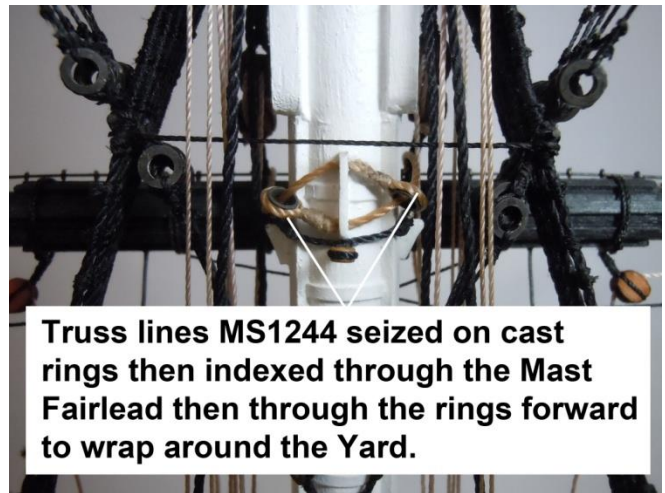
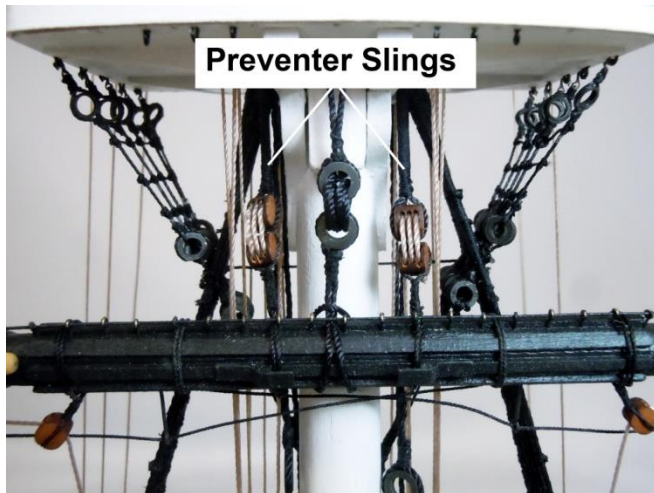

With the truss lines up through the **Fighting Top** seize a **5mm Single Block** about half the distance from the **Fighting Top** deck and **Mast Cap**; but also trap and seize a **12" (1242) Beige** line at the **Block**. Apply a mix of glue to the seizings and when dry trim off excess line. Next seize two (2) **5mm Double Blocks** using (1210) **Black** line with 3/16" leads to the two (2) **Eyebolts** at the aft underside of the **Mast Cap**. Index the (1242) **Beige** lines on the **Single Blocks** through the **Double Blocks** back down through the **Single Blocks** back up to the **Double Blocks** and down to the aft **Cleats** on the **Fighting Top** deck. Apply a mix of glue to the **Cleat** seizings and when dry trim off excess line. See pictures above and on the next page.

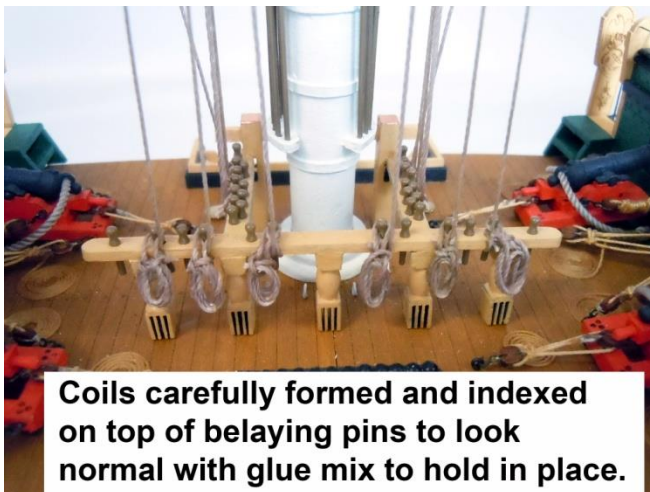
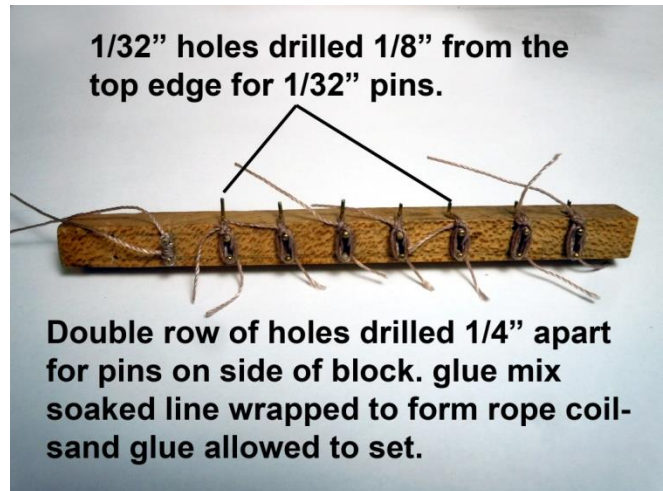
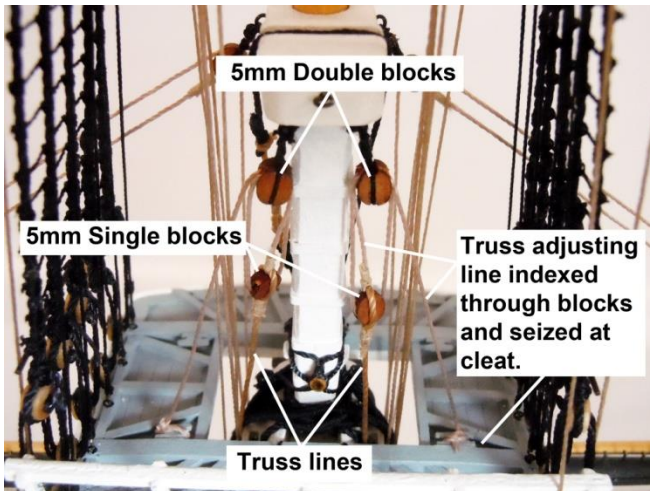

Coils: Twenty (20) **Belaying Pin** and two (2) **Trammed** rope **Coils** will be needed. They are made using the rope cut offs of the appropriate size. Use a scrap block of wood and drill a row of 1/32" holes 1/8" from the top edge then two (2) parallel rows 1/4" apart below the top row of holes. Soak lengths of line with glue mix and wrap wet around the two side pins once then around the top pin and back down to the side pin two or three times and seize all loops with a half hitch knot and let dry. Remove from **Pins** adjust shape and index the top loop onto the **Belaying Pin** locations and hold in place with glue. The two (2) **Trammed Coils** are made by wrapping line around two side pins and then wrapping line tightly around the lines between the side pins. With a loose end after seizing each coil with a half hitch tie the coils to the line just above the **Cleats** on the **Fighting Top**. See the pictures above.

Hatchway Canopy Frame: Delicate Parts Handle With Care. Gather the eight (8) **Hatchway Canopy Frame** parts, clean and straighten slowly as needed. The **Canopy Frame** is built up using cast parts in a specific sequence for a correct build. Study the pictures on the next page to understand the assembly sequence. Dry fit the four (4) **Frame Rails** into the holes within the castings and the on deck **Hatchway Frame** and adjust if needed to fit. When satisfied with fits then **only** glue the **Side Rails** to the **End Rails** while indexed into holes in **Frame Rails**. **DO NOT GLUE THE RAILS TO THE DECK HATCHWAY FRAME!** Next glue the **Bottom Canopy Frame** with the bottom finial in place indexing into holes on top of the **Rails**. See picture on next page. Then glue the **Diagonal Canopy Frame** with

center hole onto the pin and holes in top of **Rail** corners. Now glue the **Lateral Canopy Frame** in place, lastly add the **Top Diagonal Canopy Frame** with the top finial making sure to center and align it with the bottom finial. See pictures below.

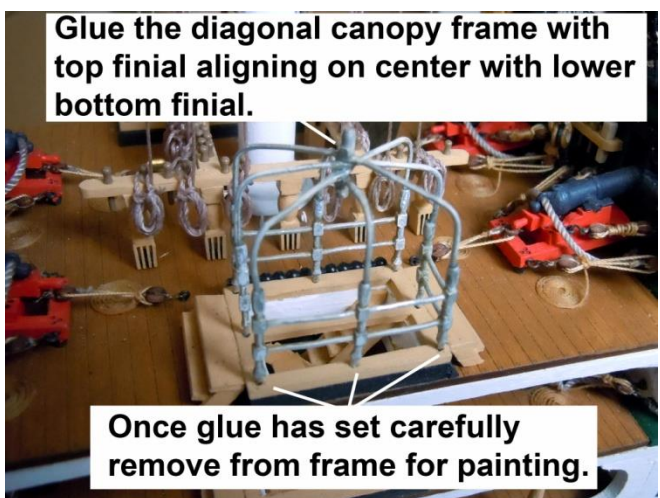
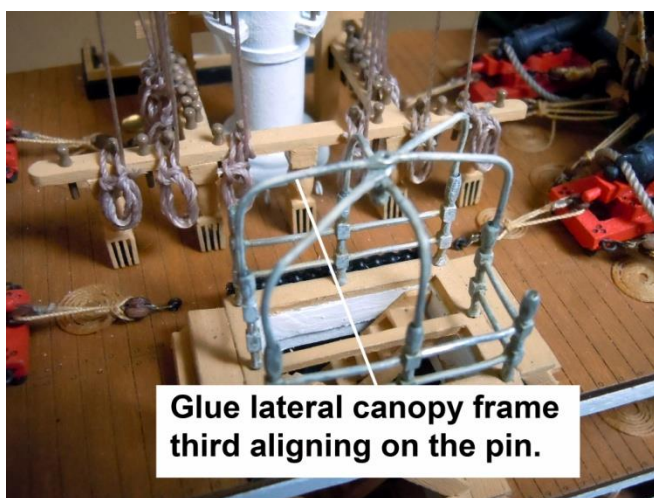
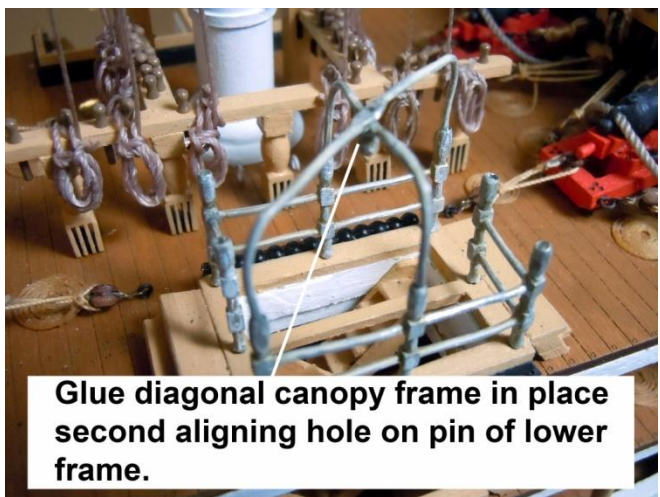
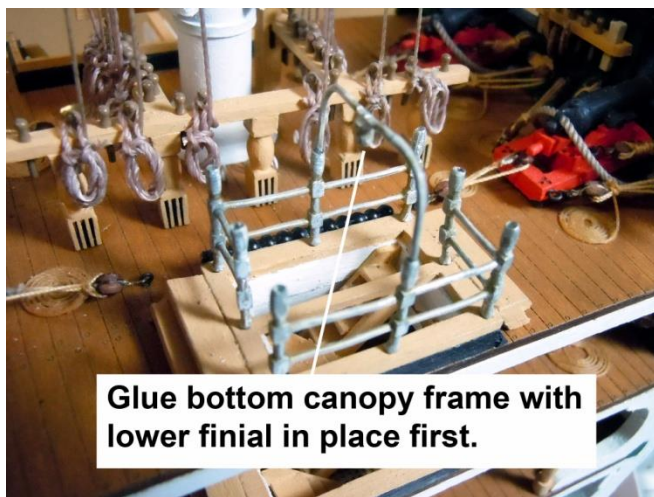
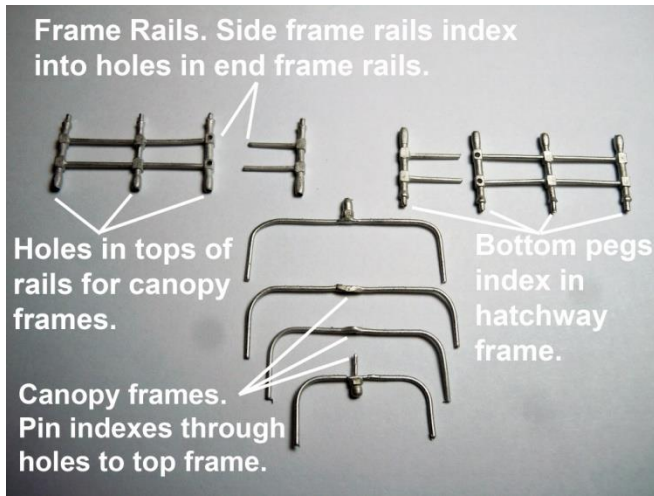

Once glue joints have completely set, carefully remove the **Canopy Frame** by inserting a hobby blade edge under the bottom edges of the **Frame Rail** posts and evenly pry up the **Frames** and remove for painting. Best finish results are obtained by spraying if possible first with primer and then **Gold Metallic** paint. When paint has completely dried then refit the painted **Frame** back in place. See picture below.

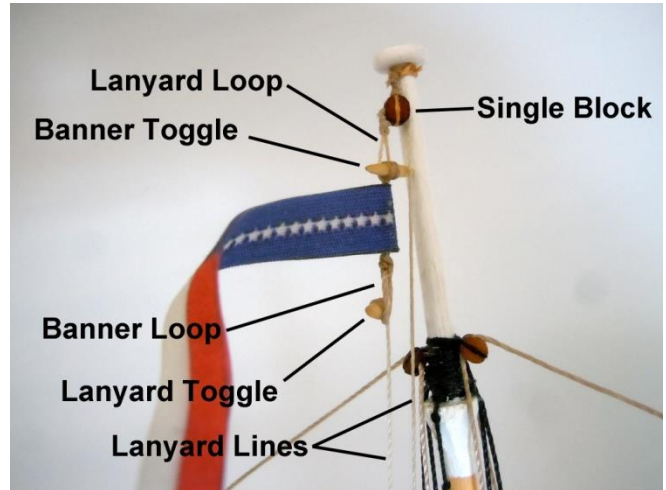
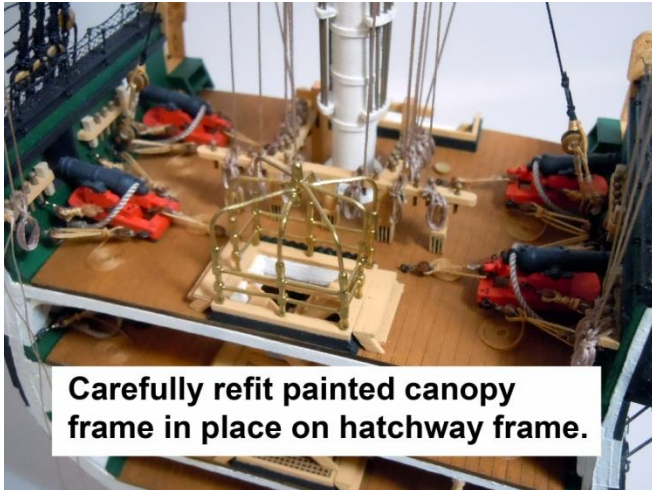

Main Mast Banner: The **Banner** is printed on a very fine fabric. First, dry fold the **Banner** by aligning the tail ends by holding to the light and then press fold on the centerline of the **Banner**. Next, on a piece of wax paper place the **Banner** images down and completely soak the **Banner** with a 50/50 mix of white glue and water. When dry this will allow clean cuts with no thread fraying on the edges when cut with scissors. See pictures below.

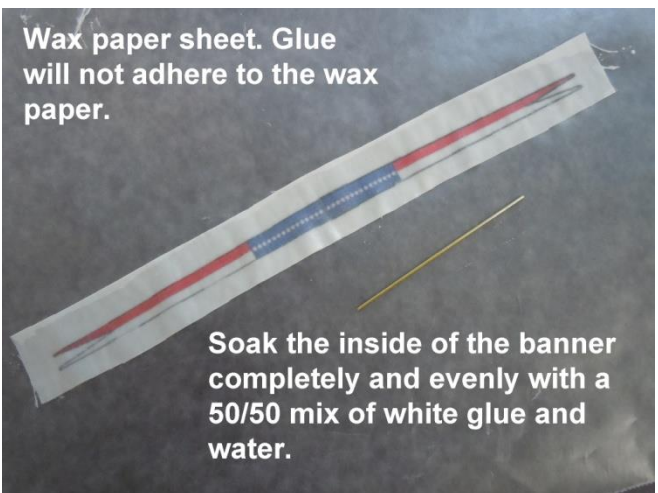
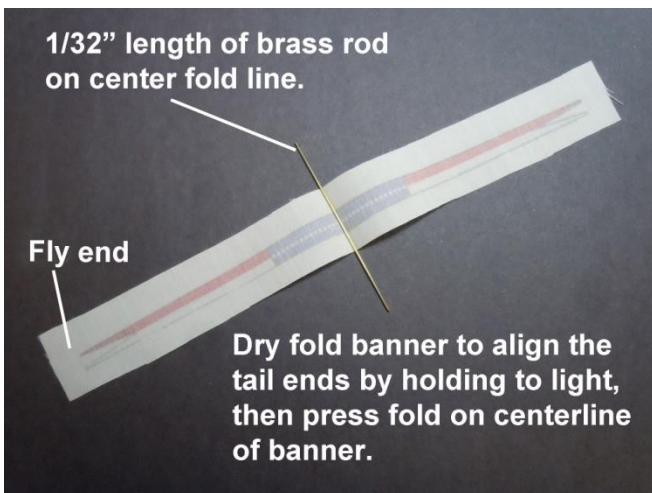

With the **Banner** evenly soaked; place a length of 1/32"**Brass Rod** on the center fold line and carefully fold the one half over the rod and make sure to align the fly ends and blue edges of the **Banner**. Obtain a scrap parts carrier sheet then fold the **Wax Paper** very carefully over the wet **Banner** with the 1/32"**Brass Rod** in place. Now index the edge of the carrier sheet against the **Brass Rod** pressing down tight and flat to form a tunnel in the **Banner**. Weight down the wood carrier sheet evenly and let set over night. The glue once set will be clear and release from the **Wax Paper**. See pictures on the next page.

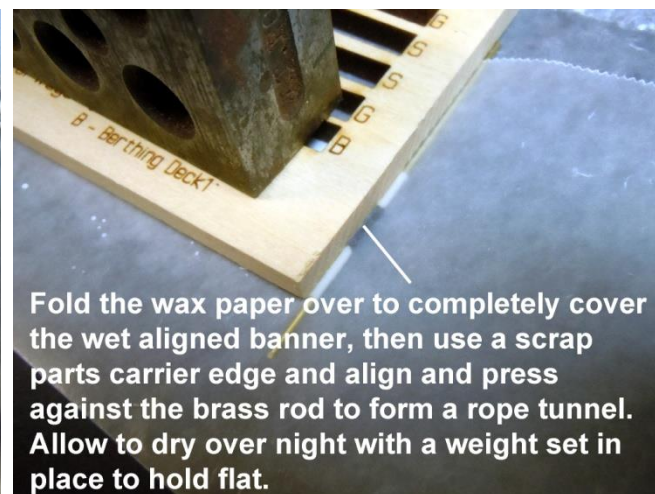
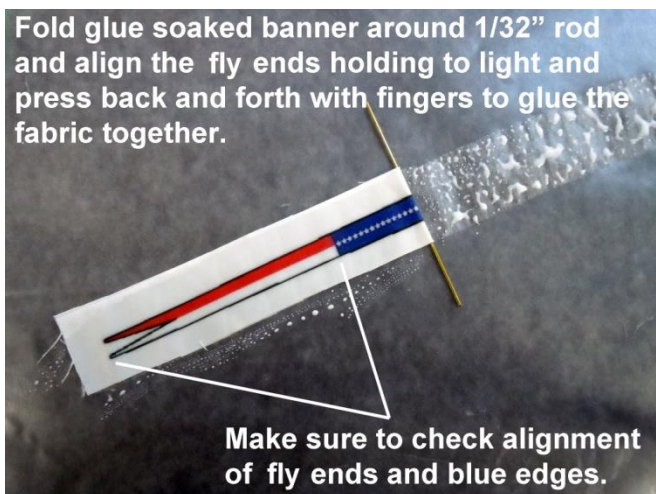

While waiting for the **Banner** glue to set carve two (2) **Toggles** using 1/16" diameter wood dowel 1/4" long tapered from the center with a gullet cut on the center to receive the **Lanyard Line**. Before cutting from the main dowel soak the **Toggle** with CA glue and this will harden the small part from breaking. Once the CA has set cut from the main dowel. See picture below. Once both **Toggles** are ready, seize a 5" length of (1246) **Beige Line** to the gullet of each **Toggle** with a clove hitch and half hitch. Then add a drop of CA to the end of the line to harden the end for easier inserting through the **Banner** tunnel.

Once the **Banner** is set and removed from the **Wax Paper** carefully remove the 1/32" brass rod from the center leaving a tunnel for the line to feed through. See picture below.

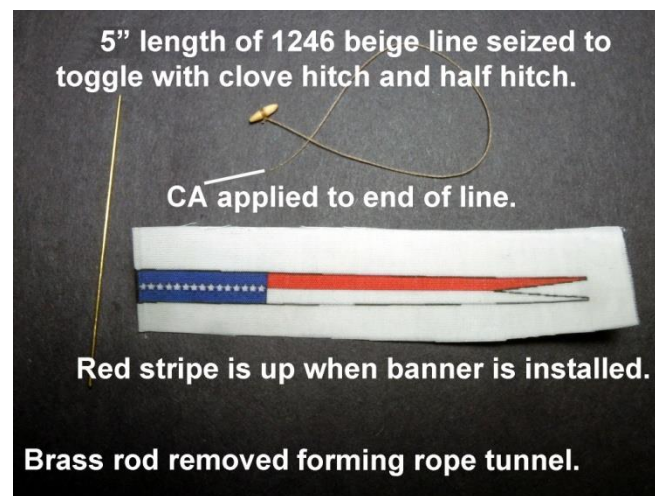
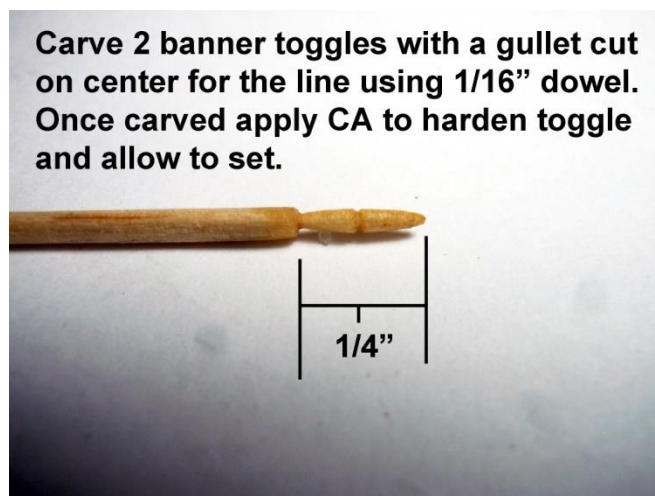

With sharp scissors carefully cut the fly end off against the red and white colors. **Note:** Black outline was printed as a cutting guide and all black should be cut away carefully. Next cut the fly end "V" notch out. Then finally cut away the side lengths through the tunnel making sure to cut away the black outline.

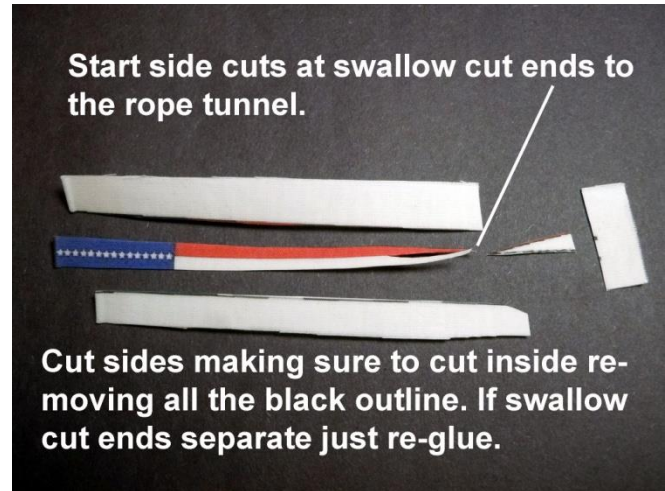
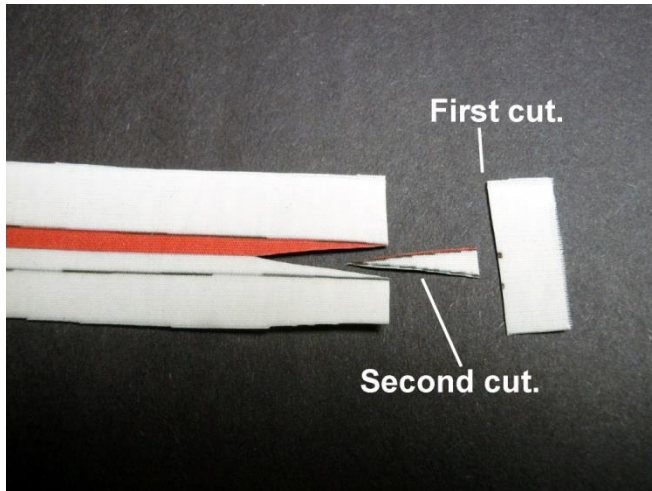

Carefully open the tunnel ends if crimped when cut with the scissors using a tooth pick or scribe. Insert the length of rope with the red color of the **Banner** up using the hardened rope end like a needle. Next, tie off a loop large enough for the **Toggle** to fit through and as close as possible to the bottom edge of the **Banner**. Now carefully with your fingers form the **Banner** as if blowing in the wind. See picture below.

Cut a length of **Lanyard** line using **(1246) Beige line** from the top of the **Mast** down to the last **Belaying Pin** on the port side **Pin Rail** and then back up to the top of the **Mast**. Note the **Lanyard** is tied off as an endless loop line, so once the line is indexed through the **Single Block** one end is tied to the **Toggle** while the other end has a small loop tied for the **Banner Toggle** to fit into. Take care to test fit to allow enough line to be tied off on the **Belaying Pin**. **Make sure to index the line through the Single Block before tying the Toggle Loop on the Lanyard Line.** See pictures below

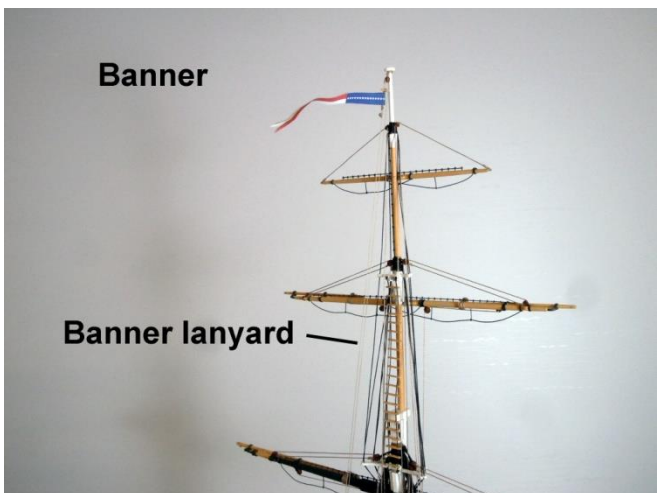
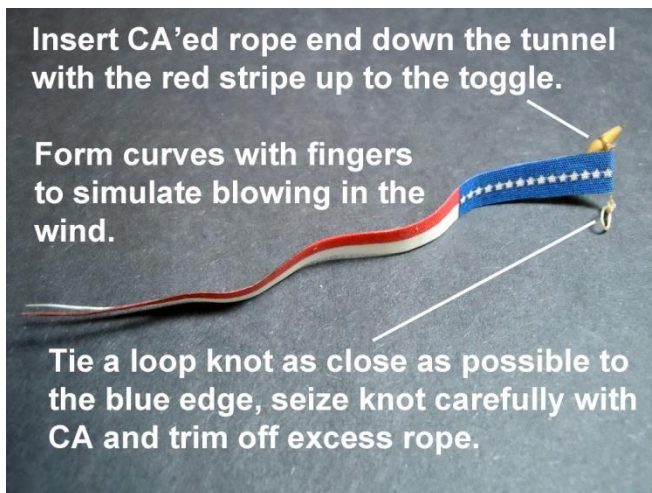

Now add the **Banner** to the **Lanyard** line fitting the **Lanyard** loop onto the **Banner Toggle**. Then fit the **Lanyard Toggle** into the lower **Banner Loop**. Now tie off the **Lanyard** to the last **Belaying Pin** on the port side taut enough to hold the **Banner** in position on the top **Mast**. **DO NOT** glue the **Lanyard** onto the **Belaying Pin**, this will allow for future adjustment of the **Lanyard**. See picture on the next page.

The model is now complete, sit back and enjoy your fine work and build.

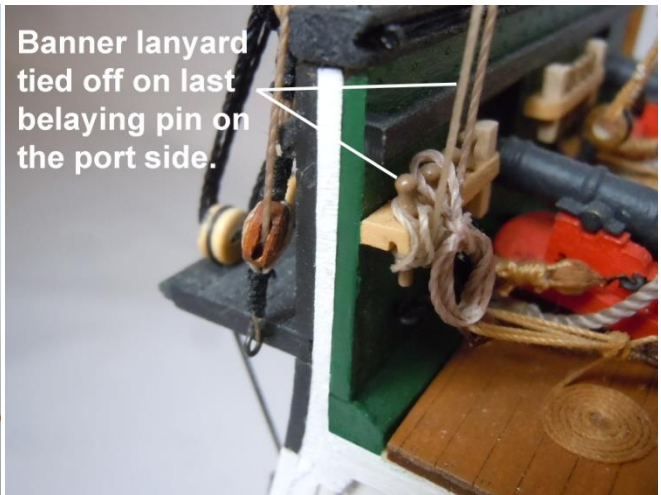
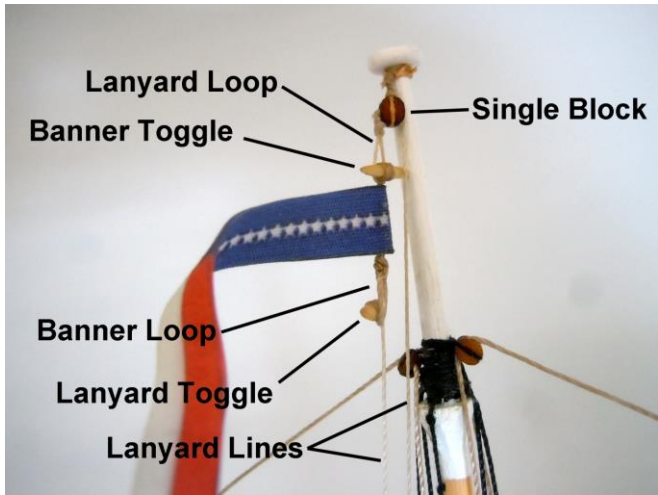

Reference Pictures:



