

Building a Western Mountain

# BUCKBOARD WAGON

CIRCA LATE 1800 - 1900'S



## INSTRUCTION MANUAL

KIT NO. MS6004

Technical Characteristics:

Scale 1:12, 1" = 1 foot

Length 9.75"

Width 5.25"

Height 5.25" (minus whip)

Kit design, plans, instructions, and prototype model by Ken Foran, 2012

©2013 Model Shipways, Inc.

[modelexpo-online.com](http://modelexpo-online.com)



## Before You Begin

The Western Mountain Buckboard is a historic and distinctly American vehicle and makes a splendid model. The buckboard originated in the mountainous areas of the north eastern states and the design moved west with pioneers and evolved into a pleasure and utility vehicle. The original versions were nothing more than a seat bolted to a long spring board attached to two axles. Over time, more refinements were added for pleasure and enjoyment. This model is an example of that evolution with the addition of the front spring and the rear Shuler Spring. The rear Shuler Spring combines the features of the helical coil and torsion spring enabling the vehicle to withstand the rigors of rough mountainous terrain due to its flexibility of design. This three point suspension concept was later adopted by the Model T automobile. At 1" = 1' 0" (1:12) scale, it is relatively easy to build and obtain precise detail. Laser-cut parts offer a simple building method. Britannia (white metal) fittings, and brass photo etch parts eliminate creating parts from scratch.

Before starting the model, carefully examine the kit and study the plans and the instruction manual. First, determine if all the listed parts are present using the Materials List. Handling them will produce a better understanding of the kit's requirements. Try to visualize how every piece will look on the completed model. Look at and study the reference photos at the end of these assembly instructions.

Also, follow the suggested building sequence and what must be done first, or ahead of time and what can be done simultaneously if you wish. For example, you may want to skip to the end of this manual and begin the wheel construction as you are working on other parts or waiting for glued assemblies to set.

### The Plans

Overall plan sheets are provided. The plans are one in an isometric format illustrating the construction sequence and identifying the parts and their placement. Sheet 1 shows the layout of the parts on the laser cut wood sheets and identifies the parts by name. It also shows the photo-etched brass sheet and identifies these parts. These drawings are to no particular scale, being illustrative of the construction sequence and sized to fit on the sheet. There are no parts to be made by referring to a full size plan. Some items are drawn to full scale and are so noted on the plan sheets.

### Make Allowances during the build.

Try to be exact when following the instructions, but use common sense. Adjustments may be necessary to compensate for small differences in how your model is shaping up and how the parts are relating to each other. An old saying in the model building craft is that "if it looks right, it is right."

### Kit Lumber

Basswood strips and laser cut sheets of basswood and plywood are supplied in the kit. Sorting the wood in the kit by dimension is a good practice. After selecting and cutting what you need, return the remaining stock to the proper dimension pile. Don't worry about using a piece for one item intended for another. Model Trailways supplies enough extra wood to complete the model before running out.

**A word about laser cutting:** a common misconception is that the parts should punch out of the carrier sheet. This is not so. Laser cut parts are retained in the carrier sheet by small bridges of uncut wood called tabs. Tabs can be oriented parallel to the grain or perpendicular to the grain.

It is always better to cut through these tabs rather than try to punch out the parts by breaking the tabs. This is particularly true of laser cut plywood. Plywood is much more difficult to laser cut than basswood. You may have to cut through not only the tabs but portions of the part outline that did not cut completely through the sheet. Turn the sheet over and cut from the backside to release the part without damage.

### **Britannia Metal Fittings**

There are many Britannia (white metal) parts and fittings in this kit. First, remove any mold joint flash with a #11 hobby blade, then file or sand with fine sanding stick or sandpaper. Second, wash fittings in dishwashing liquid and warm water to remove traces of mold release agent and the body oils your fingers deposit. Allow the parts to dry thoroughly before applying primer and painting. For applications where it is required to glue a Britannia part to wood, it is a good idea to rough up the Britannia gluing surface with a sanding stick or sandpaper.

### **Wheel Hubs and Axles**

The wheel hubs in the kit are precision machined. The axles are cast Britannia metal. It is important to check the fit of the hubs on the axles at the outset before beginning the kit. Being cast, the axles will likely have a tiny bit of flash preventing a running fit on the hubs. Use a sanding stick to work the axles until the hubs fit and run freely. The axle can be easily bent, so work carefully. If you should happen to bend an axle, it can be straightened, also avoid paint build up when painting the axle.

### **Working with Brass**

The brass in the kit is a photo-etched sheet. Use care when cutting the square nuts from the sheet.

The etching process causes a slight angle on the edges of the square nuts which you may wish to file square for greater authentic detail. The brass rod will need to be formed in a U shape using small needle nose pliers.

**Glues:** White or Weldwood glue will work well for most applications. Five-minute epoxy provides extra strength for some cases. Super glues, such as Jet, Flash, or Zap, produce quick adhesion. For most applications, the medium viscosity, gap-filling variety is best. The thin type is recommended for filling a narrow crack and wicking into laminate joints. We will refer to super glues as CA (cyanoacrylite).

A word about gluing laser cut parts. Laser cutting burns through the wood and leaves a charred surface. This charred surface does not make good glue joints. It is recommended to lightly sand or scrape away the loose char before gluing. It is not necessary to remove all the char, unless a finished wood surface is required. In some cases simply scraping with a # 11 blade is sufficient.

**Clamps:** Clamps are an essential part of the model building experience. In the full size boat building arena it is often said, "A boat builder cannot have too many clamps." This is true of model building also. There are so many situations in the course of building a model that require a particular type of clamp. The photo below shows a typical collection of clamps that are useful in model building.



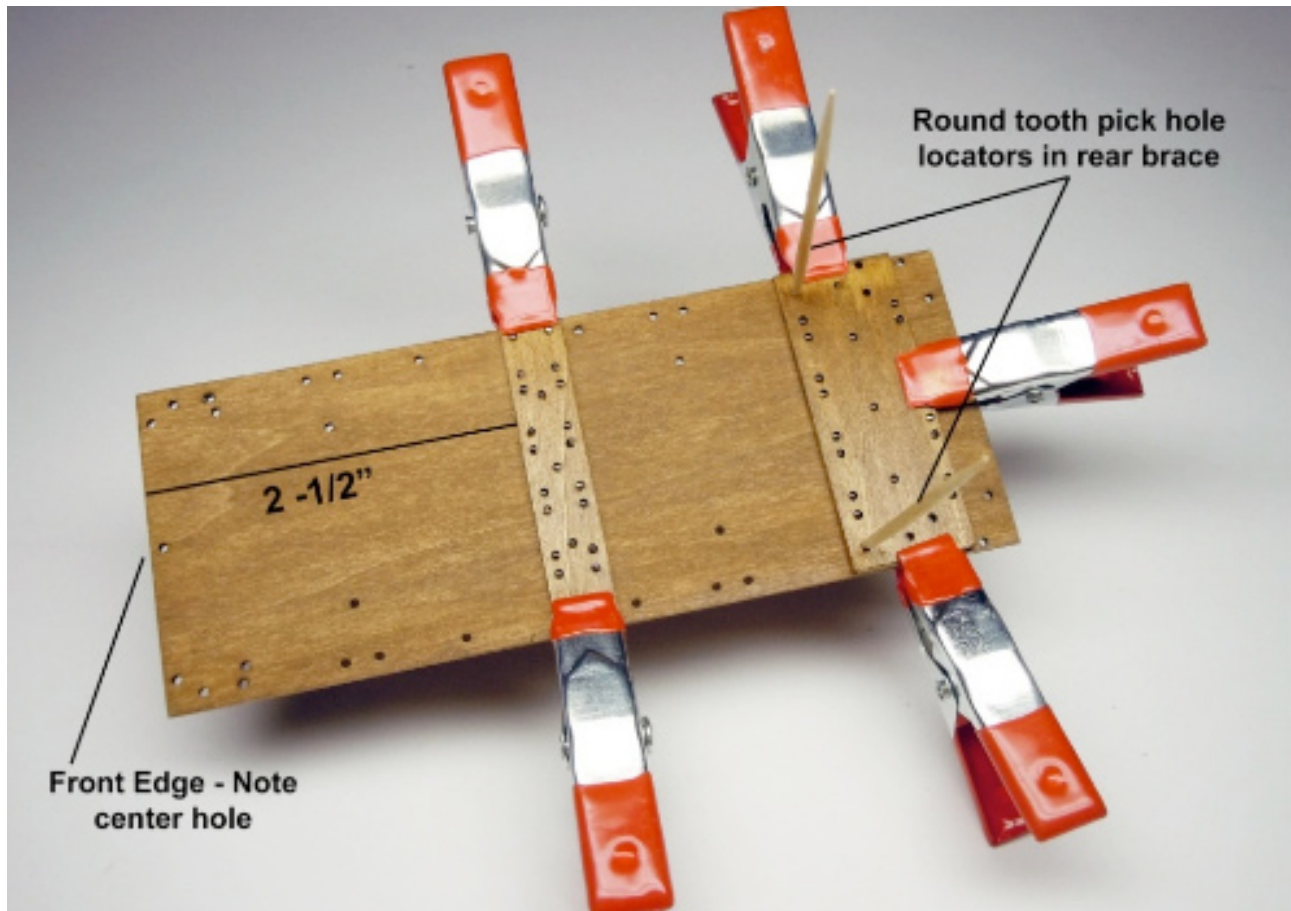




# Western Mountain Buckboard Assembly Instructions

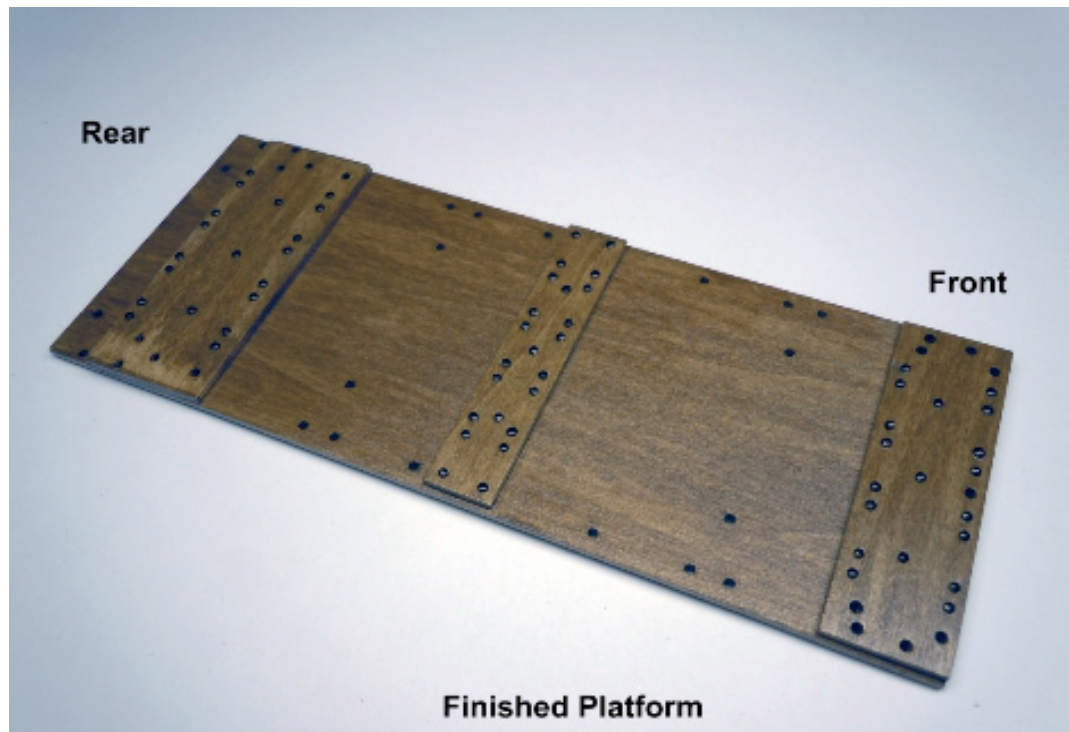
## Building the Platform Base

1. Remove the platform parts – Platform, and three cross braces from the 1/16th sheet WB-1 by cutting the connector tabs with a sharp #11 Xacto blade.
2. Sand all edges to remove tab burrs and excess burned char, and then lightly sand all top and bottom surfaces to remove any burn residue characteristic of laser cutting.
3. Use water based wood stain (MS4975 English Oak). Water based stains assure compatibility with most glues including CA once dry. Solvent based stains DO NOT always allow glue adhesion over time. Stain parts on all edges and surfaces.
4. After stain is completely dry spray parts with a Clear Matte Finish. When dry sand lightly to smooth surface and then spray a second time.
5. The three cross bases have small starter holes to receive the #8 pins that simulate the screw heads. Paint the pin heads first with a primer then with Satin Black paint by sticking them into a scrap piece of cardboard, 65 in total. Starting with the center brace and insert the painted pins (23) in the starter holes using needle nose pliers. Work carefully and hold the pin near the point to press fit into the holes and then press in all the way so that the pin head is flush to the surface. Repeat pin insertion for the front and rear braces.
6. Carefully apply a drop of CA glue to the pin shafts to securely glue the pins in place.
7. Once the CA is set then using small end cutters, carefully cut off each pin shaft as close as possible to the wood surface. Should any pins loosen during cutting, just glue again. When cutting pin shafts off hold the parts down into a wastebasket and wear safety glasses.
8. Once all pins are cut off; then using a mill bastard file, CAREFULLY file the pin shaft ends flush with the wood surfaces. Should any pins loosen during filing, just glue again.
9. Determine the bottom front edge of the platform; the front edge has a bolt hole in the center along the edge. The top has the laser lines replicating the individual boards. Then measure 2- 1/2” from the front edge and draw a light reference line on each side of the platform using the laser cut building square supplied on WB-1.



**Photo 1** Locating and gluing cross braces.

10. Glue the front edge of the center brace in place aligned with the reference lines and using small spring clamps hold the side edges in place. Check with building square. (see photo 1)
11. Glue the rear cross brace in place using round toothpicks as locators to align all the holes. Use spring clamps until glue is set. Repeat step to glue front brace in place, make sure the front edges of the brace and platform are flush. Again align all the holes.
12. Remove spring clamps once glue is set on all braces and spray top and bottom of platform with Clear Matte Finish for final coat and set aside to dry.



**Photo 2** Bottom view of completed platform with screw heads

### **Build Drilling Jig**

1. Remove drill jig base 1" x 4" x 3/32" plywood from WB-3 plywood sheet
2. Remove drill jig spacer 1/2" x 4" x 1/64" from WB-4 plywood sheet.
3. Glue spacer to drill jig base and align along one edge and ends of base.
4. Remove the small square from WB-1 1/16" sheet, sand edges then draw a reference line across the center line of the drill jig. This will aid in aligning the drill bit when drilling through parts. (See Photo 3)

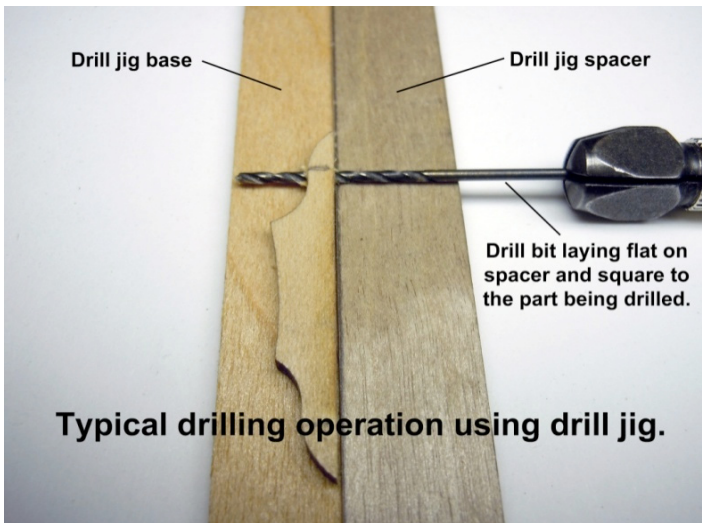
### **Build Wheel Fixture**

1. Remove large square with hole in center from WB-3 the 3/32" plywood sheet.
2. Locate 1/8" x 1/8" x 12" Basswood strip and cut eight (8) 1 inch pieces.
3. Glue the 1" strips diagonally across each corner of on both sides square fixture. (See Photo 25)
4. This wheel building fixture will also work as a flat working surface for seat spring assembly. (See Photo 5)

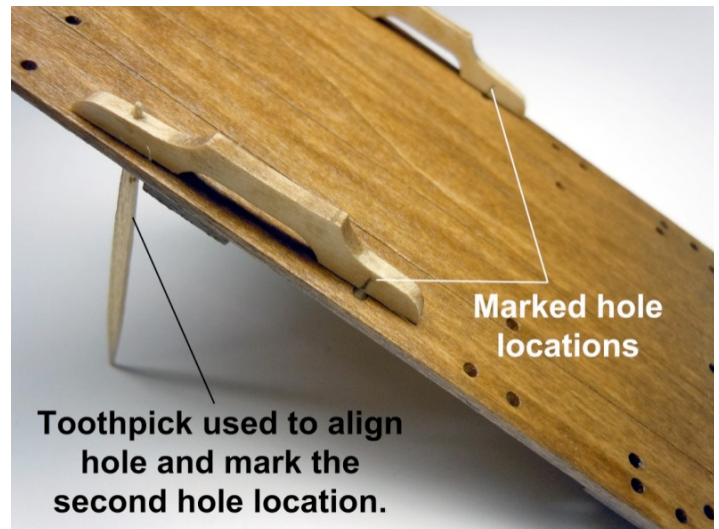
### **Platform Seat Spring Brackets – 2 needed.**

1. Remove the two (2) platform spring brackets from WB-2 the 3/32" basswood sheet.
2. On both, lightly draw a reference line 1/4" from front edge of bracket on the side of the part.
3. Using the drill jig carefully drill a hole on the center of the reference line with the flat edges of the brackets against the 1/64" spacer edge using a #55 drill bit held in a pin vise. Care must be used to keep the drill bit flat on the jig surface and square using the reference line drawn on the drill jig. (See Photo 3)





**Photo 3** Using drill jig.

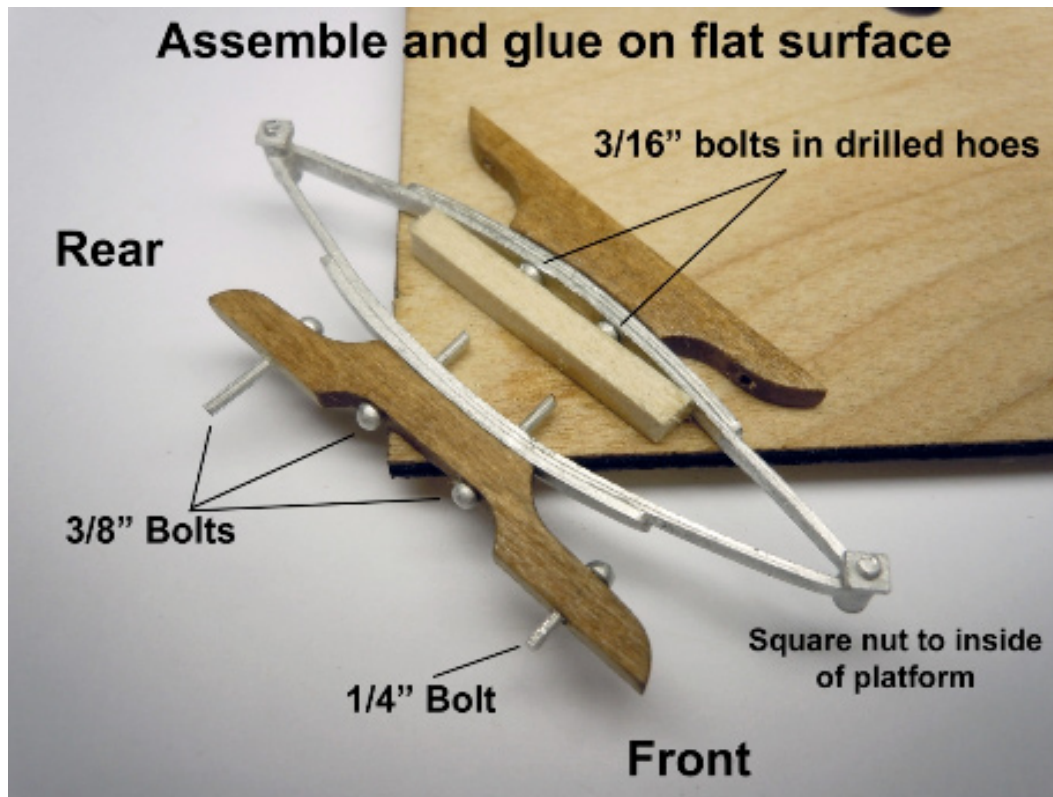


**Photo 4** Locating and marking holes.

4. Insert two round toothpicks into holes 3 inches from the front edge of the platform from the bottom side of the platform and set the bracket on the tooth pick end. (See Photo 4)
5. Carefully pivot the brackets to see the second hole locations in the platform and draw marks for the center of the holes on the side of the brackets. (See photo 4)
6. Drill the second mounting holes in the brackets using the #55 drill bit.
7. Locate the center of the curved top surface and mark a reference center line. Measure  $\frac{3}{16}$ " in each direction from the center and mark drill locations for two holes  $\frac{3}{8}$ " on center. Once marked drill holes through center of bracket using drill jig with #55 drill bit.
8. Once holes are drilled and dry fitted with hole alignments checked; then stain and Clear Matte Finish.
9. Locate the two cast seat springs and using the cast in hole locations carefully drill using #67 drill bit in all eight (8) holes in springs. Then enlarge holes using #55 drill bit.
10. Clean and file smooth all parting lines and then prime and paint with Satin Black paint.
11. Insert four (4)  $\frac{3}{8}$ " long painted round headed bolts into the central holes from the bottom side of the brackets and through the holes in the painted seat springs with glue applied to the mating wood/spring surfaces. (See Photo 5)
 

**Note: The square nuts face inboard in final assembly and the high side of the wood bracket is to the rear. Lay on a flat surface to allow the glue to set.** These are the seat spring mounting bolts that MUST be in place first before gluing seat mounting brackets to platform.
12. Insert and glue one (1)  $\frac{3}{8}$ " long bolt in the rear hole of the bracket and one (1)  $\frac{1}{4}$ " long bolt in the front hole.
 

**Note:** the longer arm of the platform bracket is to the front of the platform. (See Photos 4 & 5)



**Photo 5** Seat spring assembly.

13. Once all the round head bolts are in place glue the spring to the upper and lower wood brackets. Allow glue to dry and add four (4) small nuts to the four (4) central 3/8" long bolts and then trim bolt shafts to proper length and file square. Touch up with paint.

#### **Seat Spring Brackets** – 2 assemblies needed a left and a right.

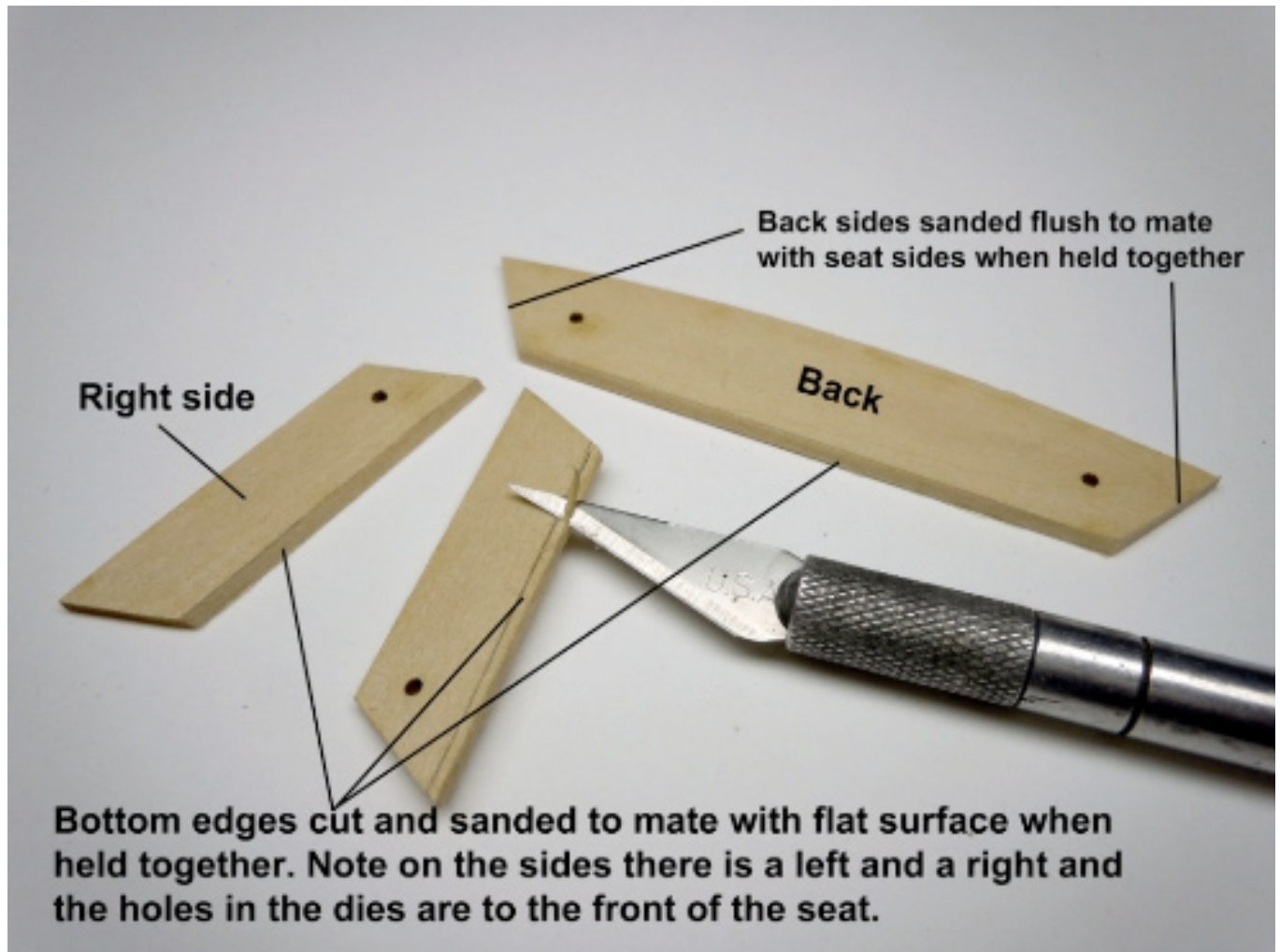
1. Remove two (2) seat spring brackets from WB-2 the 3/32" basswood sheet. Note: in looking at the side profile of the bracket the arc has a high end. The high end **MUST** orient to the rear of the platform when assembled to top surface of the seat springs. This enables the seat surface to tilt slightly forward. (see photo 5)
2. Center the flat edge of the seat spring bracket front to rear next to the holes in the seat base and mark the center of the hole locations. Use the drill jig to drill #55 holes through the center of the brackets. Then mark the centerline of the bracket along the flat edge and transfer the centerline marks to the arced edge. Then mark left and right of the centerline 5/32" for hole locations. These are two (2) hole locations on 5/16" center-to-center, the same as the mating spring holes.
3. Carefully drill four (2) holes about 1/8" deep into the arced surfaces using the #55 drill bit.
4. Apply glue to the arced surface of the bracket, insert two (2) 3/16" bolts and glue bracket to spring surface and let the glue set on a flat surface. (See Photo 5) **IMPORTANT:** The square nuts on the springs must face inboard in final left and right assemblies. Repeat for second spring/bracket assembly. Set both assemblies aside for later assembly.

#### **Seat Assembly**

1. Remove the seat base from WB-1 the 1/16" basswood sheet. Sand the seat base edges half round on all four (4) sides. Stain and spray with Clear Matte Finish and set aside.
2. Remove seat sides and back from WB-1 the 1/16" basswood sheet. Note: on the side parts

the holes are towards the top edge and on the back part the top edge is arced.

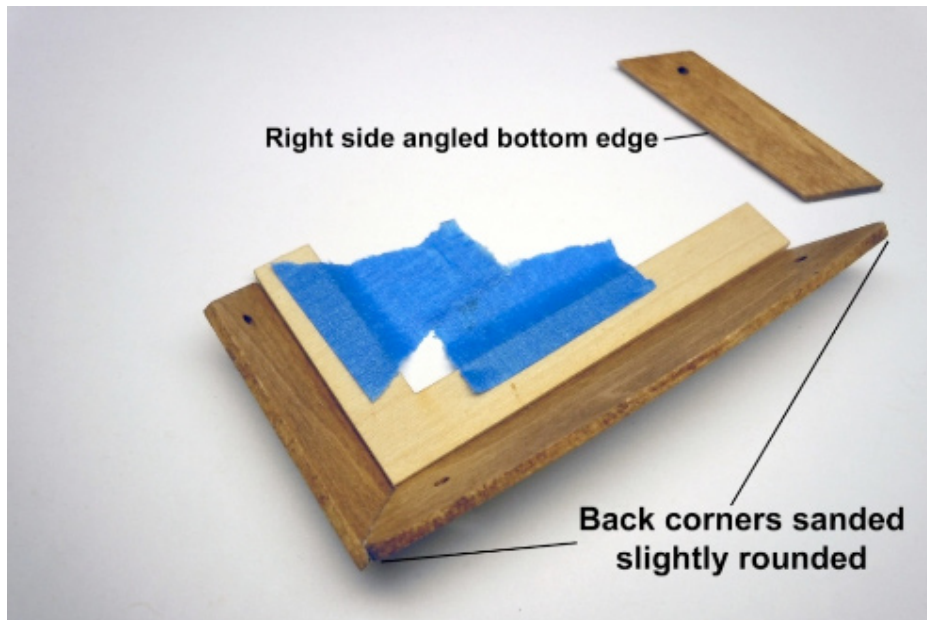
3. Remove the building square from WB-1 basswood sheet and sand the edges smooth.
4. Carefully cut and sand the two angled sides of the seat back such that the edges mate flush with the seat sides when held square to them. Use the building square on a flat surface to check. This is a critical step so take time and dry fit to check. (See photo 6)
5. Carefully cut and sand the two bottom edges of the two seat sides and the bottom edge of the seat back such that when held together will sit flush on the surface of the seat base. (See Photo 6) Also slightly round the two (2) top corners of the seat back.



**Photo 6**

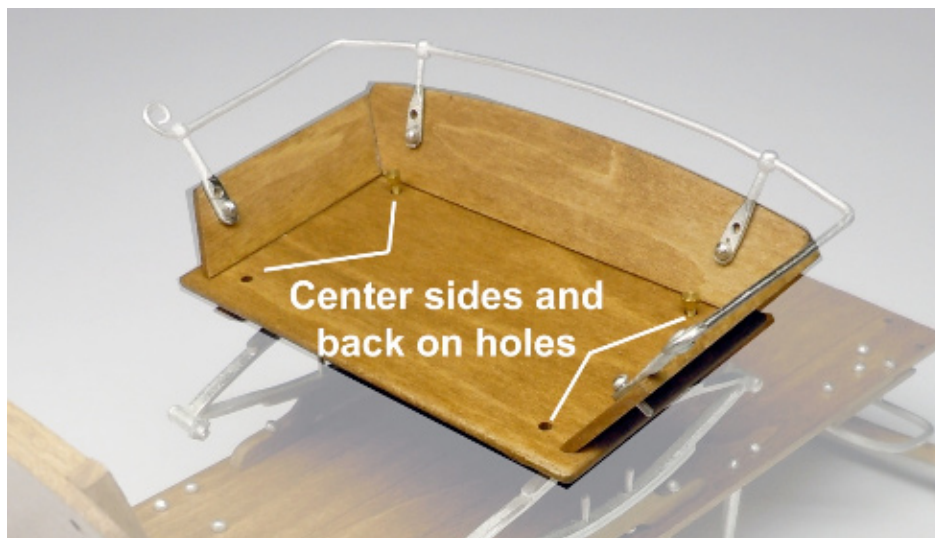
6. Once all edges are dry fitted then stain and spray with Clear Matte Finish.
7. Apply Weldwood glue to one side of the angled edge seat back and glue to the seat side on a flat surface using the building square and let the glue set. (See Photo 7)





**Photo 7**

8. Once the glue is set repeat for the other side.
9. Carefully apply glue to the bottom angled edges of the seat sides and back and then glue to seat base and justify location equally around the mounting holes in the seat base. (See Photo 8)

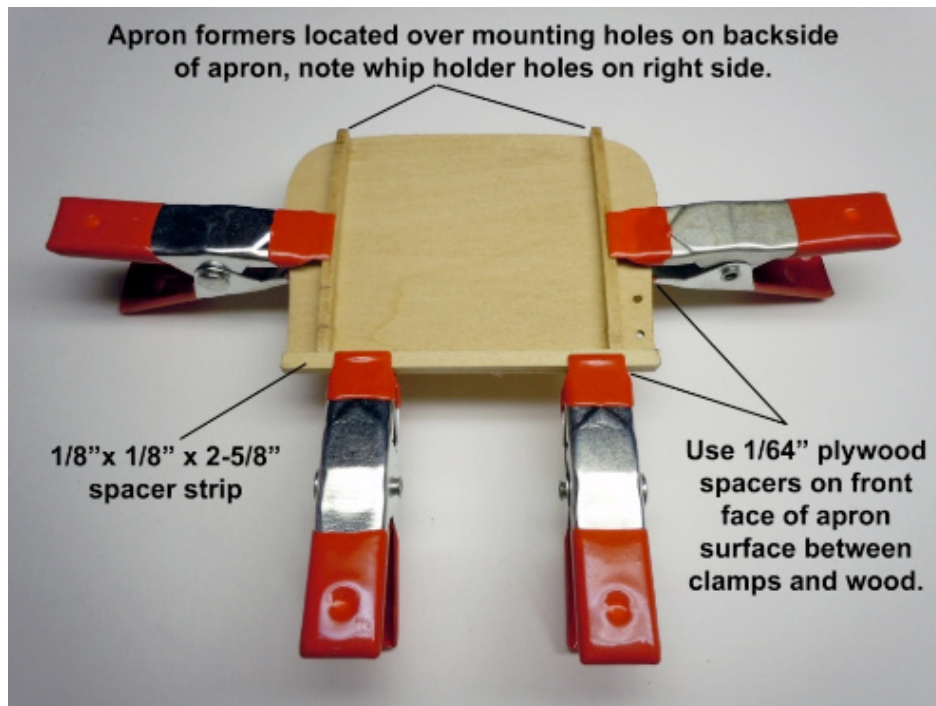


**Photo 8**

10. Clean, smooth and carefully straighten and adjust the seat rail to match the hole locations on the seat sides and back. When satisfied with dry fit prime and paint with Satin Black paint. Then locate and glue in place using (4) 3/16" bolts inserted from the inside of the seat area. Let the glue set. Using #55 drill bit drill the top holes into the wood parts using the mounting flange holes as guides. Insert and glue four (4) 3/16" bolts and then add eight (8) painted 11 square nuts to the bolt ends. The square nuts are from photo etched brass sheet. (See photo 8)
11. Place seat assembly aside as pictured in Photo 8 to allow glue to set and for later use in the build.

## Apron Assembly

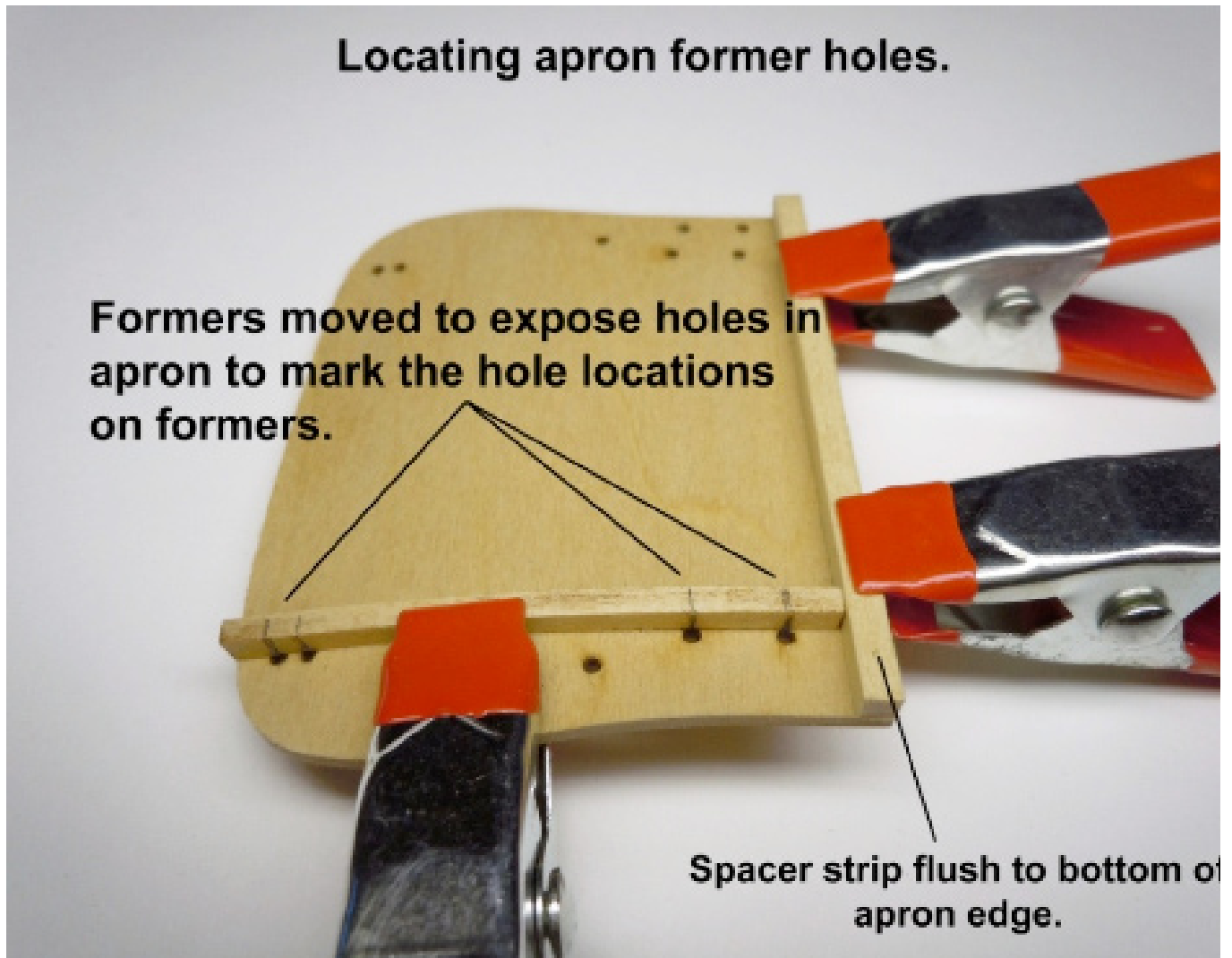
1. Remove apron from WB-1 the 1/16" basswood sheet. Remove Apron formers, two curved and one straight from WB-2 the 3/32" basswood sheet and sand all edges to remove excess char.
2. Stain and spray with Clear Matte Finish the apron and formers and let dry thoroughly before step 4.
3. Cut a 2 - 5/8" long (the width of the bottom edge of the apron) from the 1/8" x 1/8" wood strip. This strip represents the thickness of the front edge of the assembled platform base.
4. Wet the apron under running hot water until the entire wood piece is totally hot. This softens the wood so use 1/64" wood spacers from WB-4 and save for later use building the wheels.
5. Working quickly using spring clamps and the 1/64" plywood spacers (WB-6) on front surface of apron, clamp the 1/8" x 1/8" strip flush along the bottom edge of the apron. Important: the strip must be flush. The inside surface of the apron will have the whip holder holes on the lower right side while looking at it.
6. Locate the two (2) formers over their respective holes in the apron and the bottom edges against the spacer strip and clamp in place using the 1/64" spacers on the front surface of the apron between the clamp and wood in the center of the former. (See Photo 9) Allow the apron wood to thoroughly dry completely.



**Photo 9** – Forming the Apron

7. Once completely dry move the two (2) formers inboard enough to expose the holes in the apron wall and mark the centerline of the holes on the side of the formers. Remove the former clamps and using the drilling jig drill #55 holes in both formers and dry fit back in place and ream holes in both formers and apron wall. Note leave strip clamps in place. (See Photo 10)

## Locating apron former holes.



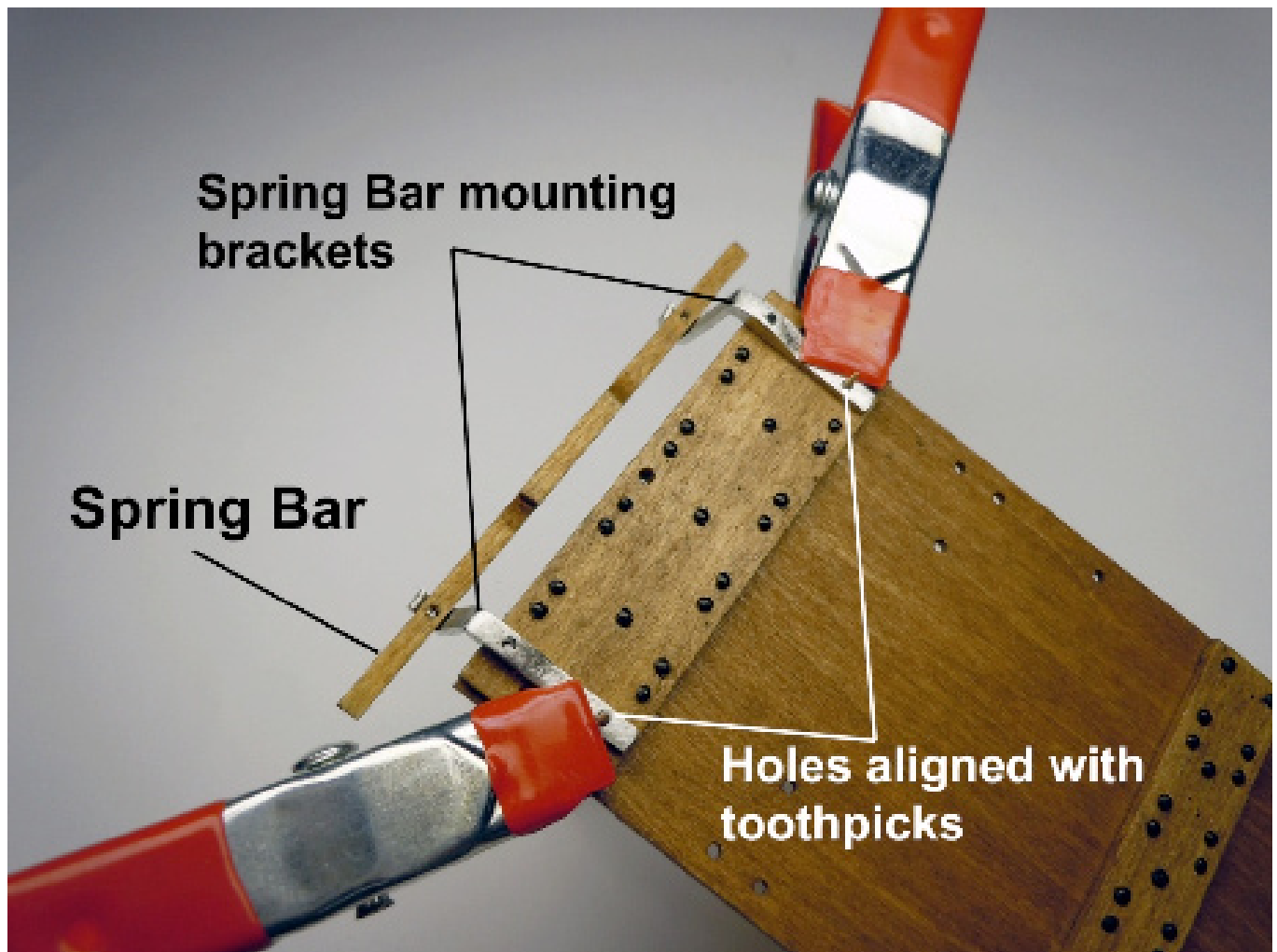
**Photo 10**

8. Using round toothpicks inserted in top and bottom former holes only from the front side of the apron; glue the curved formers in place making sure the bottom edge of the former touches the spacer strip. Do Not glue former to spacer strip.
9. Dry fit the straight former between the top edges two curved vertical formers, carefully trim length if necessary for tight fit then glue in place. Allow glue to set then remove all clamps.
10. When the apron assembly glue is completely set carefully ream all the holes with a #55 drill bit. Trim the top edge of formers to be flush with top edge of apron if necessary.
11. Set apron aside for later assembly.

### Platform Assembly

1. Locate the two (2) painted Front Spring bar mounting brackets and glue to the underside of the front platform assembly. Use round toothpicks to align the holes and make sure the hole in the wood Spring Bar align with the holes in the mounting brackets and glue the spring bar in place with two (2) 1/4" round bolts and two (2) small square nuts on bolt shafts. Note: Let all glue joints set firmly before the next step. (See Photo 11)





**Photo 11**

2. Insert round head bolts from the top surface of the platform and glue (2)  $\frac{1}{4}$ " (rear) and (2)  $\frac{3}{8}$ " (front) long bolts in their respective holes and then add (4) painted brass P.E. square nuts. Then trim the excess length on the bolt shafts by using a spar square nut on the shaft as a guide and cut with end cutters and file flush with spare nut.
3. Glue the two (2) cast 90 degree brackets to the bottom of the two apron formers using round tooth picks inserted from the front surface of the apron. When bracket glue is dry add four (4)  $\frac{3}{8}$ " round head bolts through the front surface of the apron and square nuts and trim excess off of the bolt shafts. Allow complete assembly glue joints to set.
4. Glue apron with 90 degree brackets in place to platform with bottom edge of apron flush to spring bar brackets and bottom edge of front platform cross brace aligning 90 degree bracket holes with platform holes using round toothpicks. (See Photo 12)

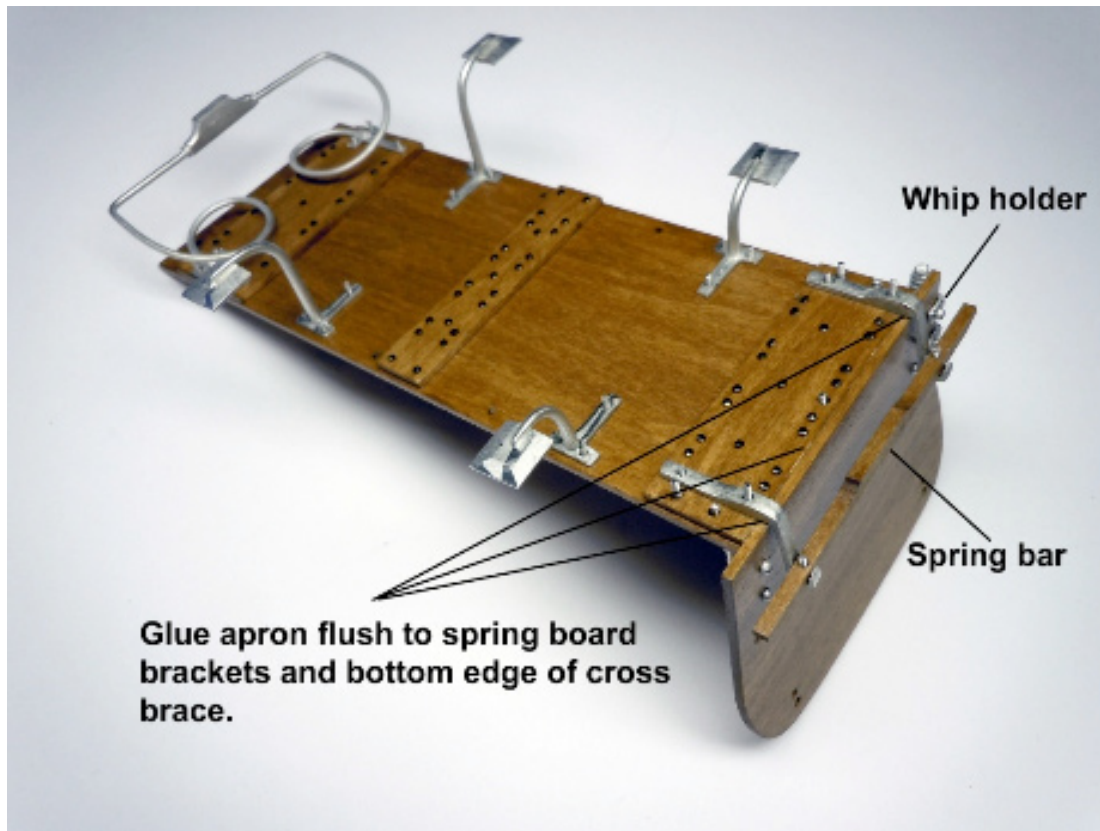


Photo 12

## Platform Cast Parts

### Foot Rest:

1. Dry fit and adjust, straighten and align foot rest flange holes with platform center hole and two rear holes in 90 degree flanges, then prime and paint.
2. Glue two (2) 1/4" round head bolts down through the top of the 90 degree brackets in the front hole positions and add square nuts before adding the painted foot rest.
3. Locate the footrest center hole with a round toothpick and carefully adjust the side flange holes to align with the rear holes in the 90 degree apron bracket. Add and glue 1/4" round bolts and nuts in each location, one at a time.

### Foot Steps:

1. The shorter painted foot steps are located to the front of the apron. Locate and align each with their respective holes using a round toothpick and carefully using Weldwood glue on flange of foot rest, glue in place without gluing the toothpick in the hole. Add and glue 3/16" round bolts and square nuts. Repeat for rear steps and allow glue to set.

### Rear Spring:

1. Carefully drill/ream (8) mounting holes in flanges. Carefully adjust and dry fit flange hole locations in rear platform cross brace using round toothpicks. Paint rear spring when satisfied with dry fit.
2. Once paint is set, glue spring flanges in place aligning holes with toothpicks.
3. Add and glue (8) 1/4" round bolts and square nuts.

## Whip Holder:

1. Clean and drill mounting holes with #55 drill bit. Dry fit to holes (2) in lower right of apron wall (See Photos 12 & 14)
2. Paint whip holder and then glue in place aligning the mounting holes. Add and glue 1/4" round bolts and square nuts. Paint and test fit whip into hole for slip fit into place. Ream hole in holder and/or file whip for slip fit.

## Seat to Platform Assembly

The seat can now be added to the platform using the previously built seat spring bracket assemblies in Photo 5.

1. Dry fit the two (2) seat spring assemblies aligning mounting holes in brackets with mounting holes in underside of seat platform and glue two (2) 1/4" round head bolts down through seat platform surface. Note: the longer arm of the bracket faces forward to enable seat to tilt forward and the square nuts on the springs face inboard. Holding seat spring and seat together carefully add CA glue to inside edge of bracket and underside of seat surface and while still setting true up with building square. (See Photo 13)
2. Once the glue has set repeat for other side and allow glue to set.

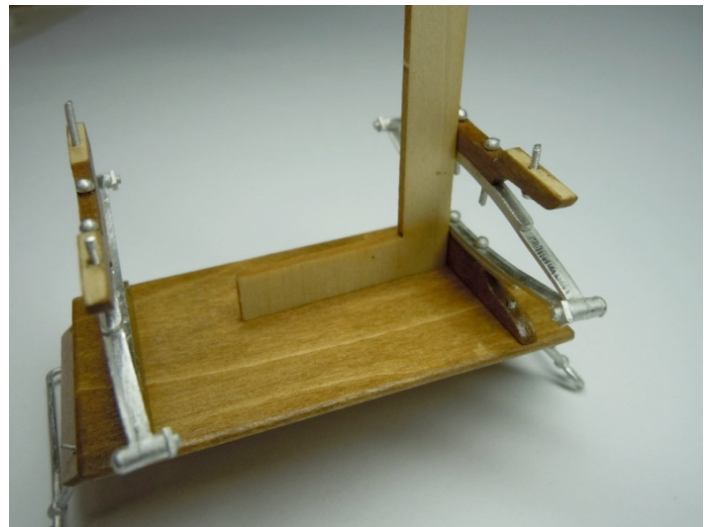
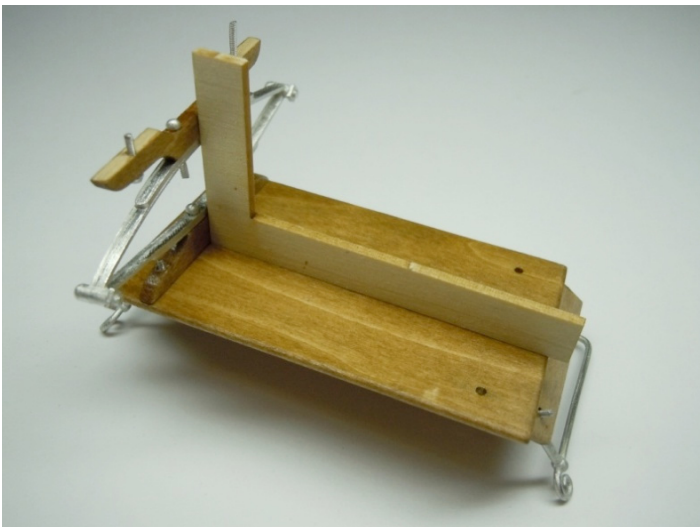


Photo 13

3. Now the seat assembly can be added to the platform by aligning the four (4) mounting holes in the platform with the mounting bolts in the seat assembly and carefully glued with CA added to the inside mating surfaces. True up using the building square just behind the seat before glue sets permanently. (See Photo 14)

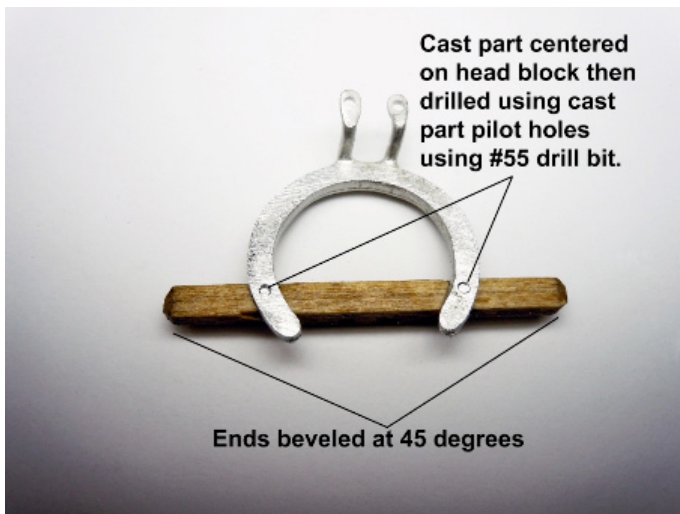


**Photo 14**

4. Once glue has set add small square nuts to front bolts only for extra strength.

#### **Front Axle Carriage Assembly**

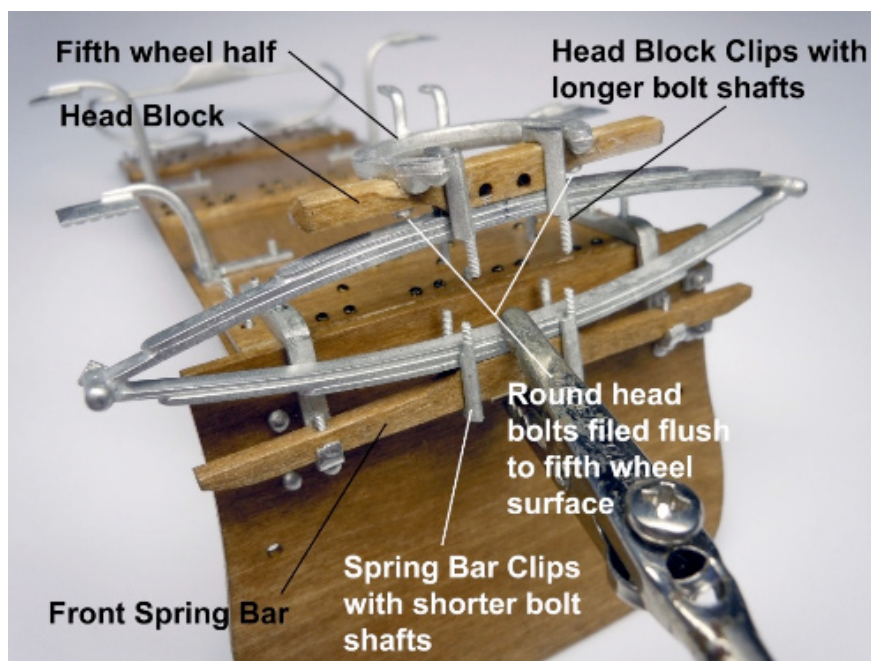
1. Remove the two (2) head block parts with the two holes from WB-1 the 1/16th basswood sheet, align the holes and glue together. Once the glue has set, sand all surfaces to remove any laser residue.
2. Carefully with a sharp #11 blade cut both ends of the head block at a 45 degree angle 1/32" in from the end on the four surfaces resulting in a beveled ends. Stain and spray finish the head block. (See Photo 15)



**Photo 15**



3. Once dry and ready to handle locate the cleaned and painted up upper half of the cast part of the fifth wheel (see Photo 15) and center on the flat bottom surface of the head block. **IMPORTANT** The head block **must be centered** use the center point of the block and the sides of the fifth wheel to verify. Once verified glue the block in place.
4. Drill two holes with a #55 drill bit using the pilot hole positions in the cast part and drill straight down through both the cast fifth wheel and head block. Then glue two painted (2) 3/16" round head bolts into the holes down from the top of the wood head block. Once the glue has set file flush with the flat face surface of the fifth wheel the excess length of the bolt shafts.
5. On the large painted front axle spring mark a center reference line on the top and bottom surfaces.
6. Mark the center of the head block between the two holes with a reference mark.
7. Align the large front axle spring reference mark with that on the head block and glue in place making sure they are center aligned to each other.
8. Locate the two (2) painted head block clips with the flat tops and longer bolt shafts; slip the clips onto the head block and seat against the flat surface with the outside edge of the clip aligned with the point where the spring and curve of the head block meet. (See Photo 16) Cut and paint two (2) clip brackets from the photo etched sheet and glue onto the bolt shafts and then glue two (2) small square P.E. nuts onto the bolt shafts.

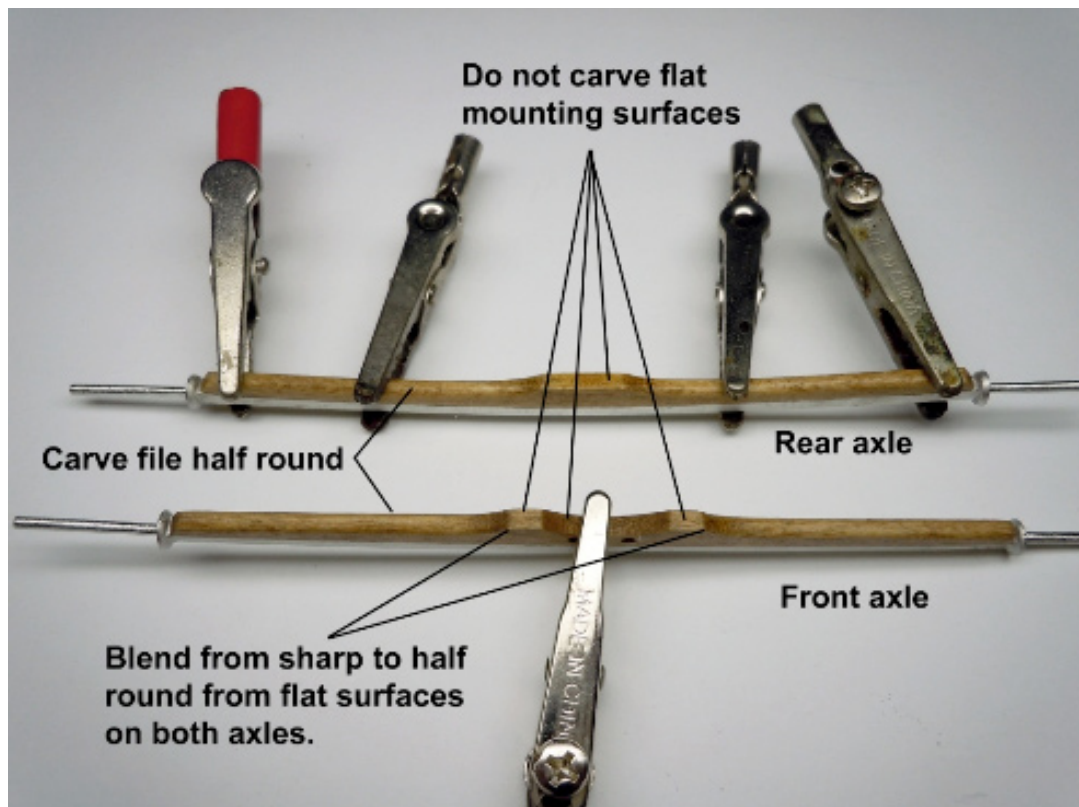


**Photo 16**

9. Once the glue has set thoroughly for step 8 assembly; align the center marks on the spring and spring bar and using a spring clamp glue in place. NOTE: Round head of bolts on end of spring point forward the square nuts to the rear.
10. Locate and add painted spring bar clips with shorter bolt shafts and glue in place aligned with head bolt bolts. Cut and paint two (2) clip brackets from the photo etched sheet and glue onto the bolt shafts and then glue two (2) small square P.E. nuts onto the bolt shafts.
11. Put assembly aside to allow glue to set.

## Front and Rear Axles

1. Remove front and rear wood axle caps from WB-2 the 3.32" basswood sheet and sand all surfaces and stain only. Dry fit and adjust if necessary the cast metal axles for a tight fit to the mating surface of the wood axle caps.
2. Select the front axle cap (with two holes) and glue to the painted cast metal front axle centered between the outboard wheel bearing surfaces to the top surface of the axle. Use small spring clamps to hold tight in place until glue sets. Repeat and glue the rear axle wood cap to the cast metal axle. Let the glue set on both axles.
3. Carefully carve /file and sand smooth the upper surfaces of the front and rear axle caps from the ends in to the flat mounting surfaces. Do not carve the flat mounting surfaces. Use the stain finish as reference while carving to keep all carving even. (See photo17)



**Photo 17**

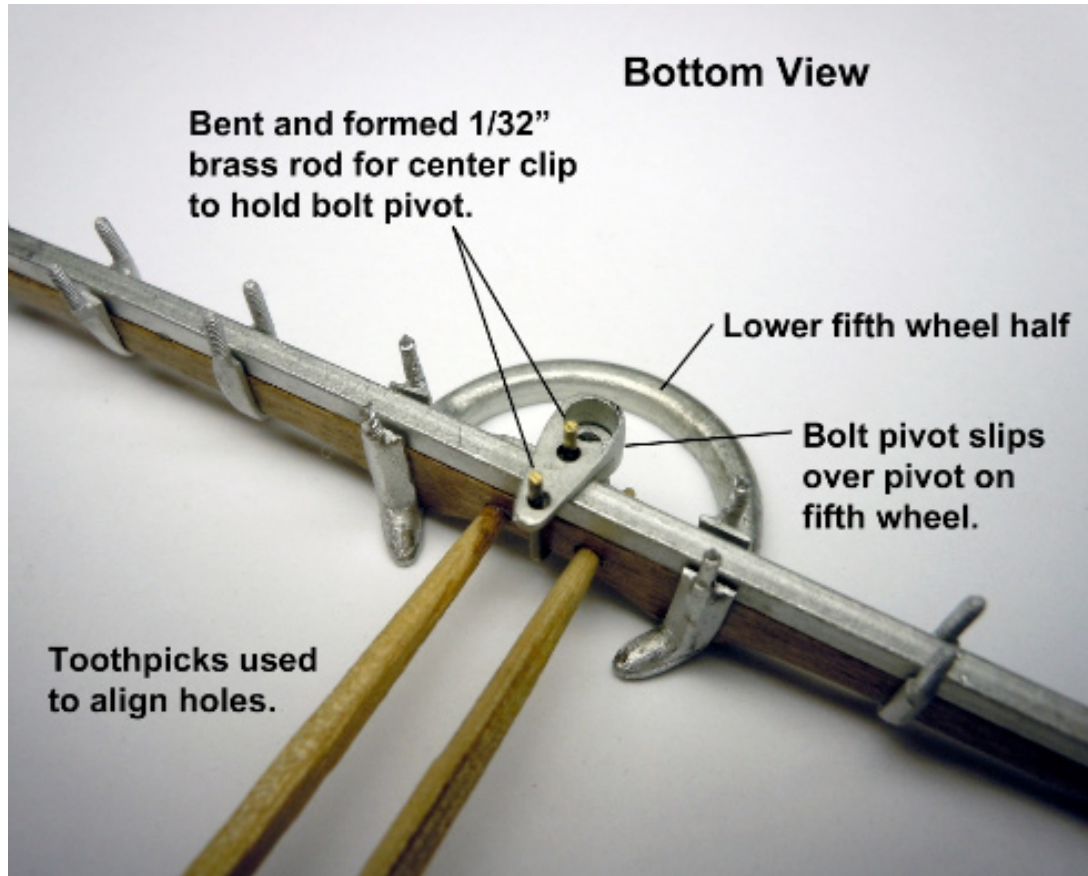
4. Once satisfied with carved and sanded smoothed surfaces re-stain carved areas with a little stain on the tip of a Q-tip. Once the stain is dry then spray Clear Matte Finish on both axle assemblies.

## Front Axle

1. Dry fit the front axle assembly (with the two holes) into the painted cast lower half of the fifth wheel aligning the two holes with the two axle holes and centering the cast part with the two flat mounting surfaces on the axle cap. (See photo 18)
2. When satisfied with the dry fit then glue the axle assembly to the cast fifth wheel half.
3. Cut and paint two (2) axle clip brackets from the photo etched sheet and glue onto the bolt shafts on the fifth wheel half and then glue two (2) small square nuts onto the bolt shafts.
4. Insert/glue two (2) 1/4" painted round head bolts into the two holes in the axle assembly

from the front and then glue two (2) square nuts to the bolt shafts. Note: Align the side of the square nuts to be up and down (vertical). The king pin must fit between them.

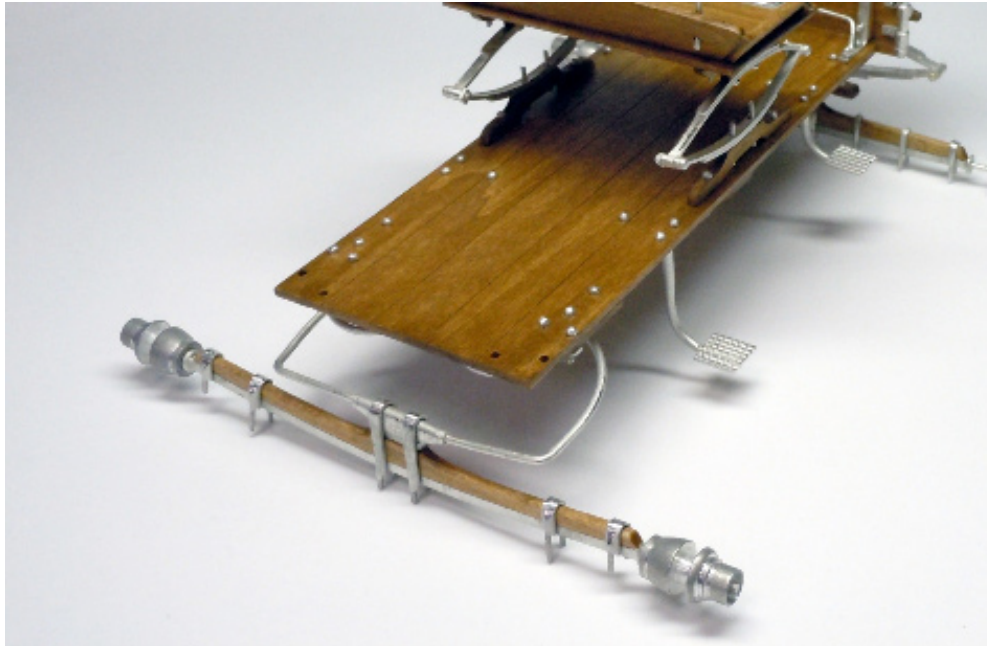
5. Carefully form the center bolt pivot clip using the 1/32" brass rod 1/2" x 1/8" x 1/2" and dry fit to center of front axle and add the cast bolt pivot indexing over the pivot on the fifth wheel. Glue both in place when satisfied with fit and add two (2) small square nuts. (See Photo 18).



**Photo 18**

### **Rear Axle**

1. Invert the platform assembly and rest parallel to work surface with the rear spring mounting surface facing up. Carefully apply glue to flat mounting surface of the painted metal spring and set the wood axle cap flat mating surface in place and align the axle so that it matches the metal surfaces.
2. Fit and glue the two (2) painted long rear axle clips that will hold the rear axle assembly to the rear spring; applying the clips down over the rear spring first. Then apply the painted clip brackets and small square nuts. Allow the assembly glue to set.
3. Once the assembly glue is set, carefully adjust the axle/spring assembly to be parallel to the rear edge of the platform; both in looking down as well as from the rear views.(See Photo 19)



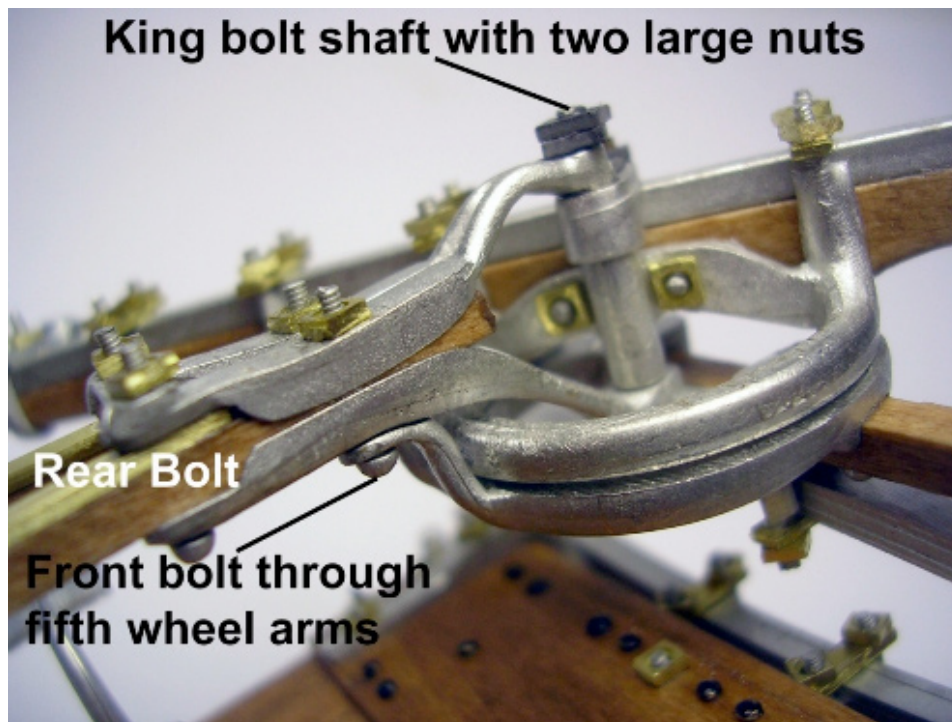
**Photo 19**

### **Reach Assembly**

1. Cut two (2)  $3/32$ " x  $3/32$ " x  $5 - 13/16$ " long basswood strips for the reach arms from supplied basswood strip. Stain and spray with Clear Matte Finish, the two reach arms.
2. Remove two (2) reach arm metal plates from the brass photo etched sheet then prime and paint with Satin Black one side and all edges.
3. Glue the two (2) reach arm metal plates to the top surface of the wood reach arms with the two holes in the metal plate aligned flush with one end of the wood reach arm leaving about  $1/2$ " of the wood strip exposed at the other end.
4. Once the glue has set on the reach arms then drill holes through the wood arms using #55 drill bit and the holes in the metal plate as guides.
5. Align and glue the painted reach plate to the front end upper surface of the reach arms using the toothpicks into the rear holes on each arm of the reach plate to match the hole in the reach arm. Carefully use spring clamp to hold until glue sets. Once glue is set carefully drill the two front holes through the reach arms using the holes in the reach plate arms as guides with the #55 drill bit. NOTE: These holes must be drilled vertically through the wood reach arm.
6. With the platform assembly inverted and the platform parallel to the work surface; set the axle assembly fifth wheel half onto the other half of the fifth wheel and hold in place with two alligator spring clips.
7. Carefully feed the reach arms with reach plate down through the center of the fifth wheel halves and align the two holes in the plate with the two holes in the head block and insert and glue two (2)  $3/8$ " round head bolts into holes through the head block and reach plate. NOTE: The reach arms can be temporarily clamped to rear axle to aid with assembly.
8. The reach plate pivot should touch and align with the fifth wheel pivot hole, carefully adjust to touch and align if necessary then insert the  $3/4$ " long king bolt into reach plate hole and up through the fifth wheel pivot and hold the king bolt shaft in place with a small alligator spring clamp so it does not fall back out of holes.



9. Add two (2) small square nuts to the 3/8" bolt shafts making sure to orient the side of the nuts vertically on either side of the king bolt round head.
10. Dry fit reach brace carefully to the reach arms (remove clamps holding arms to rear axle) and onto the king bolt (tape king bolt head to hold in place when alligator spring clamp is removed) and reach arms aligning all the holes. The reach brace arms with pivot hole may have to be carefully bent to align the hole onto the king bolt shaft. Once satisfied with dry fit use spring clamp to hold in place and glue reach brace to reach arms. At the same time add two (2) large square nuts to the shaft of the king bolt. NOTE: Add glue to only the top large square nut to allow axle to turn freely. Let the glue joints set before next step. (see Photo 20)
11. Once glue has set ream the rear reach plate and brace arm holes with #55 drill bit and insert/glue two (2) 3/8" painted round head bolts into rear holes and add two (2) small square nuts onto bolt shafts.
12. Now ream the front holes and note: adjust and align the holes of the two small arms that come off the upper fifth wheel half to those in the reach arm. Add two (2) 3/8" painted round head bolts down through the fifth wheel arms and add two (2) small square nuts and glue in place. (See photo 20)



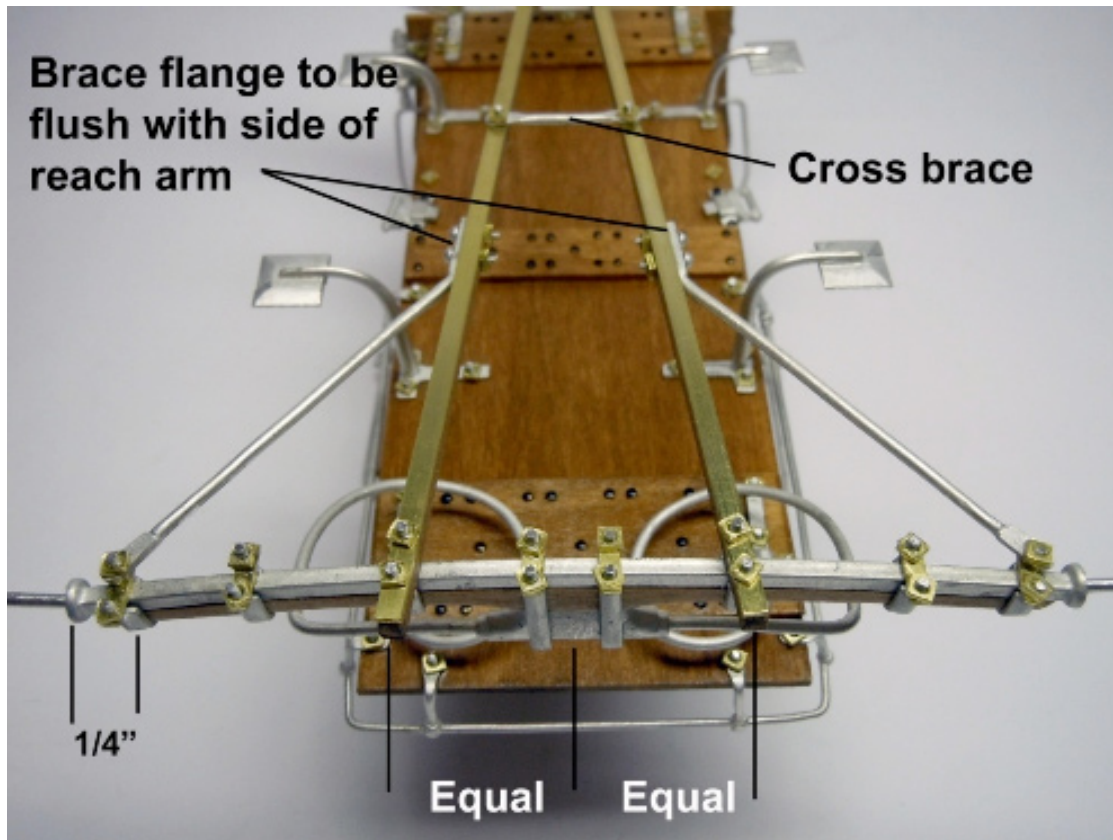
**Photo 20**

13. Move down to the holes in the center of the reach arms and align painted cross brace holes with holes in reach arm. Insert/glue two (2) 3/16" painted round head bolts into holes and add two (2) small square nuts. Allow glue to set for cross brace joints. (See photo 21)

#### **Reach to Rear Axle**

1. Locate the two (2) painted rear axle clips with the longer bolt shafts and slip down over the rear axle and index into the two reach arm holes on each arm. Then carefully slip two (2) painted clip brackets in place over the axle clip shafts. Slight tension should hold them in place.

2. Carefully center the reach arms equally from the center of the rear axle. Once centered glue clips and brackets in place and add four (4) small square nuts to clip shafts.
3. Locate the two (2) short rear axle clips at the wheel end of the axle 1/4" on center of the clip from the wheel bearing surface on the cast metal axle and add two (2) clip brackets and glue in place. Do not add small square nuts yet.
4. Locate and add the two (2) painted reach to rear axle braces. Slip the brace end with one hole over the front axle clip shafts and adjust the ends with the two holes to mate flush with the reach arms. Check to make sure the axle is still parallel with the end of the platform when looking down.
5. With axle parallel and brace flanges flush to the reach arms mark and drill holes using #55 drill bit through reach arm. Select one brace first, insert/glue two (2) 3/16" painted round head bolts and small square nuts. Then repeat for the second brace. Now add all the small square nuts to the small axle clips with brace ends in place.
6. Locate the last two (2) rear axle clips and center them between the reach arm clip and the axle end clip then glue in place while adding the clip brackets and small square nuts. (See Photo 21)

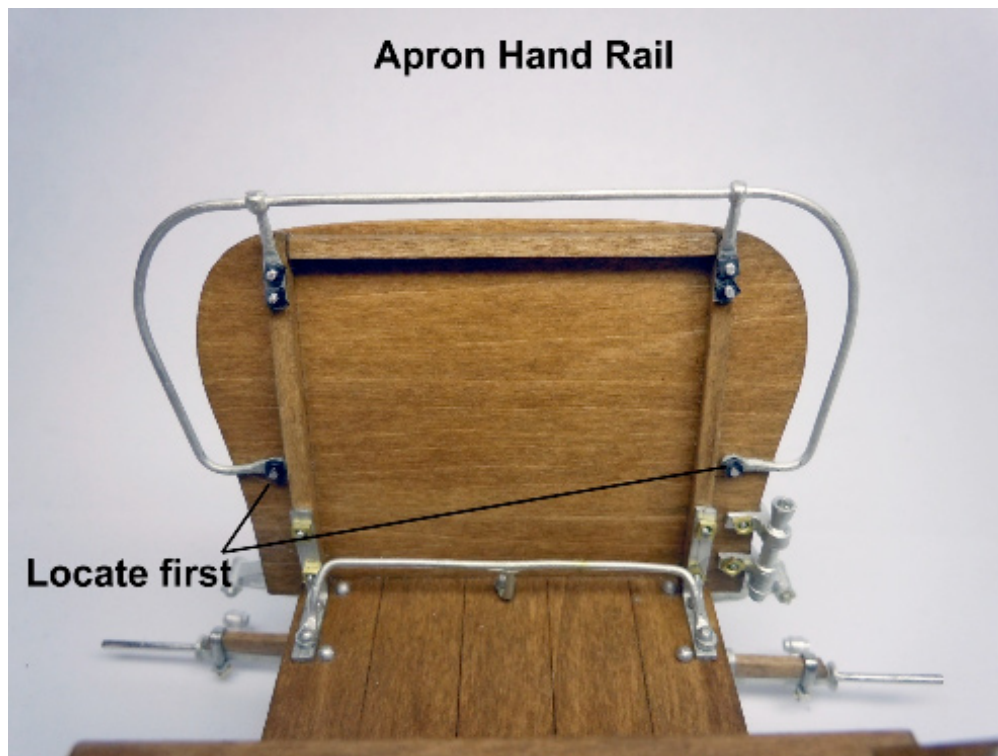


**Photo 21**

### **Luggage Rail, Apron and Seat Rail**

1. These parts are very delicate castings to achieve accurate scale and will require careful and delicate handling. All should be cleaned, dry fitted, adjusted prior to painting. Some may have become distorted in shipping and handling requiring delicate adjustment. Truing up can be accomplished by gently rolling rails with finger on a flat wood surface.

2. With the platform assembly still inverted fit and adjust luggage rail so that all flange holes align with their mounting holes on the underside of the platform. Index the front flange on the bolt shaft of the rear seat mounting bracket and clamp with small alligator spring clamps. Then adjust and add toothpicks to index the corner and end flanges and holes. This step may require the use of small needle nose pliers to adjust rail posts or flanges for alignment. Once satisfied with fit; prime and paint and then re-fit and glue in place using four (4) 3/16" round bolts and small square nuts. Just add/glue two (2) small square nuts to the rear seat spring bracket bolts with rail flange in place. Allow glue to completely set and true up rails to edges of platform. (See photo 23)
3. Now with the platform assembly setting upright resting on the reach arms; dry fit the apron rail and seat rail after cleaning and adjusting then prime and paint both.
4. The apron hand rail requires two (2) 3/16" and four (4) 3/8" painted round head bolts and six (6) small square nuts. Index/glue the two end flanges with 3/16" bolts into apron holes next to the formers and add square nuts. Let the glue set. Note: Insert all bolts from front surface of the apron.
5. Align the hand rail flanges with the four (4) holes and add 3/8" round head bolts with square nuts and glue in place. (See Photo 22) Ream holes with a #55 drill bit if necessary.



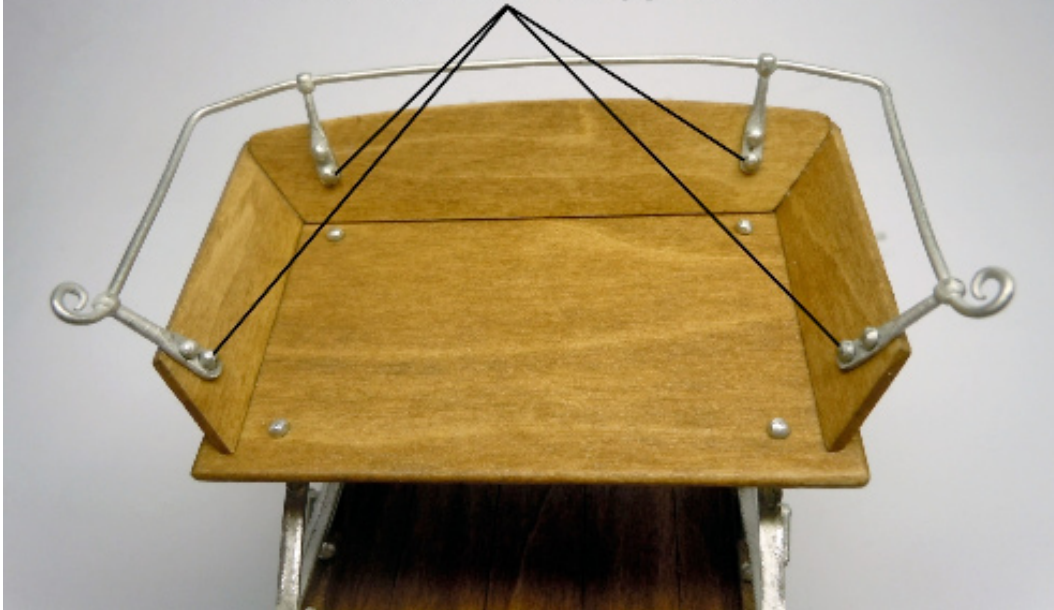
**Photo 22**

6. Dry fit the seat rail and adjust as needed so that rail flanges align with the holes in the inside surfaces of the seat walls with the lower holes on the rail flanges. Once satisfied with dry fit prime and paint seat rail.
7. Index four (4) 3/16" painted round head bolts into the lower holes glue and add small square nuts to bolt shafts. If necessary adjust post alignment before glue sets.
8. Once glue is dry; drill holes with #55 drill bit using the upper flange holes as guide, holes through the side walls. Insert/glue four (4) 3/16" round head bolts and square nuts and glue in place. (See Photo 23)



## Seat Rail

Locate and glue lower bolts first  
then drill and add upper bolts.



**Photo 23**

9. Here is an overall view of all rails in place.(See Photo 24)



**All rails in place.**

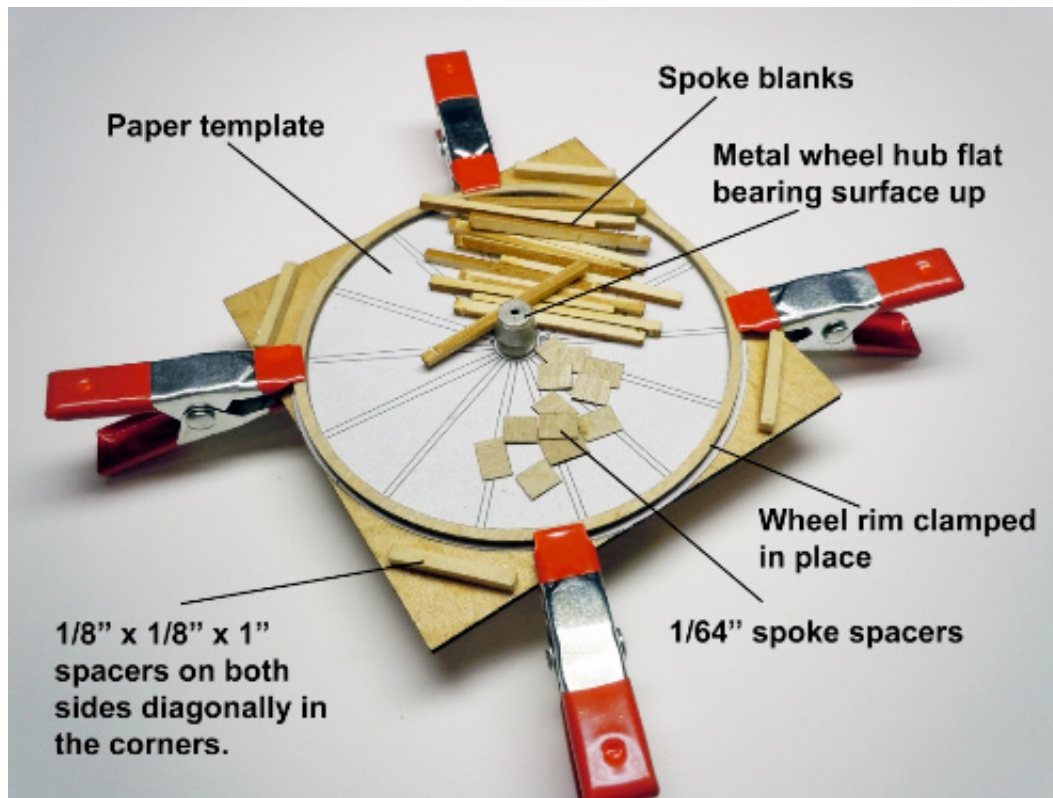
**Photo 24**

10. At this point touch with paint up any bolts, nuts or components and set assembly aside.



## Wheel Assembly

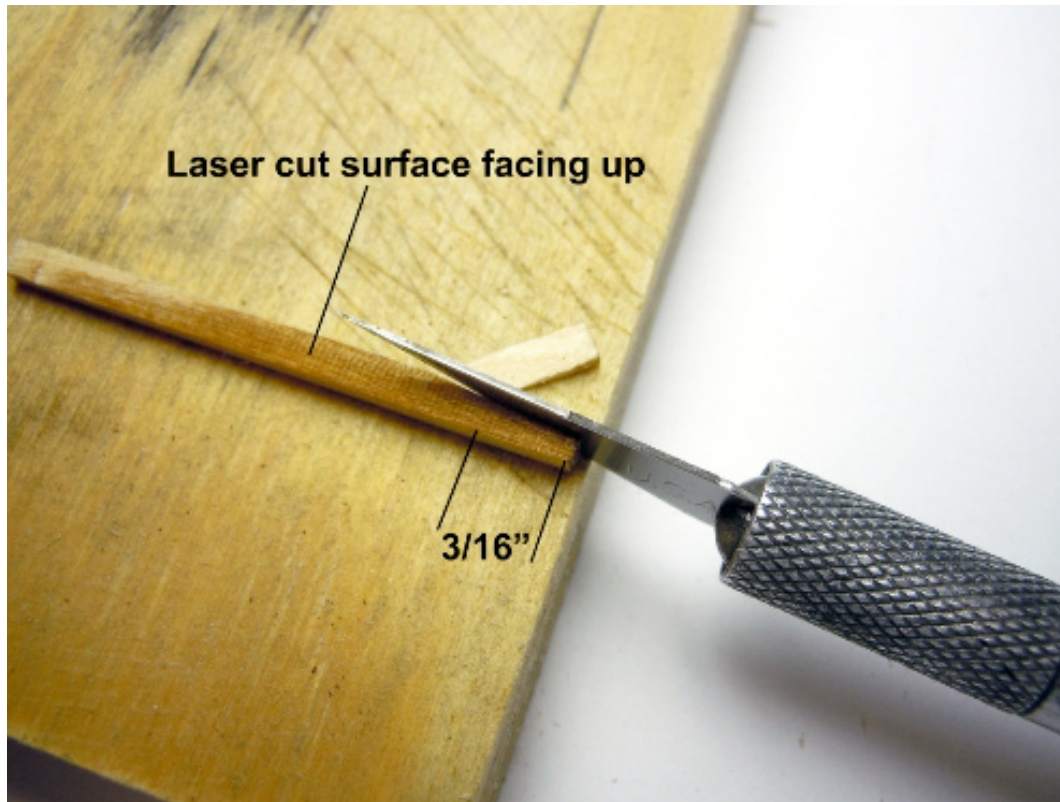
1. Remove the four (4) plywood wheel rims from the 3/32" plywood sheet WD-3 by cutting the tabs with a #11 Xacto knife. The larger diameter rims are for the rear wheels; the smaller diameter the front wheels.
2. Sand and clean both the inside and outside surfaces of all the rims to remove the burnt char residue from the laser cutting. The char has an adverse effect with most adhesives resulting in weak glue joints. Tip: Use a small course needle file after the initial sanding while filing the wheel rim on a scrap wood surface to file the inside surface where the spokes will be glued. Once clean of char then stain only and allow the rims to dry.
3. Cut the large rear wheel paper template from the provided template sheet. Carefully cut out the center hub hole and place on the previously built wheel assembly jig with the 1/8" x 1/8" x 1 inch strips glued diagonally in the four corners. Insert and test fit the metal wheel hub into the paper template hole while also placing the wheel hub into the jig hole and check for the wheel hub to be concentric with the circular reference line.
4. Using double sided tape, spray glue, or glue stick the paper template with the spoke locations visible to the plywood wheel assembly jig.
5. Locate the large plywood rim onto the paper template and align the rim with the drawing of the rim perimeter and use four (4) spring clamps to hold the rim firmly in place. (See Photo 25). Insert painted (Satin Dark Tan) wheel hub with flat axle bearing surface facing up in the wheel assembly jig center hole.



**Photo 25**

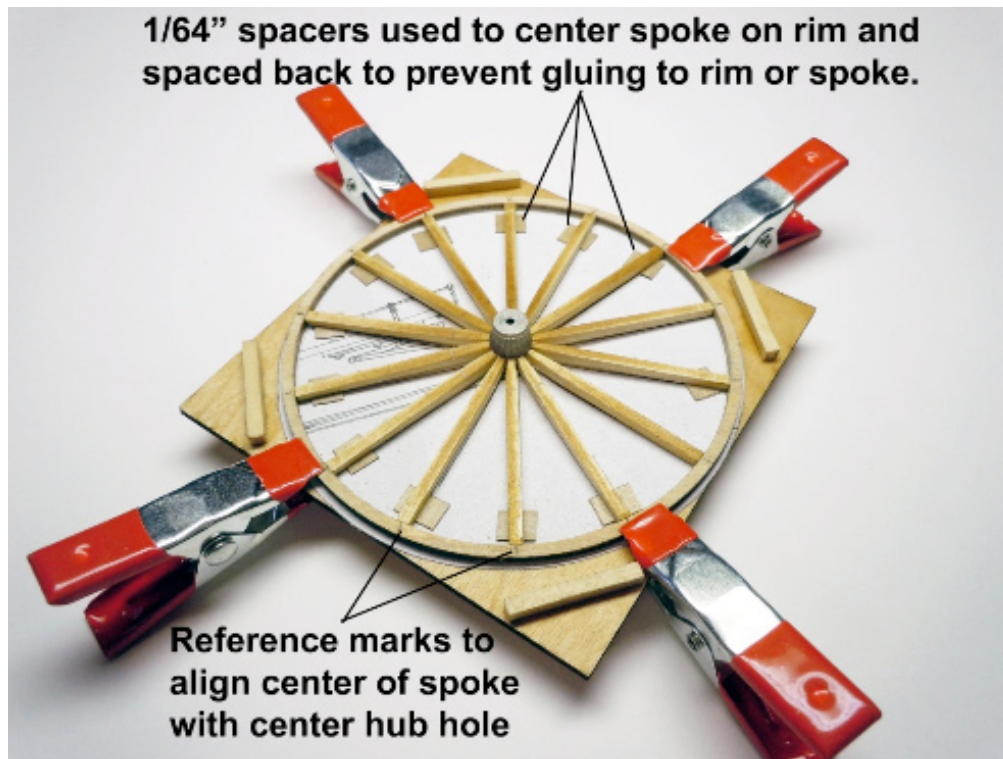
6. Remove fourteen (14) of the long spokes from WB-2 the 3/32" basswood sheet by cutting the retaining tabs on the edges of the spokes.
7. Identify the wider end of the spokes and mark lightly with a pencil a reference line 3/16"

down from the end on all 14 spokes. With the laser cut surface up and a sharp #11 Xacto blade trim each end using the  $\frac{3}{16}$ " reference mark leaving about  $\frac{1}{16}$ " wood surface in the center and trim excess ( $\frac{1}{64}$ " off each side; then sand smooth and then stain all the spokes and allow to dry. (See Photo 26)



**Photo 26**

8. Using a pencil lightly mark on the plywood wheel rim the center of each spoke location for reference.
9. Remove the spoke spacer shims from WB-4 the  $\frac{1}{64}$ " plywood sheet and place one under the spoke at the wheel rim end of the spoke about  $\frac{1}{16}$ " from the rim to avoid being glued to the spoke during assembly.
10. Using Weldwood glue on the end of a round toothpick dab a drop of glue on each end of the spoke and then insert the spoke at a slight angle into the hub first and the other end aligned to the spoke center reference mark and press the spoke end against the inside of the rim making sure the hub end is aligned with the hub center axle hole. Adjust as needed with tweezers and remove any excess glue at either end of the spoke. Since this is the first spoke allow the glue to set before adding the rest of the spokes to avoid shifting.
11. Once the first spoke glue has set a little; quickly and carefully glue the remaining spokes in place using the rim spoke center location marks and justify the equal spacing around the hub before the glue completely sets.
12. Put the assembly jig aside to allow the glue to set with the rim clamps in place and all the spokes in their proper position. To further assure a good strong joint add drops of CA glue carefully around the joint where the cast wheel hub and spokes meet. CAUTION: Be careful not to glue the wheel hub to the assembly jig by adding too much CA glue. Allow the CA glue to set completely before removing the clamps holding the rim to the assembly jig. (See Photo 27)



**Photo 27**

13. While waiting for the gluing operations (Step 12) to set; sand and clean the remaining rims and spokes for each remaining wheel.
14. Once the CA glue has completely set, remove the clamps from the wheel rim and set the wheel aside. Clamp the second wheel rim in place and repeat Steps 6 -12 for the second large wheel.
15. Repeat Steps 3-5 using the front wheel rim sizes. Justify (equalize) the smaller rim size with the lines on the paper template to make sure it is centered relative to the hub.
16. Repeat Steps 6-12 using the shorter spokes.
17. Once all the wheels are assembled and all glue joints firmly set it is time to carefully hand carve the spokes to their final shape using a new sharp #11 Xacto blade. This next carving step should be done slowly, carefully and cautiously being sensitive to the direction and hardness of the wood grain in each spoke. When completed all the spokes should have the same light airy feeling and be as close as possible to identical.
18. With the new sharp #11 Xacto blade proceed to carefully trim starting at the 3/16" mark on the spoke a tapered cut down the spoke to the rim using the stain color as reference for the trim cut. (See Photo 28). I found it easier to hold the rim with my left hand using my fingers gripping equally around the wheel rim and holding the wheel in my hand against my chest. I trimmed all the left side of the spoke first; then cut the right side with the blade protruding up through the spokes. At the rim the trimmed angle cuts should be about 1/6 the width, or about 1/64" of the top surface of the spoke. When both sides of the spoke are cut the result at the rim should be a small half extended octagon shape. (See Photo 28) The eventual desired shape is to be a tapering oval from the hub to the rim.

Once one side of the wheel has all the spokes trim cut then do the other side. Once all the cuts are completed then carefully using a small needle file round off and smooth the spoke



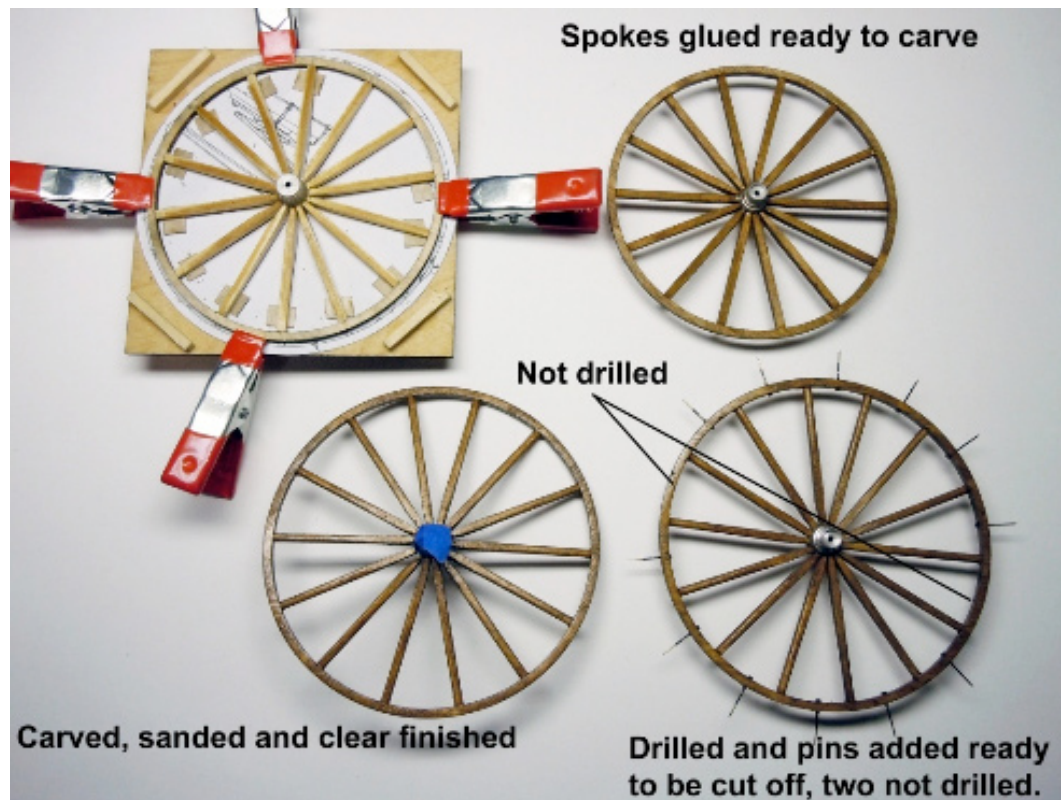
to its final oval shape. All edges of the spokes from the oval cross section at the rim to the rectangular cross section at the hub should be slightly rounded; no sharp edges only varying radii.



**Photo 28**

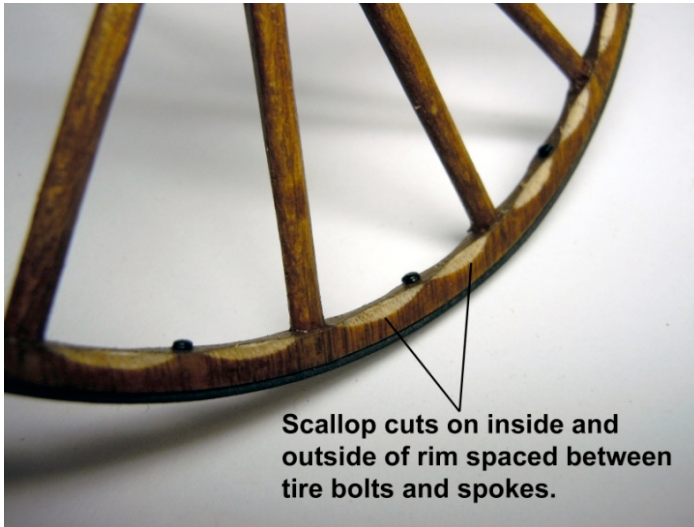
19. Stain the filed and sanded smoothed wheel and spokes making sure the upper part of the spoke adjacent to the wheel hub gets stained as well as the painted hub. The Dark Tan paint works as a base coat color for the stain to match the spokes. You may have to use a small brush to get into the tight areas. Wipe off excess stain and allow to dry completely. Repeat Steps 18 & 19 for all wheels.
20. Using the 1/32" (#67) drill bit in a pin vise, drill holes through the rim centered between the spokes and down from the outside centered on the flat surface of the wheel rim where the tire will be located. Note: Do not drill two locations directly opposite each other; these will have the cast rim joining plates added in the center. (See Photo 29)



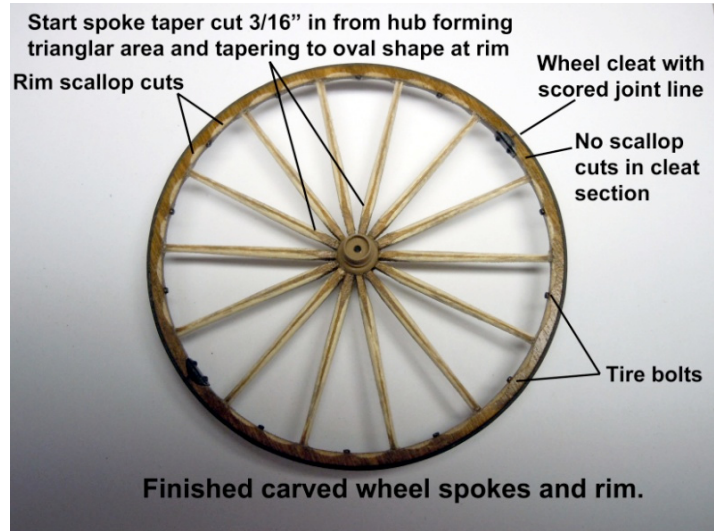


**Photo 29**

21. Insert painted black #8 pins (tire bolts) in the rim holes from the inside of the wheel; twelve (12) in total and CA glue pins in place; cut and file the pin shafts flush with the outside wheel rim surface and file smooth. Repeat Steps 20 & 21 for all wheels. Should a pin loosen during cutting or filing operation just re-glue and allow glue to set.
22. Cut/score a line in the surface to the wheel rim sidewall centered between the spokes with no pin holes using the Xacto blade and stain. This represents the butt joint of the two rim halves. Now add two (2) painted rim joining cleats (cast parts) to all four wheels centered on the scored joint line. (See Photo 31)
23. Remove from WB-5 1/32" gasket material sheet the four (4) tires and carefully glue in place on all four wheels and mate the ends flush with a butt joint. Care must be taken to not cut too short with a resulting gap in the tire.
24. Once all wheel tires have set; a final detail must be hand carved using care and judgment to both the inside and outside edges of the plywood wheel rims. Again with a sharp #11 Xacto blade remove a slight arcing (scallop) cut between the painted black wheel bolt (pin) heads and the spokes. There are no cuts in the section with the rim cleats. (See Photos 30 & 31) This rim detail was typical for buggy wheels of the period to help reduce the buildup of mud on the rim surface. When cutting with a sharp #11 blade start at a spoke or bolt head and slowly cut using a slicing action with the blade and remove just a little at a time and be sensitive to the grain hardness of the plywood and use the stain as a reference gauge.

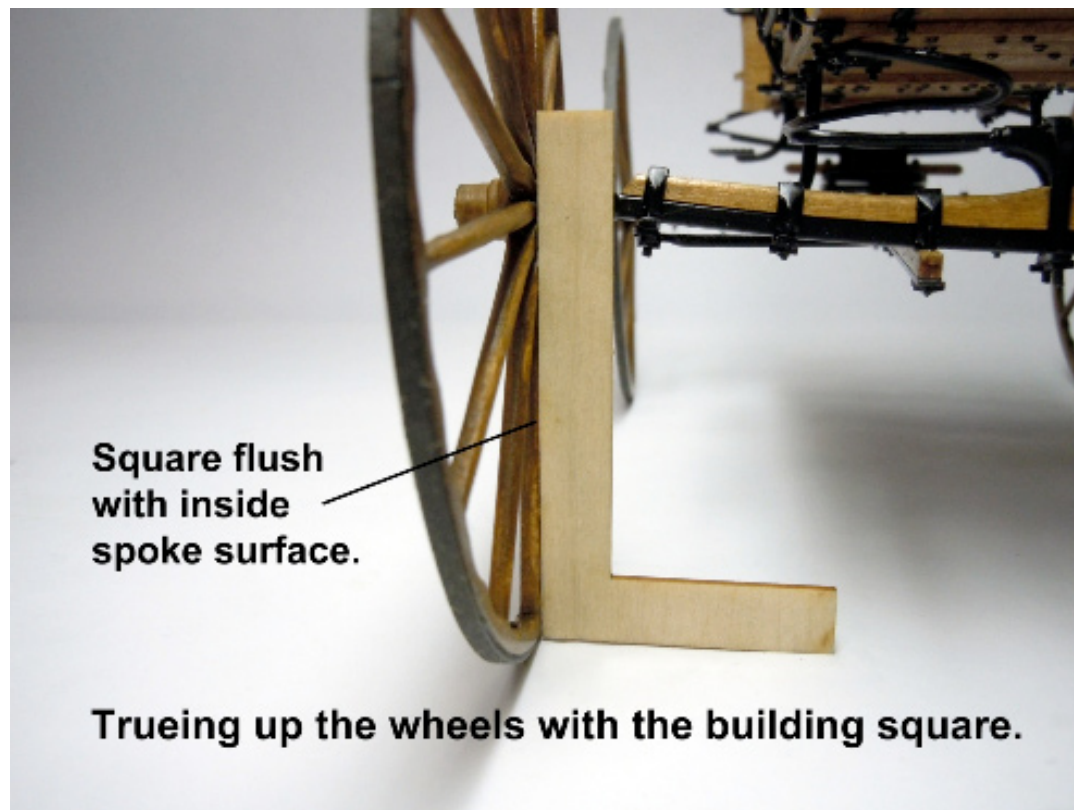


**Photo 30**



**Photo 31**

25. Once all wheel rims have been cut and stained; spray both sides of wheels with Clear Matte Finish and allow to thoroughly dry.
26. Slip all four wheels on their respective axle locations and the wheels should turn freely. Locate and remove from WB – 5 eight (8) large square nuts and index/glue two together to represent the original wheel nut thickness. Index four of the thick square nuts and slip onto ends of axle shafts to hold wheel in place and carefully glue. CAUTION: DO NOT glue the hub to the axle shaft. Wheel should turn freely on the axle shaft when the glue is set on the large square nuts.
27. Lastly, while looking down on the buckboard and carefully adjust wheels to be parallel to the platform sides by holding the wheel rim and bending slightly in the direction needed. Then looking from the rear carefully adjust the camber (slight angle of the wheel) of all the wheels angled in at the bottom of the wheels. Adjust the front and rear wheels for proper camber; using the building square touching the inside edge of a spoke (See Photo 32). The dish in the wheels formed a truss structure and the angle enables the spokes to be perpendicular to the ground for greater wheel strength.



**Photo 32**

28. Check the entire model for any nuts or bolt shafts that need trimming or filing flat and touch up with Satin Black paint as needed.
29. Place the painted whip into the whip holder and the model is complete; sit back and admire.



## Reference Photos









### Scale Models of Legendary Wood Ships

#### HMS BOUNTY'S LAUNCH

Length 17-1/4"  
Height 14-3/4"  
Beam 5-3/8"  
Scale (1:16)

No. MS1850



#### DAPPER TOM

Length 24"  
Height 18"  
Scale 5/32" = 1 ft.

No. MS2003



#### NEW BEDFORD WHALEBOAT, C. 1850-1870

Length 24"  
Height 4-5/8"  
Scale 3/4" = 1 ft. (1:16)

No. MS2033



#### HARRIET LANE

Length 19-1/2"  
Height 9-1/2"  
Scale 3/32" = 1 ft.

No. MS2010



#### PINNACE

Length 11-3/4"  
Width 2-1/2"  
Scale 1/2" = 1 ft. (1:16)

No. MS1458



#### 18TH CENTURY LONGBOAT

Length 11-3/4",  
Scale 1/4" = 1 ft.

No. MS1457



#### PHANTOM, NEW YORK PILOT BOAT

Length 13-1/2"  
Height 13-1/2"  
Scale 1/8" = 1 ft.

No. MS2027



#### FLYING FISH

Length 36"  
Height 22-1/2"  
Scale 1/8" = 1 ft. (1:96)

No. MS2018

#### MAYFLOWER, 1620

Length 22"  
Height 17"  
Scale 5/32" = 1 ft.

No. MS2020



#### FAIR AMERICAN

Length 26-1/2"  
Height 22"  
Scale 1/4" = 1 ft. (1:48)

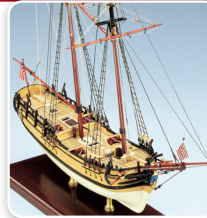
No. MS2015



#### SULTANA

Length 17"  
Height 15" Scale 3/16" = 1 ft. (1:64)

No. MS2016



**RATTLESNAKE, PRIVATEER, 1780**  
Length 28"  
Height 18"  
Scale 3/16" = 1 ft. (1:64)

No. MS2028



**GUNBOAT PHILADELPHIA**  
New from Bob Crane, designer of USN Picket Boat No. 1

No. MS2263



**WILLIE L. BENNETT, SKIPJACK**  
Length 24"  
Height 16"  
Scale 3/8" = 1 ft. (1:32)

No. MS2032



**USS ESSEX**  
Length 27"  
Height 8"  
Scale 5/32" = 1 ft. (1:76.8)

No. MS2041



**USS CONSTITUTION, 1797**  
Length 48"  
Height 32"/Width 16"  
Scale 5/32" = 1 ft. (1:76.8)

No. MS2040

#### BENJAMIN W. LATHAM

Length 33"  
Height 27"  
Scale 1/4" = 1 ft. (1:48)

No. MS2109



#### PRIDE OF BALTIMORE II

Length 32"  
Height 22-1/2"  
Scale 3/16" = 1 ft. (1:64)

No. MS2120



**BLUENOSE, CANADIAN FISHING SCHOONER**  
Length 32"  
Height 26-1/2"  
Scale 3/16" = 1 ft. (1:64)

No. MS2130



**CHARLES W. MORGAN, WHALING BARK**  
Length 25"  
Scale 3/16" = 1 ft. (1:64)

No. MS2140



**EMMA C. BERRY LOBSTER SMACK**  
Length 26-3/8"  
Height 28-1/2"  
Scale 3/8" = 1 ft (1:32)

No. MS2150



**ARMED VIRGINIA SLOOP**  
Length 31"/Height 18"/Width 8-1/4"  
Scale 1/4" = 1 ft. (1:48)

No. MS2160



**GLAD TIDINGS, PINKY SCHOONER**  
Length 29-1/2"  
Height 23" /Scale 1/2" = 1 ft. (1:24)

No. MS2180



**CHAPERON, STERNWHEELER**  
Length 34-1/2"/Beam 7-1/2"/Height 12"/ Scale (1:48)

No. MS2190

#### NIAGARA, U.S. BRIG 1813

Length 36-1/2"  
Height 24-1/2"  
Scale (1:64)

No. MS2240



#### SYREN, US BRIG 1803

Length 33"  
Height 27"/ Scale 3/16" = 1 ft (1:64)

No. MS2260



#### U.S.N. PICKET BOAT NO. 1, 1864

Length 22-1/2"  
Width 5"/Scale 1:24 (1/2" = 1 foot)

No. MS2261



#### CONFEDERACY

Length 35"  
Height 8-1/2"  
Scale 3/16" = 1 ft

No. MS2262





**CIVIL WAR RUCKER AMBULANCE**

Length 8" · Width 4-1/2" · Height 6-1/8" · Scale 1:16  
**No. MS4017**



**WHITWORTH 12-POUNDER**

Length 10" · Width 4" · Height 3-1/4" · Scale 1:16 Weight 1 lb. 4 oz.  
**No. MS4001**



**NAPOLEON CANNON, 12-POUNDER**

Length 10" · Width 4" · Height 3-1/4" · Scale 1:16 · Weight 1 lb. 4 oz.  
**No. MS4003**



**PARROTT RIFLE**

Length 8" · Width 4-1/2" · Height 3-1/3" · Scale 1:16 · Weight 1 lb. 4 oz.  
**No. MS4008**



**CAISSON, AMMUNITION CARRIAGE**

Length 8-1/4" · Width 4" · Height 3-1/2" · Scale 1:16 · Weight 1 lb.  
**No. MS4009**



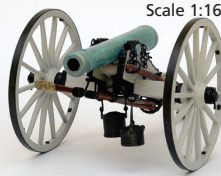
**CIVIL WAR LIMBER**

Length 10" · Width 4" · Height 3-1/4" · Scale 1:16 · Weight 1 lb.  
**No. MS4002**



**JAMES CANNON, 6-POUNDER**

Length 8-1/4" · Width 4-1/2" · Height 4" · Scale 1:16 · Weight 1 lb. 4 oz.  
**No. MS4007**



**GATLING GUN**

Length 7-7/8" · Width 3-3/4" · Height 3-1/4" · Scale 1:16  
**No. MS4010**



**ORDNANCE RIFLE**

Length 8" · Width 3-3/4" · Height 3-1/4" · Scale 1:16  
**No. MS4013**



**BATTERY FORGE**

Length 7-7/8" · Width 3-3/4" · Height 3-1/4" · Scale 1:16  
**No. MS4012**



**MOUNTAIN HOWITZER**

Length 5" · Width 3-1/2" · Height 2-3/4" · Scale 1:16  
**No. MS4014**



**DOUBLE BARREL CANNON**

Length 7-3/4" · Width 3-3/4" · Height 3-3/4" · Scale 1:16  
**No. MS4015**



**COFFEE WAGON**

Length 5-7/8" · Width 4-1/2" · Height 4-1/2" · Scale 1:16  
**No. MS4016**



**NAPOLEON CANNON, 12-POUNDER BRASS BARREL SIGNATURE SERIES**

Length 8-1/4" · Width 4" · Height 3-1/2" · Scale 1:16  
**No. MS4003SS**



**CIVIL WAR LIMBER SIGNATURE SERIES**

Length 10" · Width 4" · Height 3-1/4" · Scale 1:16  
**No. MS4002SS**



**18th Century Naval Cannon Models**

**32-POUNDER CARRONADE**

L 8-1/4" W 4-1/2" H 3-1/2" · Scale 1:24  
**No. MS4004**

**NAVAL DECK CANNON**

L 8-1/4" W 5-1/4" H 3" · Scale 1:24  
**No. MS4005**

**18TH CENTURY SEA MORTAR**

L 4" W 3" H 2-3/4" · Scale 1:16  
**No. MS4011**



**1:12 Scale Models of Horse-drawn Vehicles** Turn of the century wagon model kits that are second to none.

**BUCKBOARD WAGON**

Length 9-3/4" · Height 5-1/4" · Scale (1:12)  
**No. MS6004**



**CONCORD STAGECOACH**

Length 13-3/4" · Height 8-3/4" · Scale (1:12)  
**No. MS6001**



**CONESTOGA WAGON**

Length 19" · Height 9" · Width 6" · Scale (1:12)  
**No. MS6002**



**DOCTOR'S BUGGY**

Length 5-1/2" · Height 5" · Width 8" · Scale (1:12)  
**No. MS6003**



**1:16 Scale Models of Vintage Aircraft**

The ultimate collection of renowned aircraft model kits.



**NIEUPORT 28**  
Wingspan 20" · Fuselage 15-3/4" · Scale 1:16 · Weight: 1.9 lb.  
**No. MA1002**



**THE WRIGHT FLYER, 1903**  
Wingspan 30" · Length 15" · Scale 1:16  
**No. MA1020**



**SOPWITH CAMEL F.1, 1917**  
Wingspan 21" · Fuselage 14-1/16" · Scale 1:16 (3/4" = 1 ft.)  
**No. MA1030**

**CURTISS JN4D 'JENNY'**  
Wingspan 32-1/2" · Fuselage Length 20-1/2" · Scale 1:16  
**No. MA1010**



**ALBATROS D.VA, RED BARON'S AIRPLANE'**  
Wingspan 22-1/2" · Fuselage 18-1/4" · Scale 1:16 · Weight 1 lb. 14 oz.  
**No. MA1001**

