

Mosquito Bomber MK IX



The plane was nicknamed the wooden wonder. Built almost entirely from wood the De Havilland Mosquito was not only one of the fastest planes of WWII but also one of the most stealth planes of its time. Originally conceived as an unarmed fast bomber, the Mosquito was adapted to roles including low to medium-altitude daytime tactical bomber, high-altitude night bomber, pathfinder, day or night fighter, fighter-bomber, intruder, maritime strike aircraft, and fast photo-reconnaissance aircraft. The Mosquito was first flown in November of 1940 with production beginning a year later; the aircraft remained in production till 1950. The main bulk of the 7781 units were built in the UK with Canada and Australia contributed over 1300 units. Removal of front line service began in the late 1950's with many being scrapped, some were sold off to the private sector. One notable private sector operator was Spartan Air Services, operating 10 converted Mosquitos for aerial mapping. Today very few Mosquitos have survived and up until recently there have been non airworthy. That all changed in 2012 when a New Zealand company restored one to flying condition. To date there is now three airworthy units.

The markings included in this kit are from LR503. The aircraft was a MK IX built in the UK around October of 1943. The significance of this aircraft is that it holds the record for most combat operations flown by an Allied bomber in the Second World War. Unfortunately the aircraft crashed while doing high a speed flyby while on a victory tour in Calgary Alberta just days after the war ended killing both pilot and its navigator.

MK IX Mosquito Specifications

Crew	2
Length	44' 6"
Wingspan	54' 2"
Power	2 x Rolls-Royce Merlin 72 V12's rated at 1,680 hp @3,000 rpm
Performance	Max speed 408mph
Armament	Bomb load, internal 2000lbs external 1000lbs
Numbers built	55

Mosquito Bomber MK IX



Featuring markings of LR503 "F" for Freddie

Wooden

Semi Scale Model Kit

Easy build sandwich construction

No special tools required

PAINT NOT INCLUDED

1:66 Scale

FOR AGES 8 AND UP
SKILL LEVEL 2
Contains One Model Kit

OSBORN MODEL KITS
www.osbornmodelkits.com



KIT-6048

Building tips:

DO NOT FORCE PARTS. All parts will be a tight fit. If you find a part is too tight give it a bit of a sanding with 220 grit sandpaper. A hobby knife is suggested to cut the pieces from the part tree but most parts will break free easily. 220 grit sandpaper may be used to remove unwanted burn marks. A white glue may be used for assembly if desired. Any black substance that gets on your hands is non toxic and can be removed with soap and water.

Step 1

Fuselage

Slide alignment blocks through alignment holes on part 1 making sure that they are centred. Then stack parts 2L, 2R through to 5L and 5R on to the pins.

Note:

Alignment blocks should have just enough friction to hold parts in place. If needed use sandpaper to remove a bit of thickness.

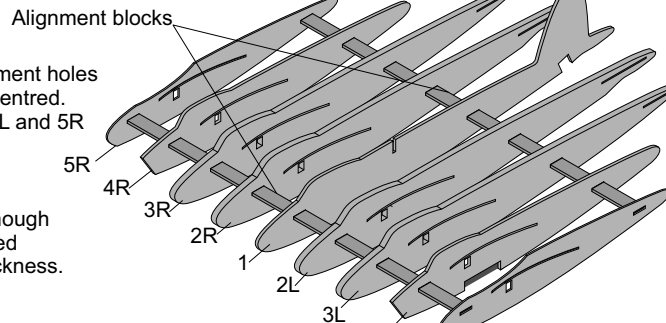

Step 2

Engine nacelles

Slide alignment blocks through alignment holes on part 6 making sure that they are centred. Stack 9R out, part 7R out and 8R out onto the right of part 6 followed by 9R out. Place part 7R in and 8R in onto the left side of part 6 followed by 9R in. Repeat the process to make a left side.

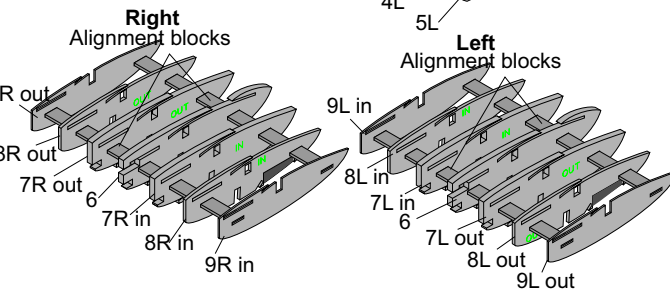

Step 3

Wings and spare assembly

Slide part 10 through the slots on the top of the engine nacelle till the centre of nacelle lines up with the etched line on part 10. Slide part 11 into the square hole on the outer side of the nacelle so that the slot at the end of part 11 interlocks into the slot at the tip of part 10. Stack 7, part 12's on to the end of part 11.

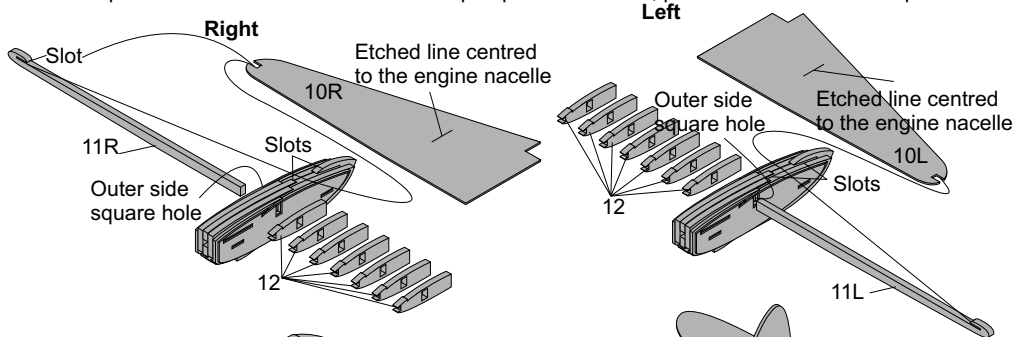

Step 4

Main assembly

Insert the completed wing sections into the slots on the side of the fuselage. Insert parts 13L and 13R into the slots on the tail.

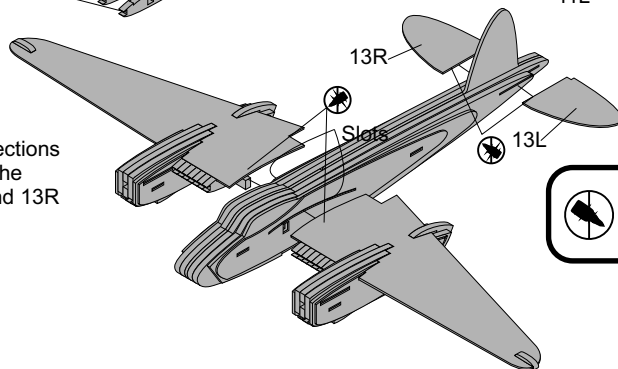

Note:

Parts labelled with this symbol are not to be glued as they will need to be removed to add the decals

Step 5

Exhaust and propellers

Slide part 14 into the front slot on the engine nacelle and centre. Insert the shaft of part 5 into the hole on part 16 and 17 then insert into the front of the engine. Place part 18 into the square hole on top of the fuselage.

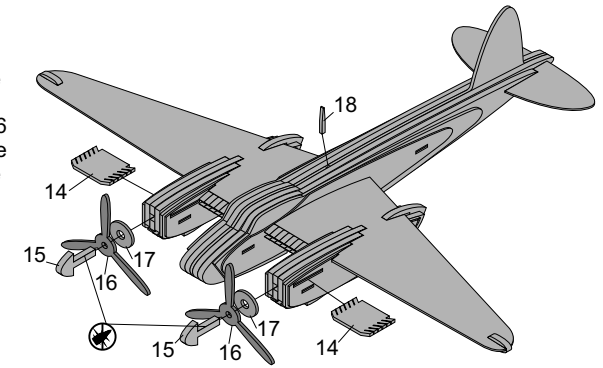

Step 6

Landing gear

Place parts 19 onto the legs of part 21 then sandwich part 20 in the centre of parts 19. Insert parts 22 into the slots on part 21.

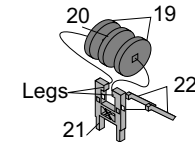

Step 7

Finale assembly

Turn model over and insert part 23 into the slot on the bottom of the tail. Insert the main landing gear into the matching slots on the bottom of the nacelles. Place parts 24 into the long thin slots along side the landing gear. Slide parts 25 into the slots behind landing gear. Parts 26 slide into the thin slots on the bottom of the fuselage.

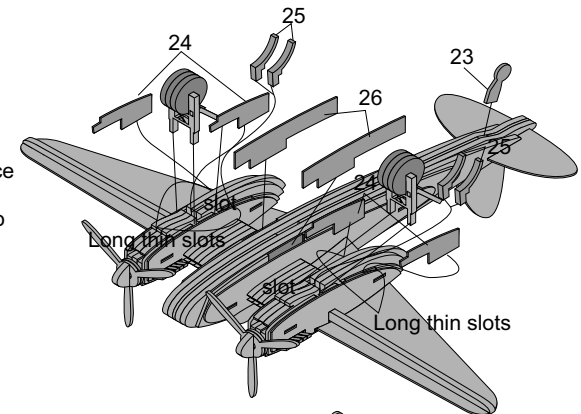

Step 8

Place part 27 into the base to complete stand, place model on stand

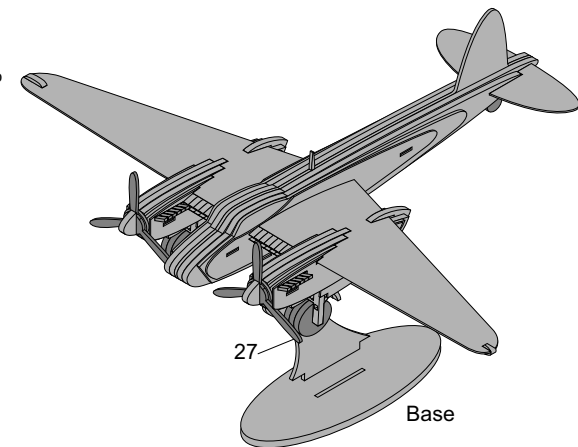

Completed model ready for paint and decals. Please see the separate sheet for paint and decal instructions.



Remove any vinyl that may be covering slots with a utility knife

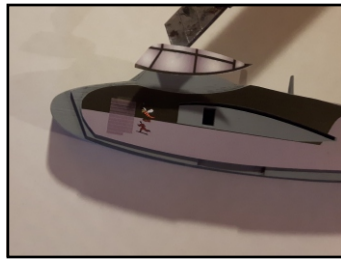

For small decals you may use a small utility knife to remove them from the backing and place in position.

Decals should be placed into position in numerical order. You will need to remove the main and tail wings, propeller assembly, exhaust to apply some of the decals.

Take your time.

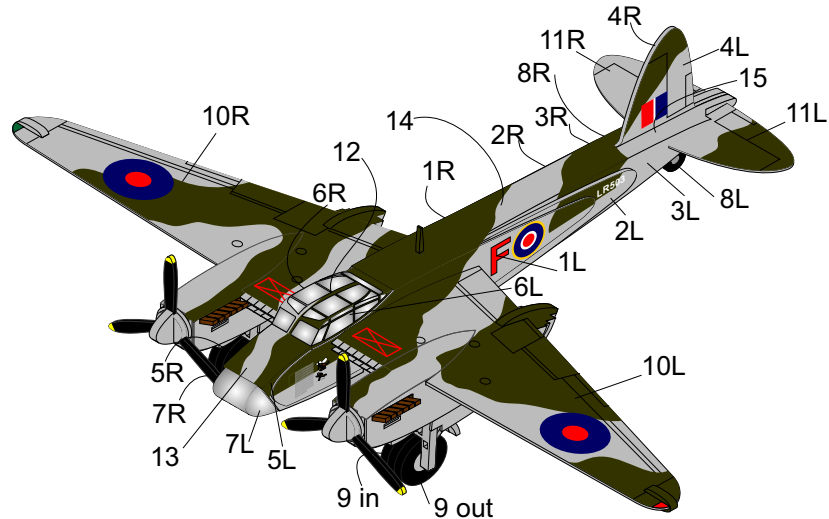
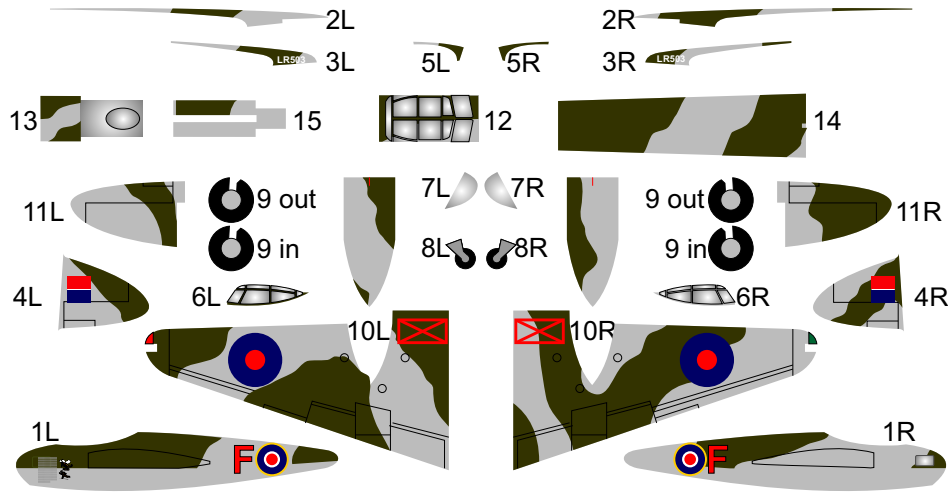

Applying decals

Tools needed to apply decals

Scissors

Utility knife

Make sure your hands are clean before applying decals. Avoid contact with the adhesive as this can cause the decal to lose some of its adhesion. Decals will adhere better to a smooth clean surface so we do recommend painting your model for best results.



Cut out each decal as close to the edge as possible. Only cut out decals as needed.

Note:

Paint entire aircraft gray before applying decals.



For the large decals, remove about a 1/4" of the backing and cut off with scissors.



Place the exposed section on the surface making sure that your decal is properly aligned on the part.



Slowly remove the backing making sure the decal is staying aligned on the surface.

Colour Scheme of Mosquito Bomber MKIX LR503

Suggested colours by Testors Model Paints

- 1 **Dark Ghost Gray 1741**
All under surfaces
Propeller spinners
Outside landing gear doors
Outside bomb bay doors
Wheel fenders
- 2 **Black 1147**
Propeller blades
Wheels
- 3 **Aluminum 1181**
Landing gear
- 4 **Brown 1140**
Exhaust
- 5 **Yellow 1114**
Tips of propeller
- 6 **Interior Green 1715**
Inside of landing gear doors
Inside of bomb bay doors
- 7 **Green Drab 1787**
Touch up for camouflage
Radio Antenna

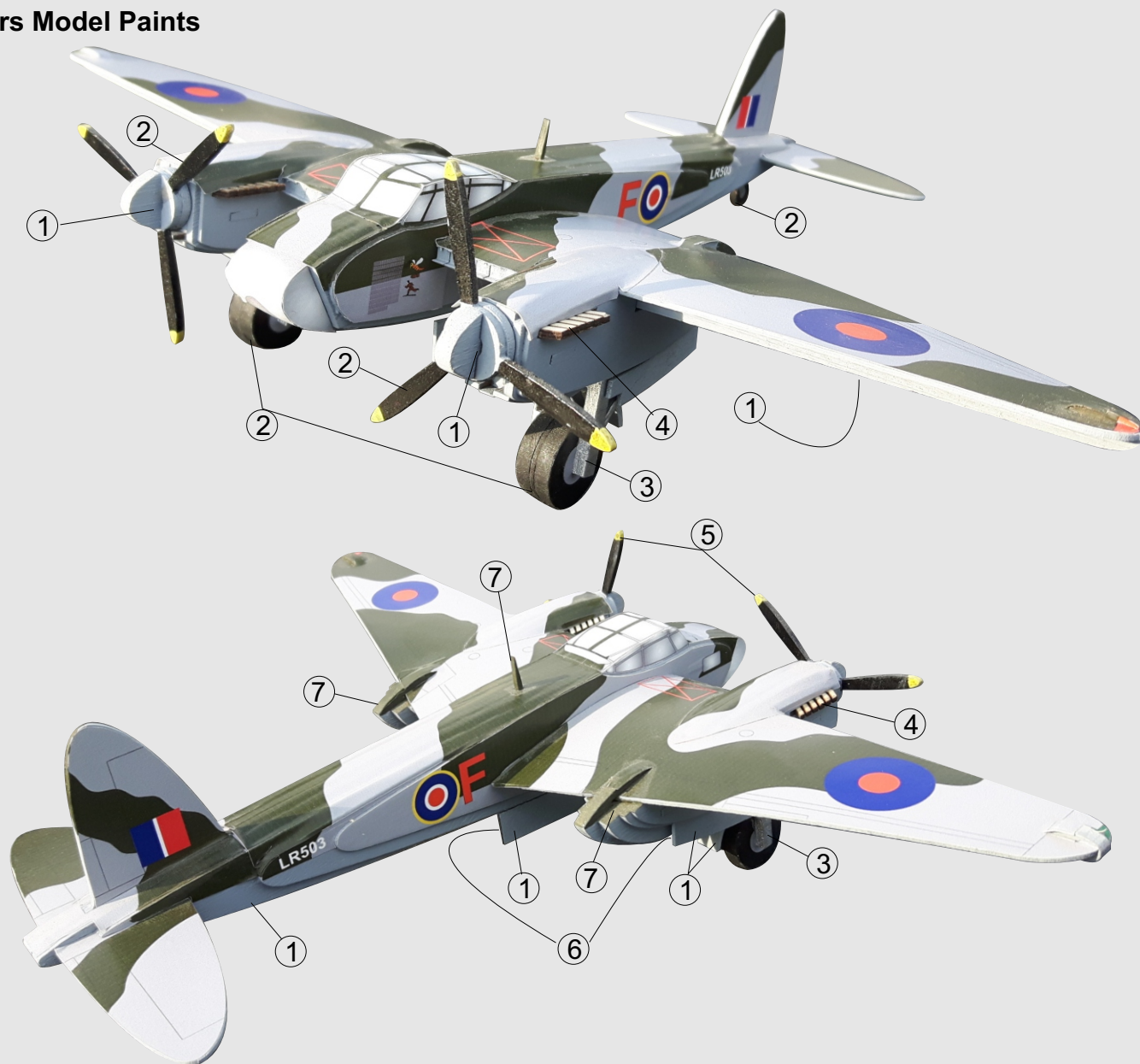

Note:

Model should be painted gray before adding decals.