

Step 1:

Remove the kite from the bag and set aside the Wing Brace Struts and Propeller.

Note: Wing Brace Struts may be packaged inside the Airplane Body.

Step 2:

Rotate the Airplane Body so that it is perpendicular to the Wings. (diagram A)

Step 3:

Hook the Nocks at the ends of the Nose Cross Strut into the holes on the sides of the Airplane Body opening. (diagram B)

Step 4:

Hook the Nock at the end of the Lower Body Strut into the hole at the bottom of the Airplane Body opening. (diagram C)

Step 5:

Position one Wing Brace Strut between the fabric upper and lower wing connector and the pre-installed Wing Brace Strut. Insert one end of the Wing Brace Strut into the fitting at the front of the top wing. Arch the Strut to fit the other end into the fitting at the back of the bottom wing. Repeat with the remaining Wing Brace Struts. (diagram D)

Step 6:

Remove the End Cap from the Center Body Strut and slide the Propeller onto the Strut. Replace the End Cap. (diagram E)

Step 7:

Attach flying line to tow loop on the front of the kite.

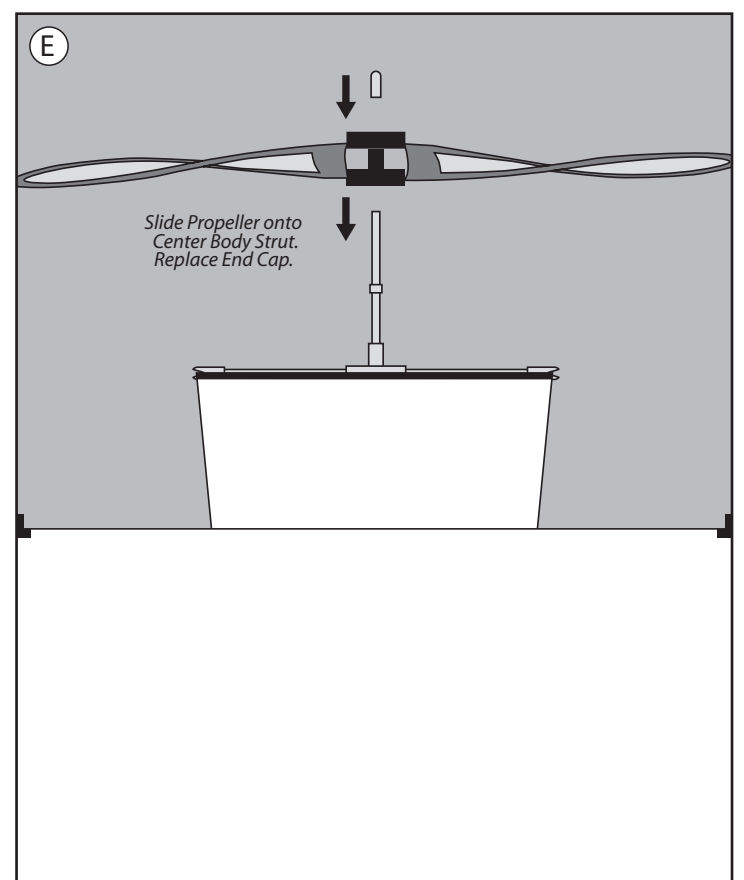
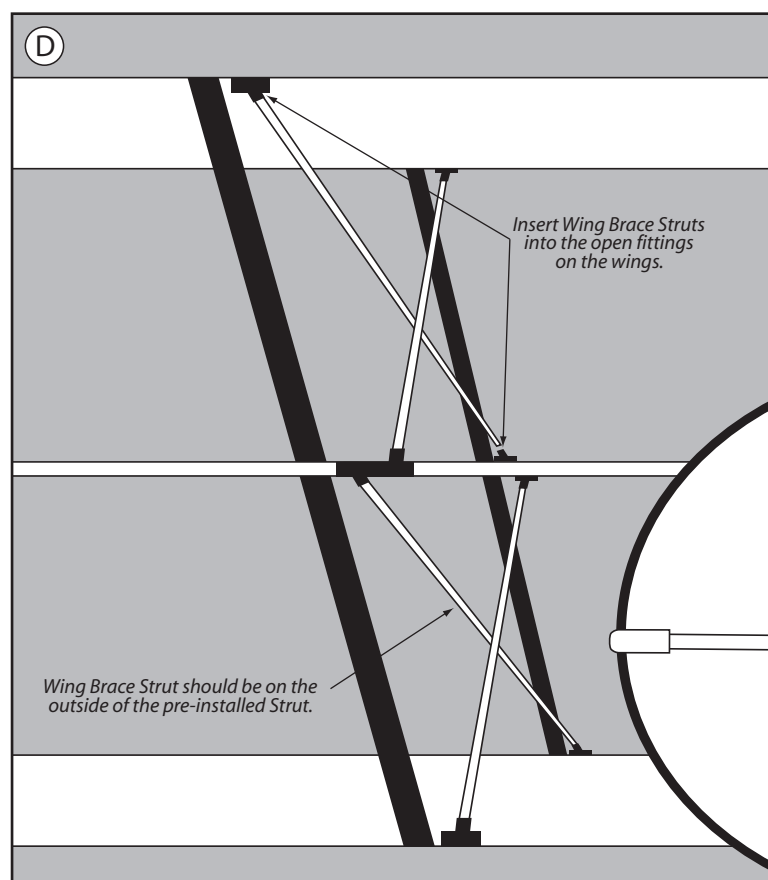
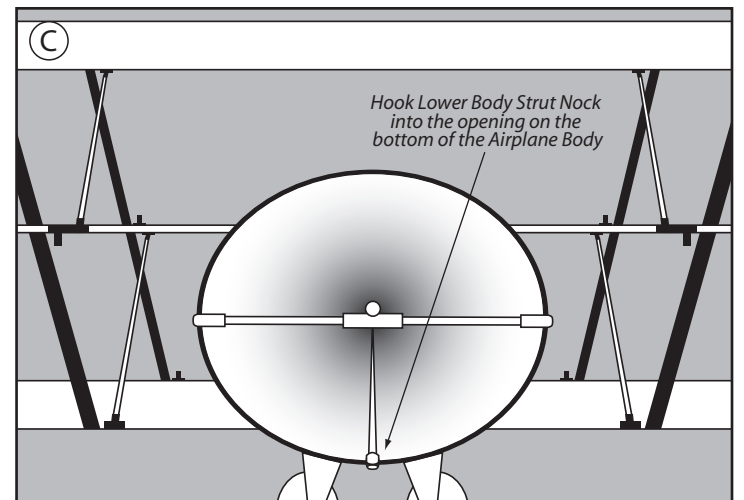
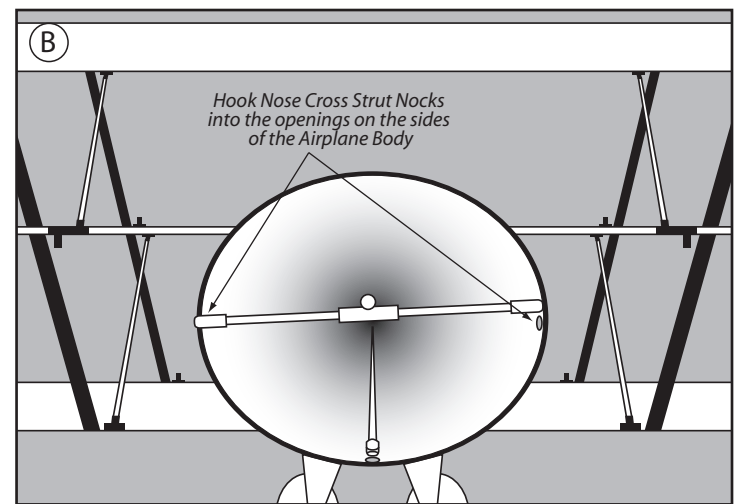
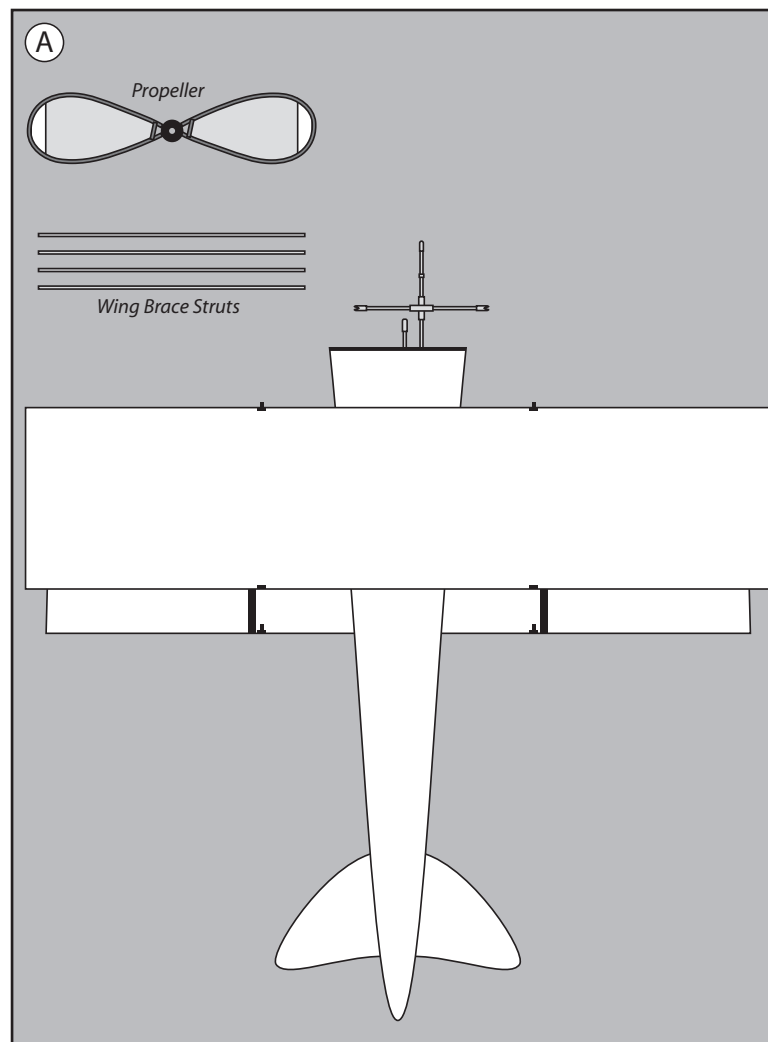

OPTIMUM WIND CONDITIONS FOR TRIPLANE KITE

BEAUFORT SCALE	CALM	LIGHT AIR	LIGHT BREEZE	GENTLE BREEZE	MODERATE BREEZE	FRESH BREEZE	STRONG BREEZE	
WIND [M.P.H.]	0	1 2 3	4 5 6 7	8 9 10 11 12	13 14 15 16 17 18	19 20 21 22 23 24	25 26 27 28 29 30	
				TRIPLANE KITE				