

RTR
READY-TO-RUN

HORIZON
H O B B Y

MINI-B™

1/16 SCALE 2WD BUGGY

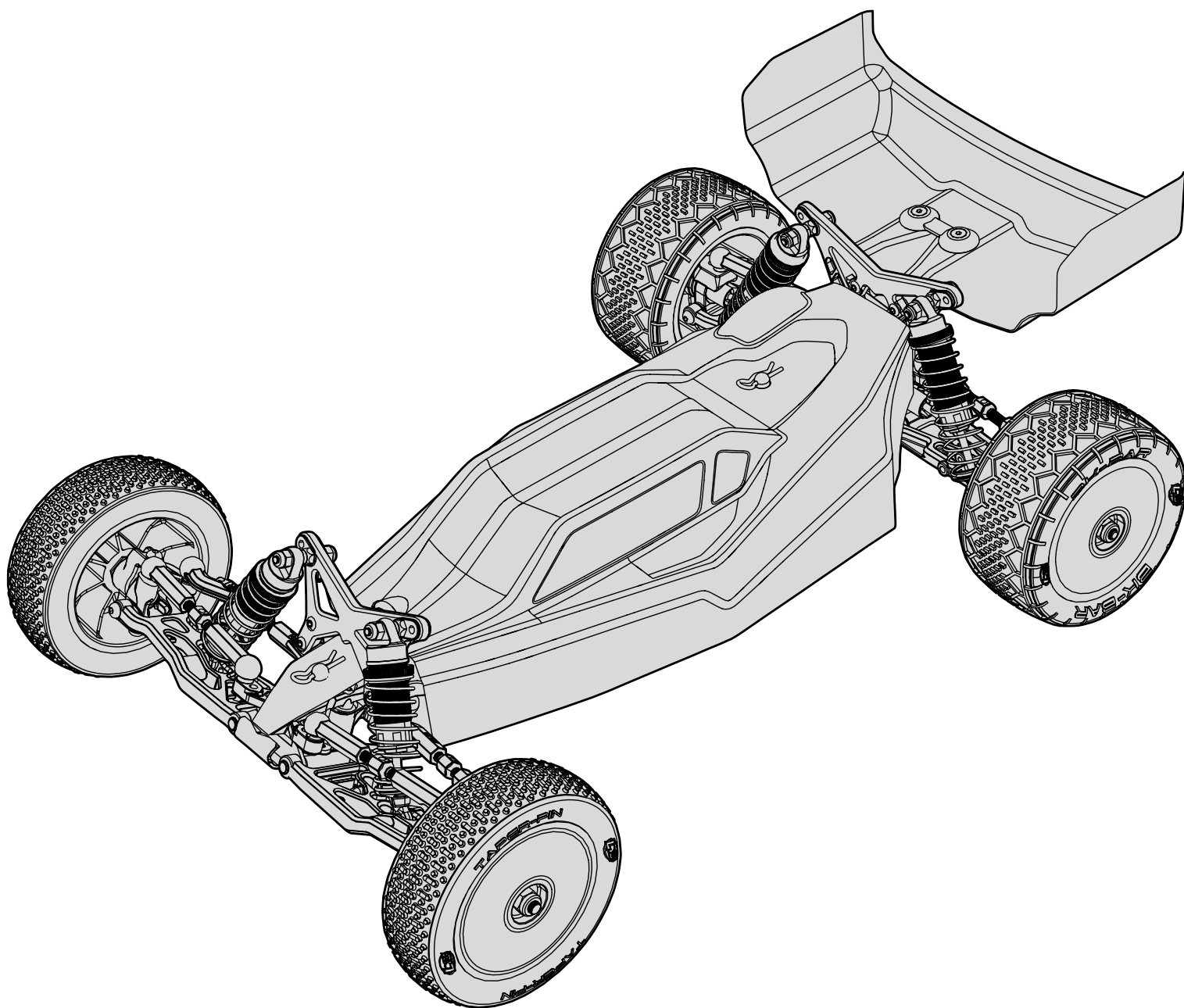

INSTRUCTION MANUAL
BEDIENUNGSANLEITUNG
MANUEL D'UTILISATION
MANUALE DI ISTRUZIONI



Before operating this vehicle, please read all printed materials thoroughly.
Horizon Hobby is not responsible for inadvertent errors in this manual.

NOTICE

All instructions, warranties and other collateral documents are subject to change at the sole discretion of Horizon Hobby, LLC. For up-to-date product literature, visit www.horizonhobby.com or www.towerhobbies.com and click on the support or resources tab for this product.

MEANING OF SPECIAL LANGUAGE

The following terms are used throughout the product literature to indicate various levels of potential harm when operating this product:

WARNING: Procedures, which if not properly followed, create the probability of property damage, collateral damage, and serious injury OR create a high probability of superficial injury.

CAUTION: Procedures, which if not properly followed, create the probability of physical property damage AND a possibility of serious injury.

NOTICE: Procedures, which if not properly followed, create a possibility of physical property damage AND a little or no possibility of injury.

 **WARNING:** Read the ENTIRE instruction manual to become familiar with the features of the product before operating. Failure to operate the product correctly can result in damage to the product, personal property and cause serious injury.

This is a sophisticated hobby product. It must be operated with caution and common sense and requires some basic mechanical ability. Failure to operate this Product in a safe and responsible manner could result in injury or damage to the product or other property. This product is not intended for use by children without direct adult supervision. Do not use with incompatible components or alter this product in any way outside of the instructions provided by Horizon Hobby, LLC. This manual contains instructions for safety, operation and maintenance. It is essential to read and follow all the instructions and warnings in the manual, prior to assembly, setup or use, in order to operate correctly and avoid damage or serious injury.

Age Recommendation: Not for children under 14 years. This is not a toy.

SAFETY PRECAUTIONS AND WARNINGS

- Always keep a safe distance in all directions around your model to avoid collisions or injury. This model is controlled by a radio signal subject to interference from many sources outside your control. Interference can cause momentary loss of control.
- Always operate your model in open spaces away from full-size vehicles, traffic and people.
- Always carefully follow the directions and warnings for this and any optional support equipment (chargers, rechargeable battery packs, etc.).
- Always keep all chemicals, small parts and anything electrical out of the reach of children.
- Always avoid water exposure to all equipment not specifically designed and protected for this purpose. Moisture causes damage to electronics.
- Never place any portion of the model in your mouth as it could cause serious injury or even death.
- Never operate your model with low transmitter batteries.

TABLE OF CONTENTS

REGISTER YOUR LOSI PRODUCT ONLINE	2
COMPONENTS	2
RECOMMENDED ACCESSORIES	2
TOOLS INCLUDED	2
CONTENTS	3
WATER-RESISTANT VEHICLE WITH WATERPROOF ELECTRONICS	3
GENERAL PRECAUTIONS	3
WET CONDITIONS MAINTENANCE	3
QUICK START	3
CHARGING WARNINGS	4
CHARGING THE BATTERY	4
INSTALLING THE BATTERY AND POWERING ON THE VEHICLE	4
TRANSMITTER	5
ASSEMBLING AND DISASSEMBLING THE TRANSMITTER HANDLE	5
INSTALLING THE TRANSMITTER BATTERIES	5
ADJUSTING THE DUAL RATES	5
BINDING	5
CONTROL TEST	6
DRIVING PRECAUTIONS	6
RUN TIME	6
GETTING STARTED	6
OPERATION	6
TUNING, ADJUSTING AND MAINTAINING THE VEHICLE	7
SERVICE/REPAIR	7
SHOCK CLEANING	7
TROUBLESHOOTING GUIDE	8
LIMITED WARRANTY	9
WARRANTY AND SERVICE CONTACT INFORMATION	10
FCC INFORMATION	10
IC INFORMATION	10
EU COMPLIANCE STATEMENT	10
PARTS LISTINGS	36
OPTIONAL PARTS	37
EXPLODED VIEW	38–41

REGISTER YOUR LOSI PRODUCT ONLINE

Register your vehicle now and be the first to find out about the latest option parts, product updates and more. Click on the Support tab at www.LOSI.com and follow the product registration link to stay connected.

COMPONENTS

- Losi® 1/16 Mini-B™ RTR 2WD Buggy
- Horizon® 3-CH 2.4GHz Transmitter (HRZ00001)
- Horizon® ESC/Receiver 2.4GHz: 1/18 (HRZ00002)
- Dynamite® 47T 280 Brushed Motor (DYNS1218)
- Spektrum™ SX107 Micro Metal Gear Servo (SPMSSX107)
- Dynamite® 7.4V 650mAh 2S 20C LiPo Hardcase: EC2 (DYNB65021H2)
- Dynamite® USB 2S LiPo charger (DYN1063)
- 4 AAA batteries (for transmitter)

RECOMMENDED ACCESSORIES

- Soft bristle brush for cleaning
- Startup Tool Set: Metric (DYN2834)
- Thread Lock

TOOLS INCLUDED

- 4-Way Wrench
- 1.5mm Hex 1" Wrench

Use only Dynamite® tools or other high-quality tools. Other tools can cause damage to the small screws and parts used on this model.

CONTENTS

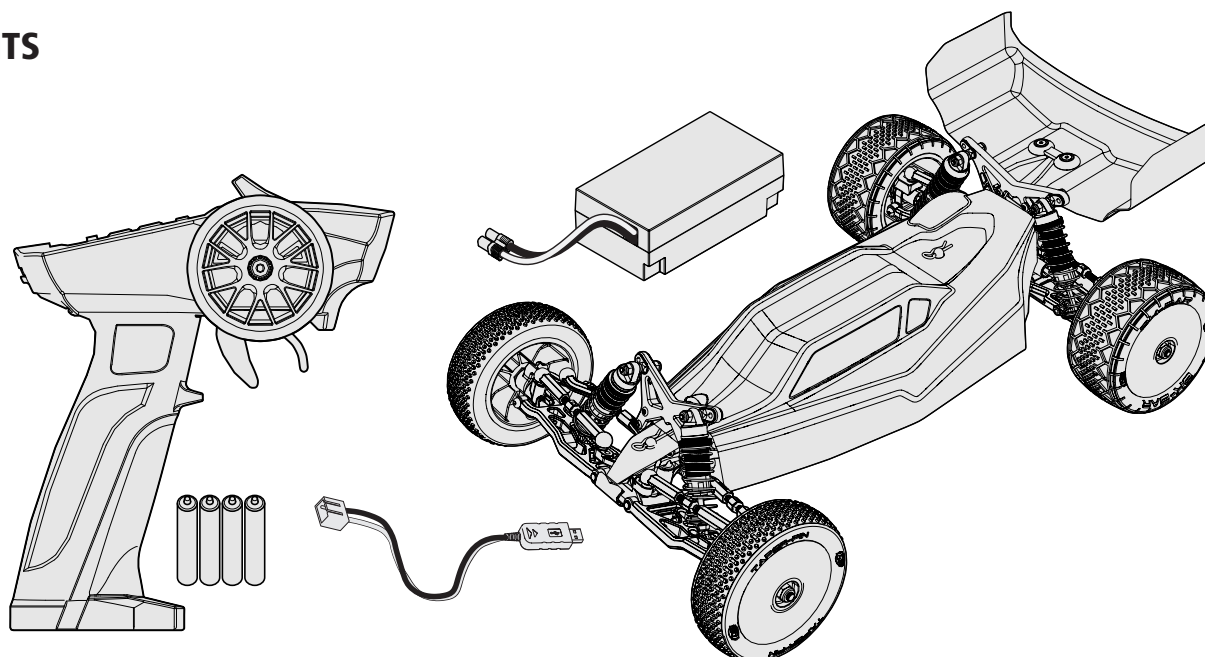

WATER-RESISTANT VEHICLE WITH WATERPROOF ELECTRONICS

Your new Horizon Hobby vehicle has been designed and built with a combination of waterproof and water-resistant components to allow you to operate the product in many “wet conditions,” including puddles, creeks, wet grass, snow and even rain.

While the entire vehicle is highly water-resistant, it is not completely waterproof and your vehicle should NOT be treated like a submarine. The various electronic components used in the vehicle, such as the Electronic Speed Control (ESC), servo(s) and receiver are waterproof, however, most of the mechanical components are water-resistant and should not be submerged.

Metal parts, including the bearings, hinge pins, screws and nuts, as well as the contacts in the electrical cables, will be susceptible to corrosion if additional maintenance is not performed after running in wet conditions. To maximize the long-term performance of your vehicle and to keep the warranty intact, the procedures described in the “Wet Conditions Maintenance” section below must be performed regularly if you choose to run in wet conditions. If you are not willing to perform the additional care and maintenance required, then you should not operate the vehicle in those conditions.

CAUTION: Failure to exercise caution while using this product and complying with the following precautions could result in product malfunction and/or void the warranty.

GENERAL PRECAUTIONS

- Read through the wet conditions maintenance procedures and make sure that you have all the tools you will need to properly maintain your vehicle.
- Not all batteries can be used in wet conditions. Consult the battery manufacturer before use. Caution should be taken when using Li-Po batteries in wet conditions.
- Most transmitters are not water-resistant. Consult your transmitter’s manual or the manufacturer before operation.
- Never operate your transmitter or vehicle where lightning may be present.
- Do not operate your vehicle where it could come in contact with salt water (ocean water or water on salt-covered roads), contaminated or polluted water. Salt water is very conductive and highly corrosive, so use caution.
- Even minimal water contact can reduce the life of your motor if it has not been certified as water-resistant or waterproof. If the motor becomes excessively wet, apply very light throttle until the water is mostly removed from the motor. Running a wet motor at high speeds may rapidly damage the motor.

QUICK START

Please read the entire manual to gain a full understanding of the Mini-B vehicle, fine-tuning the setup and performing maintenance.

1. Read the safety precautions found in this manual.
2. Charge the battery. Refer to the included charging warnings and instructions for battery charging information.
3. Install the AAA batteries in the transmitter. Only use alkaline or rechargeable batteries.
4. Install a fully charged battery in the vehicle.
5. Power ON the transmitter and then the vehicle. Always power the transmitter ON before the vehicle and power it OFF after the vehicle has been powered OFF.
6. Check the steering and throttle control directions. Verify that the servos are moving in the correct direction.
7. Drive your vehicle.
8. Perform any necessary maintenance.

- Driving in wet conditions can reduce the life of the motor. The additional resistance of operating in water causes excess strain. Alter the gear ratio by using a smaller pinion or larger spur gear. This will increase torque (and motor life) when running in mud, deeper puddles, or any wet conditions that will increase the load on the motor for an extended period of time.

WET CONDITIONS MAINTENANCE

- Drain any water that has collected in the tires by spinning them at high speed. With the body removed, place the vehicle upside down and pull full throttle for a few short bursts until the water has been removed.

CAUTION: Always keep hands, fingers, tools and any loose or hanging objects away from rotating parts when performing the above drying technique.

- Remove the battery pack(s) and dry the contacts. If you have an air compressor or a can of compressed air, blow out any water that may be inside the recessed connector housing.
- Remove the tires/wheels from the vehicle and gently rinse the mud and dirt off with a garden hose. Avoid rinsing the bearings and transmission.

NOTICE: Never use a pressure washer to clean your vehicle.

- Use an air compressor or a can of compressed air to dry the vehicle and help remove any water that may have gotten into small crevices or corners.
- Spray the bearings, drive train, fasteners and other metal parts with a water-displacing light oil. Do not spray the motor.
- Let the vehicle air dry before you store it. Water (and oil) may continue to drip for a few hours.
- Increase the frequency of disassembly, inspection and lubrication of the following:
 - Front and rear axle hub assembly bearings.
 - All transmission cases, gears and differentials.
 - Motor—clean with an aerosol motor cleaner and re-oil the bushings with lightweight motor oil.

CHARGING WARNINGS

CAUTION: All instructions and warnings must be followed exactly. Mishandling of Li-Po batteries can result in a fire, personal injury and/or property damage.

- **NEVER LEAVE CHARGING BATTERIES UNATTENDED.**
- **NEVER CHARGE BATTERIES OVERNIGHT.**
- By handling, charging or using the included Li-Po battery, you assume all risks associated with lithium batteries.
- If at any time the battery begins to balloon or swell, discontinue use immediately. If charging or discharging, discontinue and disconnect. Continuing to use, charge or discharge a battery that is ballooning or swelling can result in fire.
- Always store the battery at room temperature in a dry area for best results.
- Always transport or temporarily store the battery in a temperature range of 40–120° F (5–49° C).
- Do not store battery or model in a car or direct sunlight. If stored in a hot car, the battery can be damaged or even catch fire.
- Always charge batteries away from flammable materials.

- Always inspect the battery before charging.
- Always disconnect the battery after charging, and let the charger cool between charges.
- Always constantly monitor the temperature of the battery pack while charging.
- **ONLY USE A CHARGER SPECIFICALLY DESIGNED TO CHARGE LI-PO BATTERIES.** Failure to charge the battery with a compatible charger may cause a fire resulting in personal injury and/or property damage.
- Never discharge Li-Po cells to below 3V under load.
- Never cover warning labels with hook and loop strips.
- Never charge batteries outside recommended levels.
- Never charge damaged batteries.
- Never attempt to dismantle or alter the charger.
- Never allow minors to charge battery packs.
- Never charge batteries in extremely hot or cold places (recommended between 40–120° F or [5–49° C]) or place in direct sunlight.

CHARGING THE BATTERY

NOTICE: Charge only batteries that are cool to the touch and are not damaged. Inspect the battery to make sure it is not damaged e.g., swollen, bent, broken or punctured.

CAUTION: Only use chargers specifically designed to charge the included Li-Po battery. Failure to do so could result in fire, causing injury or property damage.

CAUTION: Never exceed the recommended charge rate.

Use only the included USB charger to charge the battery.

1. Connect the charger to a suitable USB power port. The charger will work with most 5V mobile power sources or smartphone chargers with at least 1 amp of power output.

NOTICE: Charging the battery with a USB power port with less than 1 amp of power output can produce heat.

2. Connect the charge lead to the battery, noting correct polarity. Charging a fully discharged battery takes approximately 45–60 minutes. Charge times may vary depending on the power source.

3. Remove the battery from the charger when the charging cycle is complete.
4. Remove the charger from the power supply.

CAUTION: Once charging is complete, immediately remove the battery. Never leave a battery connected to the charger.

Charger LED Indications

RED, solid = Charging
 RED, solid; GREEN, flashing = Stand by
 GREEN, solid = Charging complete

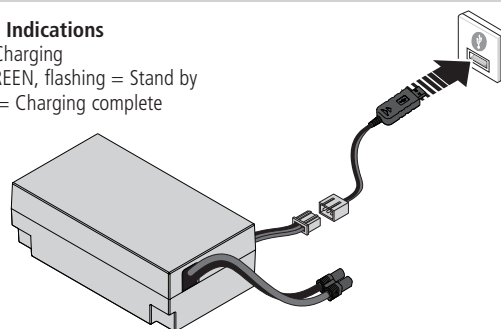

INSTALLING THE BATTERY AND POWERING ON THE VEHICLE

1. Remove the body clips and lift the body.
2. Remove the elastomer strap from the battery posts.
3. Install the fully charged battery in vehicle.
4. Re-secure the elastomer strap.
5. Connect the battery to the ESC/receiver.
6. Ensure the ESC/receiver is powered off.
7. Power on the transmitter.
8. Power on the ESC/receiver.
9. Reinstall the body and the body clips.

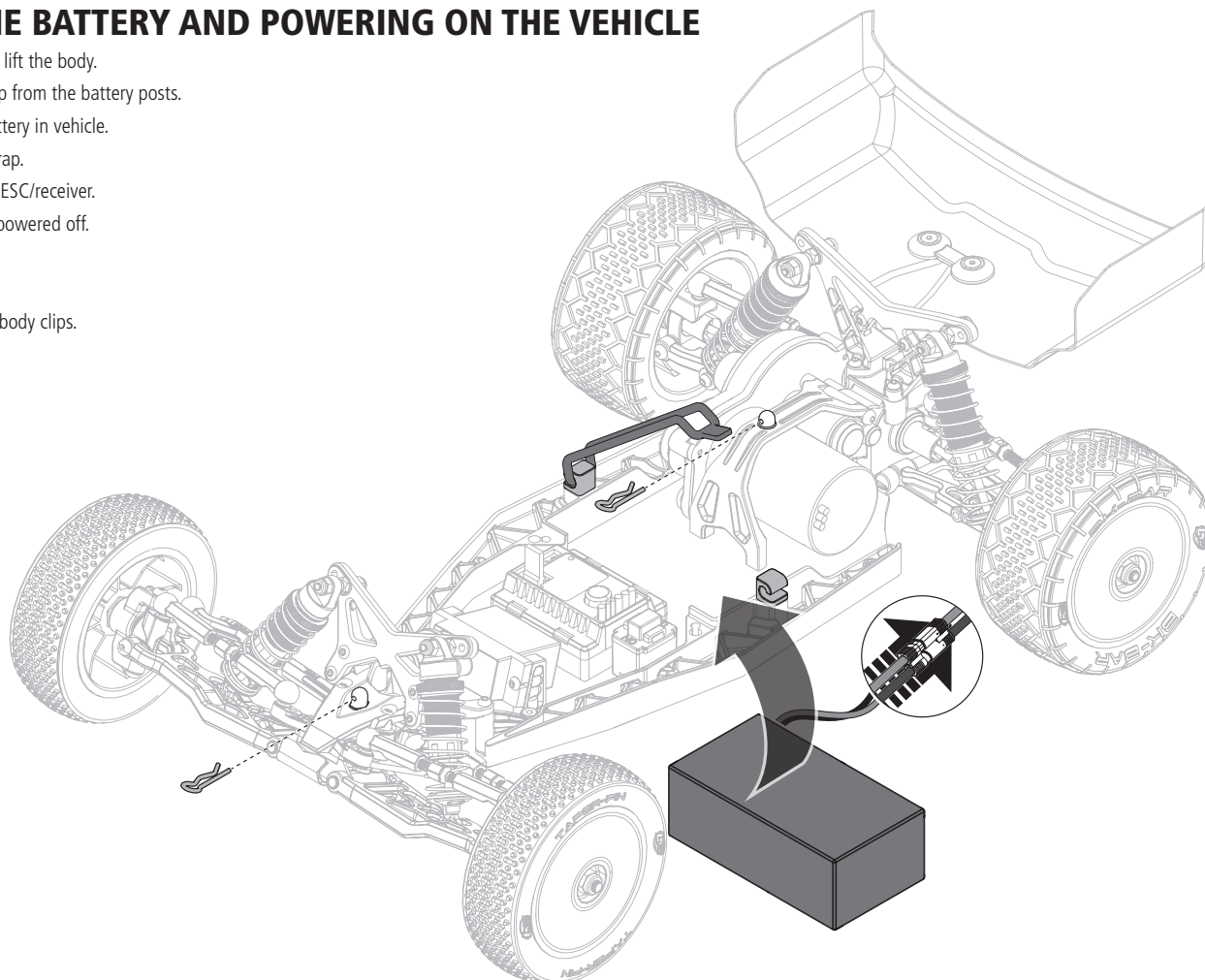

TRANSMITTER

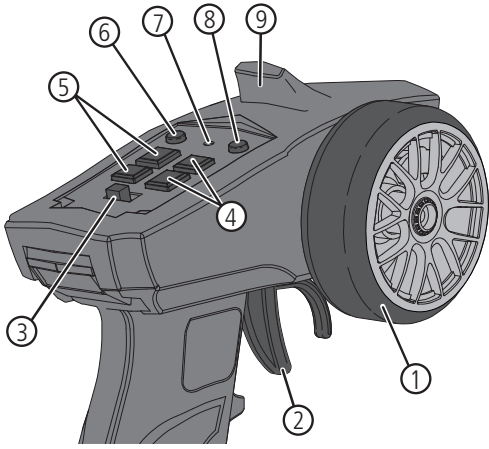

- 1. Steering Wheel** Controls direction (left/right) of the model
- 2. Throttle Trigger** Controls speed and direction (forward/brake/reverse) of the model
- 3. ON/OFF Switch** Turns the power ON/OFF
- 4. Throttle Trim/Dual Rate** Adjusts the throttle trim/end points
- 5. Steering Trim/Dual Rate** Adjusts the steering trim/end points
- 6. CH 3**
- 7. Indicator Lights**
 - **Solid blue light**—Indicates radio connectivity and adequate battery power
 - **Flashing blue light**—Indicates the battery voltage is critically low. Replace batteries
- 8. REV** Reverses the steering wheel and throttle functions
- 9. Antenna** Transmits the signal to the model

ASSEMBLING AND DISASSEMBLING THE TRANSMITTER HANDLE

Assemble

1. On the top transmitter portion, press the rear button.
2. Slide the transmitter handle into the track.

Disassemble

1. On the top transmitter portion, press the rear button.
2. Slide the transmitter handle out of the track.

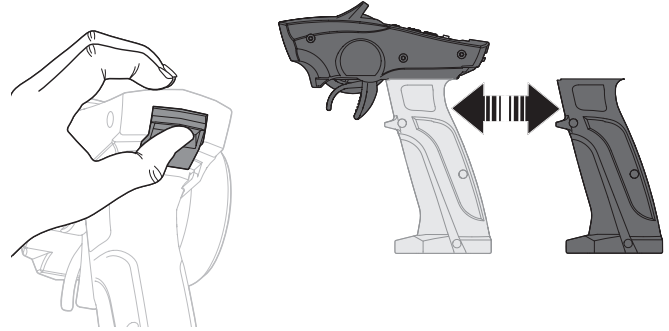

INSTALLING THE TRANSMITTER BATTERIES

This transmitter requires 4 AAA batteries.

1. Remove the battery cover from the transmitter.
2. Install the batteries as shown.
3. Install the battery cover.



CAUTION: If using rechargeable batteries, charge only rechargeable batteries. Charging non-rechargeable batteries may cause the batteries to burst, resulting in injury to persons and/or damage to property.



CAUTION: Risk of explosion if battery is replaced by an incorrect type. Dispose of used batteries according to national regulations.

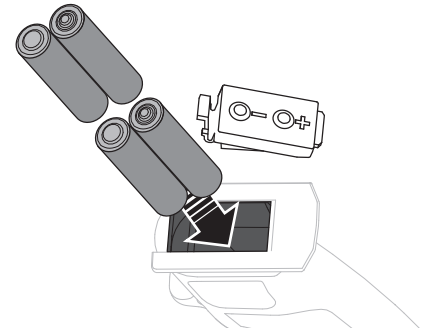

ADJUSTING THE DUAL RATES

The transmitter allows you to adjust steering and throttle dual rates.

Steering Dual Rate

1. Power ON the transmitter.
2. Power ON the vehicle.
3. Turn the steering wheel fully left or right on the transmitter and hold that position.
4. To add or remove steering throw input, continue to hold the steering wheel, and press the (+) or (-) Steering Trim button.

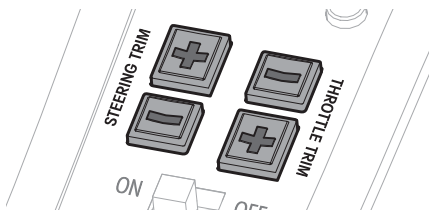

Throttle Dual Rate

1. Place the vehicle on a stand, and power ON the transmitter.
2. Power ON the vehicle.
3. Apply either forward or reverse throttle input on the transmitter and hold that position.
4. To add or remove throttle input, hold the throttle input, and press the (+) or (-) Throttle Trim button.

NOTICE: Do not adjust the throttle dual rate while the vehicle is powered on and the rear wheels are in contact with any surface. Adjusting the throttle dual rate may power the motor, which could cause damage to property or personal injury.

BINDING

Binding is the process of programming the receiver to recognize the GUID (Globally Unique Identifier) code of a single specific transmitter. **The transmitter and ESC/receiver are bound at the factory.** If you need to rebind, follow the instructions below:

1. Connect a fully charged battery to the ESC/receiver.
2. Power on the ESC/receiver.
3. Insert a bind plug into the BIND port of the ESC/receiver and remove it. The ESC/receiver LED flashes, indicating the ESC/receiver is in bind mode.

4. Power ON the transmitter. The ESC/receiver LED turns solid.
5. Power OFF the ESC/receiver to save the settings.
6. Power OFF the transmitter.

You must rebind when binding the ESC/receiver to a different transmitter.

NOTICE: Do not attempt to bind the transmitter and ESC/receiver if there are other compatible transmitters in bind mode within 400 feet. Doing so may result in unexpected binding.

CONTROL TEST

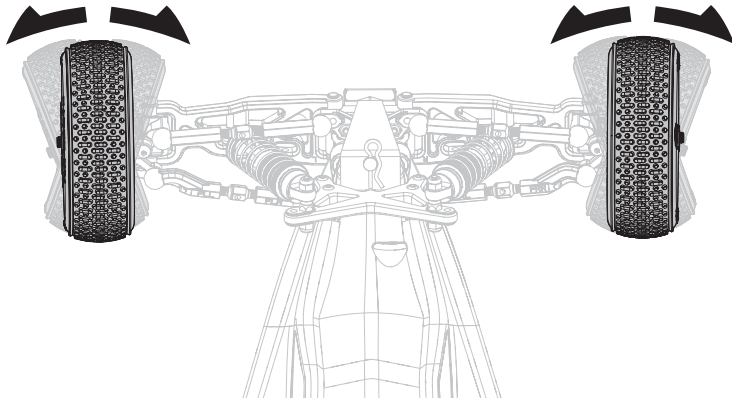

Perform a control test with the vehicle wheels off the ground. If the wheels rotate after the vehicle is powered ON, adjust the Throttle Trim until they stop. To make the wheels move forward, pull the trigger. To reverse them, wait for the wheels to stop, then push the trigger. When moving forward, the wheels should maintain a straight line without any steering wheel input. If not, adjust the Steering Trim, so the wheels maintain a straight line without having to turn the steering wheel.

DRIVING PRECAUTIONS

- Maintain sight of the vehicle at all times.
- Inspect the vehicle for loose wheel hardware.
- Inspect the steering assembly for any loose hardware. Driving the vehicle off-road can cause fasteners to loosen over time.
- Do not drive the vehicle in tall grass. Doing so can damage the vehicle or electronics.
- Stop driving the vehicle when you notice a lack of power. Driving the vehicle when the battery is discharged can cause the receiver to power off. You may lose control of the vehicle.
- Do not apply the throttle in forward or reverse if the vehicle is stuck. Applying throttle in this instance can damage the motor or ESC.
- After driving the vehicle, allow the electronics to cool to ambient temperature before using the next battery pack.

RUN TIME

The condition of a battery pack is also an important factor in both run time and speed. The battery connectors may become hot during driving. Batteries will lose performance and capacity over time.

Driving the vehicle from a stop to full speed repeatedly will damage the batteries and electronics over time. Sudden acceleration will also lead to shorter run times.

TO IMPROVE RUN TIMES

- Keep your vehicle clean and well maintained.
- Allow more airflow to the ESC and motor.
- Change the gearing to a lower ratio. A lower ratio lowers the operating temperature of the electronics. Use a smaller pinion gear or larger spur gear to lower the gear ratio.

GETTING STARTED

1. Power on the transmitter.

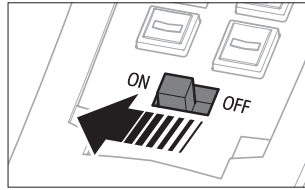

2. Power on the ESC.

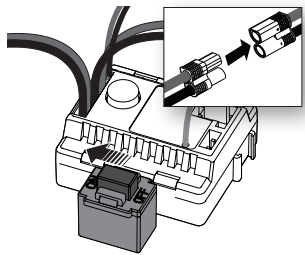

3. Perform a test of the transmitter's control of the vehicle with the vehicle's wheels off the ground.

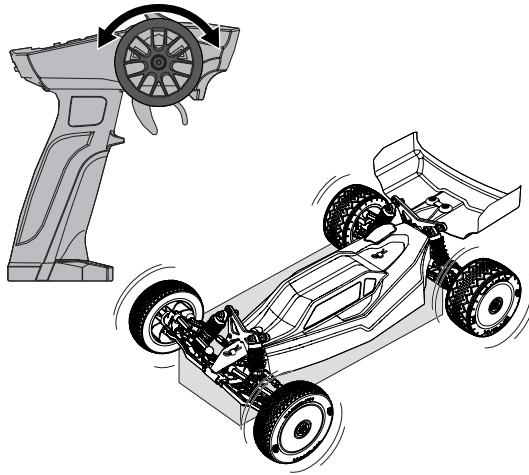

4. Start driving slowly, and, if the vehicle does not go straight, adjust the steering trim dial on the transmitter.

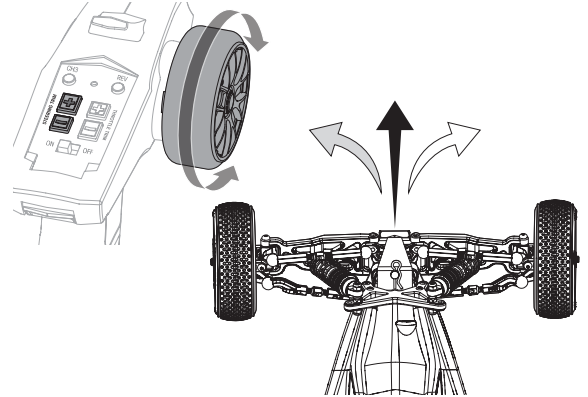

IMPORTANT: Seat the motor brushes by driving smoothly on a flat surface during use of the first battery charge. Properly seating the motor brushes will increase the life and performance of the motor.

OPERATION

- **ALWAYS** turn on your transmitter before you turn on the receiver in the vehicle. Always power off the receiver before turning your transmitter off.
- **ALWAYS** operate your vehicle in a wide open area. Operating the vehicle in a small space or indoors can cause overheating at low speeds. Operating at low speed increases heat in the electronic speed control (ESC). Overheating can damage the vehicle and failure may result.

TUNING, ADJUSTING AND MAINTAINING THE VEHICLE

- Examine your vehicle on a regular basis.
- Use a brush to remove dirt and dust.
- Look for damage to the suspension arms and other molded parts.
- Re-glue the tires to the wheels, if necessary.
- Use suitable tools to tighten fasteners.
- Make sure the camber and steering linkages are not bent. Replace any bent linkages.
- Adjust the Toe and Camber settings, if necessary.
- Remove the shocks and inspect them for damage. Rebuild the shocks if oil is leaking.
- Inspect electronics and batteries for exposed wires. Repair exposed wires with shrink-wrap or replace the wire.
- Make sure the ESC and receiver are secure on the chassis. Replace the double-sided tape, if necessary.
- Power on your transmitter. If the blue light is flashing, replace the AAA batteries in the transmitter.
- Check the spur gear for wear.

SHOCK CLEANING

Oil-filled shocks will require regular maintenance due to the oil breaking down or getting dirty. This maintenance should be performed after about every 3–5 hours of use, depending on the driving conditions.

- Remove the shock from the vehicle.
- Remove the bottom cartridge from the shock body and dispose of fluid.
- Disassemble the shock. Clean thoroughly with a plastic- and electronic-safe degreaser (DYNE50001). Dry parts before assembly.
- Re-assemble the shock and refill the shock body with silicone fluid (22.5 weight recommended, TLR74003).
- Slowly move the shaft and piston up and down to remove air bubbles.
- Move the piston to the midway point of the body and install the bottom cartridge.
- Wipe off any overflowing fluid.
- Re-install the shock on the vehicle.

RIDE HEIGHT ADJUSTMENT

Ride height is an adjustment that affects the way the vehicle jumps, turns and goes over bumps. Drop one end of the vehicle from approximately 6 inches (152 mm) in height onto a flat surface. When dropping the front of the vehicle, after the vehicle settles, make sure the front arms are equal and parallel to the flat surface. Do the same with the rear to make sure both arms are parallel with the flat surface.

Lowering the front ride height increases steering, but decreases traction. Lowering the rear ride height increases traction, but decreases steering.

SERVICE/REPAIR

RADIO/SPEED CONTROL AND MOTOR

If any problems other than those covered in the troubleshooting section arise, please call the appropriate electronics service department. They will be able to give the problem additional specific attention and provide instructions for the solution.

MAINTENANCE

If any questions other than those covered in the troubleshooting or maintenance sections arise, please call the appropriate Horizon product support department.

CLEANING

Performance can be hindered if dirt gets in any of the moving suspension parts. Use compressed air, a soft paintbrush, or a toothbrush to remove dust or dirt. Avoid using solvents or chemicals as they can actually wash dirt into the bearings or moving parts, as well as cause damage to the electronics.

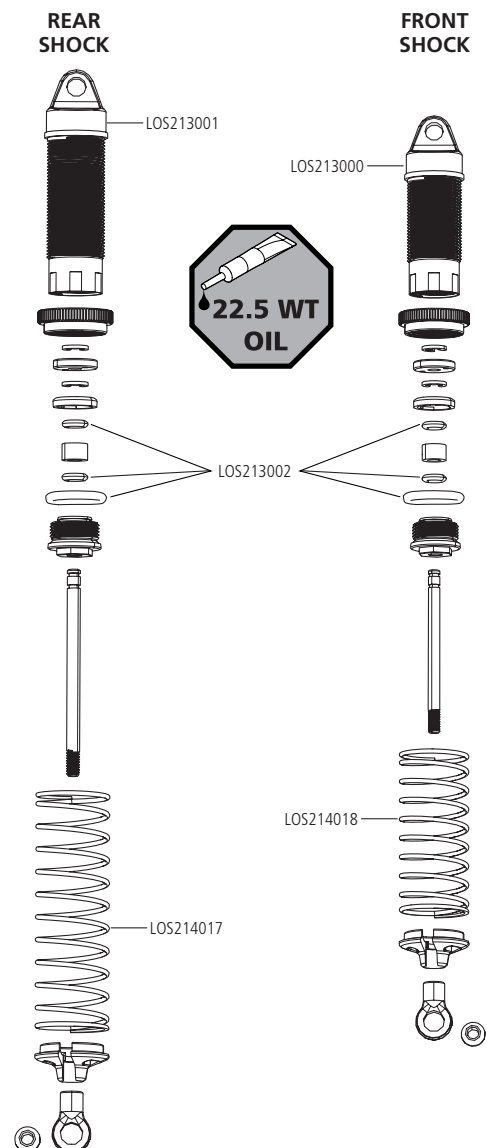

TROUBLESHOOTING GUIDE

PROBLEM	POSSIBLE CAUSE	SOLUTION
Vehicle does not operate	Battery not charged or plugged in	Charge battery/plug in
	ESC switch not "On"	Turn on ESC switch
	Transmitter not "On" or low battery	Turn on/replace batteries
Motor runs but rear wheels do not rotate	Pinion not meshing with spur gear	Adjust pinion/spur mesh
	Pinion spinning on motor shaft	Tighten pinion gear setscrew on motor shaft flat spot
	Transmission gears stripped	Replace transmission gears
	Drive pin broken	Check and replace drive pin
Steering does not work	Servo plug not in receiver properly	Make sure the steering servo plug is connected to the receiver steering channel, noting proper polarity
	Servo gears or motor damaged	Replace or repair servo
Will not turn one direction	Servo gears damaged	Replace or repair servo
Motor does not run	Motor wire solder joint is damaged	Resolder the motor wire with the proper equipment
	Motor wire broken	Repair or replace as needed
	ESC damaged	Contact Horizon Hobby Product Support
ESC gets hot	Motor over-gearred	Use smaller pinion or larger spur gear
	Driveline bound up	Check wheels and transmission for binding
Poor run time and/or sluggish acceleration	Battery pack not fully charged	Recharge battery
	Charger not allowing full charge	Try another charger
	Driveline bound up	Check wheels, transmission for binding
Poor range and/or glitching	Transmitter batteries low	Check and replace
	Vehicle battery low	Recharge battery
	Loose plugs or wires	Check all wire connections and plugs

LIMITED WARRANTY

What this Warranty Covers

Horizon Hobby, LLC, (Horizon) warrants to the original purchaser that the product purchased (the "Product") will be free from defects in materials and workmanship for a period of 2 years from the date of purchase.

What is Not Covered

This warranty is not transferable and does not cover (i) cosmetic damage, (ii) damage due to acts of God, accident, misuse, abuse, negligence, commercial use, or due to improper use, installation, operation or maintenance, (iii) modification of or to any part of the Product, (iv) attempted service by anyone other than a Horizon Hobby authorized service center, (v) Product not purchased from an authorized Horizon dealer, or (vi) Product not compliant with applicable technical regulations or (vii) use that violates any applicable laws, rules, or regulations.

OTHER THAN THE EXPRESS WARRANTY ABOVE, HORIZON MAKES NO OTHER WARRANTY OR REPRESENTATION, AND HEREBY DISCLAIMS ANY AND ALL IMPLIED WARRANTIES, INCLUDING, WITHOUT LIMITATION, THE IMPLIED WARRANTIES OF NON-INFRINGEMENT, MERCHANTABILITY AND FITNESS FOR A PARTICULAR PURPOSE. THE PURCHASER ACKNOWLEDGES THAT THEY ALONE HAVE DETERMINED THAT THE PRODUCT WILL SUITABLY MEET THE REQUIREMENTS OF THE PURCHASER'S INTENDED USE.

Purchaser's Remedy

Horizon's sole obligation and purchaser's sole and exclusive remedy shall be that Horizon will, at its option, either (i) service, or (ii) replace, any Product determined by Horizon to be defective. Horizon reserves the right to inspect any and all Product(s) involved in a warranty claim. Service or replacement decisions are at the sole discretion of Horizon. Proof of purchase is required for all warranty claims. SERVICE OR REPLACEMENT AS PROVIDED UNDER THIS WARRANTY IS THE PURCHASER'S SOLE AND EXCLUSIVE REMEDY.

Limitation of Liability

HORIZON SHALL NOT BE LIABLE FOR SPECIAL, INDIRECT, INCIDENTAL OR CONSEQUENTIAL DAMAGES, LOSS OF PROFITS OR PRODUCTION OR COMMERCIAL LOSS IN ANY WAY, REGARDLESS OF WHETHER SUCH CLAIM IS BASED IN CONTRACT, WARRANTY, TORT, NEGLIGENCE, STRICT LIABILITY OR ANY OTHER THEORY OF LIABILITY, EVEN IF HORIZON HAS BEEN ADVISED OF THE POSSIBILITY OF SUCH DAMAGES. Further, in no event shall the liability of Horizon exceed the individual price of the Product on which liability is asserted. As Horizon has no control over use, setup, final assembly, modification or misuse, no liability shall be assumed nor accepted for any resulting damage or injury. By the act of use, setup or assembly, the user accepts all resulting liability. If you as the purchaser or user are not prepared to accept the liability associated with the use of the Product, purchaser is advised to return the Product immediately in new and unused condition to the place of purchase.

Law

These terms are governed by Illinois law (without regard to conflict of law principals). This warranty gives you specific legal rights, and you may also have other rights which vary from state to state. Horizon reserves the right to change or modify this warranty at any time without notice.

WARRANTY SERVICES

Questions, Assistance, and Services

Your local hobby store and/or place of purchase cannot provide warranty support or service. Once assembly, setup or use of the Product has been started, you must contact your local distributor or Horizon directly. This will enable Horizon to better answer your questions and service you in the event that you may need any assistance. For questions or assistance, please visit our website at www.horizonhobby.com, submit a Product Support Inquiry, or call the toll free telephone number referenced in the Warranty and Service Contact Information section to speak with a Product Support representative.

Inspection or Services

If this Product needs to be inspected or serviced and is compliant in the country you live and use the Product in, please use the Horizon Online Service Request submission process found on our website or call Horizon to obtain a Return Merchandise Authorization (RMA) number. Pack the Product securely using a shipping carton. Please note that original boxes may be included, but are not designed to withstand the rigors of shipping without additional protection. Ship via a carrier that provides tracking and insurance for lost or damaged parcels, as Horizon is not responsible for merchandise until it arrives and is accepted at our facility. An Online Service Request is available at http://www.horizonhobby.com/content/service-center_render-service-center. If you do not have internet access, please contact Horizon Product Support to obtain a RMA number along with instructions for submitting your product for service. When calling Horizon, you will be asked to provide your complete name, street address, email address and phone number where you can be reached during business hours. When sending product into Horizon, please include your RMA number, a list of the included items, and a brief summary of the problem. A copy of your original sales receipt must be included for warranty consideration. Be sure your name, address, and RMA number are clearly written on the outside of the shipping carton.

NOTICE: Do not ship Li-Po batteries to Horizon. If you have any issue with a Li-Po battery, please contact the appropriate Horizon Product Support office.

Warranty Requirements

For Warranty consideration, you must include your original sales receipt verifying the proof-of-purchase date. Provided warranty conditions have been met, your Product will be serviced or replaced free of charge. Service or replacement decisions are at the sole discretion of Horizon.

Non-Warranty Service

Should your service not be covered by warranty, service will be completed and payment will be required without notification or estimate of the expense unless the expense exceeds 50% of the retail purchase cost. By submitting the item for service you are agreeing to payment of the service without notification. Service estimates are available upon request. You must include this request with your item submitted for service. Non-warranty service estimates will be billed a minimum of ½ hour of labor. In addition you will be billed for return freight. Horizon accepts money orders and cashier's checks, as well as Visa, MasterCard, American Express, and Discover cards. By submitting any item to Horizon for service, you are agreeing to Horizon's Terms and Conditions found on our website http://www.horizonhobby.com/content/service-center_render-service-center.



ATTENTION: Horizon service is limited to Product compliant in the country of use and ownership. If received, a non-compliant Product will not be serviced. Further, the sender will be responsible for arranging return shipment of the un-serviced Product, through a carrier of the sender's choice and at the sender's expense. Horizon will hold non-compliant Product for a period of 60 days from notification, after which it will be discarded.

WARRANTY AND SERVICE CONTACT INFORMATION

COUNTRY OF PURCHASE	HORIZON HOBBY	CONTACT INFORMATION	ADDRESS
United States of America	Horizon Service Center (Repairs and Repair Requests)	servicecenter.horizonhobby.com/RequestForm/	2904 Research Rd Champaign, Illinois, 61822 USA
	Horizon Product Support (Product Technical Assistance)	productsupport@horizonhobby.com 877-504-0233	
	Sales	websales@horizonhobby.com 888-338-4639	
EU	Horizon Technischer Service Sales: Horizon Hobby GmbH	service@horizonhobby.eu +49 (0) 4121 2655 100	Hanskampring 9 D 22885 Barsbüttel, Germany

FCC INFORMATION

FCC ID: 2ARE7-91803

Supplier's Declaration of Conformity LOS Mini-B RTR: 1/16th Scale 2WD Buggy (LOS01016)

This device complies with part 15 of the FCC Rules. Operation is subject to the following two conditions: (1) This device may not cause harmful interference, and (2) this device must accept any interference received, including interference that may cause undesired operation.



CAUTION: Changes or modifications not expressly approved by the party responsible for compliance could void the user's authority to operate the equipment.

NOTE: This equipment has been tested and found to comply with the limits for a Class B digital device, pursuant to part 15 of the FCC Rules. These limits are designed to provide reasonable protection against harmful interference in a residential installation. This equipment generates, uses and can radiate radio frequency energy and, if not installed and used in accordance with the instructions, may cause harmful interference to radio communications. However, there is

no guarantee that interference will not occur in a particular installation. If this equipment does cause harmful interference to radio or television reception, which can be determined by turning the equipment off and on, the user is encouraged to try to correct the interference by one or more of the following measures:

- Reorient or relocate the receiving antenna.
- Increase the separation between the equipment and receiver.
- Connect the equipment into an outlet on a circuit different from that to which the receiver is connected.
- Consult the dealer or an experienced radio/TV technician for help.

Horizon Hobby, LLC
2904 Research Rd.,
Champaign, IL 61822
Email: compliance@horizonhobby.com
Web: HorizonHobby.com

IC INFORMATION

CAN ICES-3 (B)/NMB-3(B)

IC: 20264-91803RX46

This device contains license-exempt transmitter(s)/receiver(s) that comply with Innovation, Science, and Economic Development Canada's license-exempt RSS(s). Operation is subject to the following 2 conditions:

1. This device may not cause interference.
2. This device must accept any interference, including interference that may cause undesired operation of the device.

COMPLIANCE INFORMATION FOR THE EUROPEAN UNION



EU Compliance Statement:

Hereby, Horizon Hobby, LLC declares that the device is in compliance with the following: EU Radio Equipment Directive 2014/53/EU.

The full text of the EU declaration of conformity is available at the following internet address: <https://www.horizonhobby.com/content/support-render-compliance>.

Wireless Frequency Range and Wireless Output Power:

2405–2478MHz
8dBm



E328

EU Manufacturer of Record:

Horizon Hobby, LLC
2904 Research Road
Champaign, IL 61822 USA

EU Importer of Record:

Horizon Hobby, GmbH
Hanskampring 9
22885 Barsbüttel Germany

WEEE NOTICE:



This appliance is labeled in accordance with European Directive 2012/19/EU concerning waste of electrical and electronic equipment (WEEE). This label indicates that this product should not be disposed of with household waste. It should be deposited at an appropriate facility to enable recovery and recycling.

PARTS LISTINGS | TEILELISTE | LISTE DES PIÈCES | ELENCO COMPONENTI

PART #	ENGLISH	DEUTSCH	FRANÇAIS	ITALIANO
DYNB65021H2	650 mAh, 2S, 7.4V, 20C, LiPo	650 mAh, 2S, 7,4 V, 20C, LiPo	LiPo 650 mAh, 2S, 7,4 V, 20C	650 mAh, 2S, 7,4V, 20C, LiPo
DYN51218	Dynamite 47T 280 BD Motor: Mini-T 2.0	Dynamite 47T 280 Bürstenmotor: Mini-T 2.0	Moteur à balais Dynamite 47T 280	Motore Dynamite 47T 280 BD
HRZ00001	Horizon 3-CH 2.4GHz Surface Transmitter	Horizon 2,4 GHz Oberflächensender mit 3 Kanälen	Émetteur de surface 3 canaux 2,4 GHz Horizon	Trasmittente di superficie Horizon 3 canali 2,4 GHz
HRZ00002	Horizon ESC/Receiver, 2.4GHz	Horizon Geschwindigkeitsregler/Empfänger 2,4 GHz	ESC/Rx Horizon 2,4 GHz	ESC/Ricevitore Horizon 2,4 GHz
LOS210019	Body, Wing, Blue/White	Karosserie, Tragfläche, blau/weiß	Coque, aile, bleue/blanche	Carrozzeria, alettone, bianco/blu
LOS210020	Body, Wing, Black/White	Karosserie, Tragfläche, schwarz/weiß	Coque, aile, noire/blanche	Carrozzeria, alettone, bianco/nero
LOS210022	Wing, Precut, Clear (2)	Tragfläche, Gehäuse, farblos (2)	Aile, prédécoupée, transparente (2)	Alettone, pretagliato, trasparente (2)
LOS210023	Body, Wing, Yellow/White	Karosserie, Tragfläche, gelb/weiß	Coque, aile, jaune/blanche	Carrozzeria, alettone, bianco/giallo
LOS211011	Front Bulkhead, Front Brace, Left/Right	Vordere Spritzwand, Strebe links/rechts	Cloison avant, support gauche/droite	Paratia anteriore, montante SX/DX
LOS211012	Servo Mount, Servo Saver	Servohalterung, Servo-Saver	Support de servo, économiseur de servo	Supporto servo, salvaservo
LOS211013	Bellcrank, Drag Link, Set	Umlenkhebel, Lenkzwischenstangensatz	Levier coudé, ensemble barre de direction	Set tirante longitudinale, squadretta
LOS211016	Gear Cover with Plug	Getriebeabdeckung mit Stecker	Cache d'engrenage avec bouchon	Carter ingranaggi con tappo
LOS211020	Chassis & Mud Guards	Chassis und Schmutzfänger	Châssis et garde-boues	Parafanghi e parataliaio
LOS211021	Waterfall, Front Body Post	Kaskade, Vordere Gehäusestange	Waterfall, montant de coque avant	Waterfall, supporto carrozzeria ant.
LOS211022	Battery Strap, Elastomer	Akku-Klemme, Elastomer	Dispositif de maintien de batterie, élastomère	Fascetta batteria, elastomero
LOS212011	Wheel Hex, Pin (2)	Sechskanrad, Stift (2)	Écrou hexagonal de roue, axe (2)	Esagono ruota, perno (2)
LOS212012	Rear Axle (2)	Hinterachse (2)	Axe arrière (2)	Assale posteriore (2)
LOS212013	Dogbone (2)	Dogbone (2)	Dogbone (2)	Cardano (2)
LOS212014	Front Axle (2)	Vorderachse (2)	Axe avant (2)	Assale anteriore (2)
LOS212015	Slipper Hardware	Gleiter-Hardware	Accessoires de sabot	Parti antisaltellamento
LOS212016	Spur Gear with Slipper Pads 60T 0.5M	Stirnrad mit Gleitkissen 60T 0.5M	Roue droite cylindrique avec sabots de piston, 60T 0,5 M	Ingr. cilindrico con pattini di scorr. 60T 0,5 M
LOS212018	Differential Gear, Idler Gear	Differentialgetriebe, Zwischenrad	Engrenage différentiel, pignon intermédiaire	Differenziale, ruota folle
LOS212019	Outdrive Sun Spider Gear Set	Sonnen-/Planetenradantriebssatz	Arbre extérieur, roue solaire/pignon satellite, ensemble	Kit outdrive, satellite/planetario
LOS212020	Top Shaft	Obere Welle	Arbre supérieur	Albero superiore
LOS212021	Transmission Case & Motor Plate	Getriebeabdeckung und Motorplatte	Plaque moteur et boîtier de transmission	Piastra motore e scatola di trasmissione
LOS212022	Losi .5 Mod Pinion Gear, 18T, 2mm	Losi .5 Mod Zahnradgetriebe, 18T, 2mm	Pignon mod. 0,5 Losi, 18T, 2 mm	Pignone Losi .5 Mod, 18T, 2 mm
LOS213000	Front Shock Set Complete	Kompletter vorderer Stoßdämpfersatz	Lot d'amortisseurs avant, complet	Set completo ammortizzatore anteriore
LOS213001	Rear Shock Set Complete	Kompletter hinterer Stoßdämpfersatz	Lot d'amortisseurs arrière, complet	Set completo ammortizzatore posteriore
LOS213002	Shock O-Ring Set	O-Ring-Satz für den Stoßdämpfer	Ensemble joint torique d'amortisseur	Kit O-ring ammortizzatore
LOS214003	Suspension Arm Set, Front/Rear	Aufhängungsarmsatz, vorn/hinten	Lot de bras de suspension, avant/arrière	Set braccetti sospensioni, ant./post.
LOS214005	Caster Block & Front Camber Block	Radblock & Vorderer Radsturzblock	Bloc de roulettes et cale de carrossage avant	Set blocchi incidenza e campanatura ant.
LOS214006	Spindle & Hub Set	Spindel- und Nabensatz	Ensemble axe et moyeu	Set mozzo e fusello
LOS214008	Shock Standoff Bushing	Kappen Stoßdämpfer-Standoff	Bague entretoise d'amortisseur	Boccola distanziale ammortizzatore
LOS214009	Rear Pivots & Bumper	Hintere Drehgelenke und Stoßstange	Pare-chocs et pivots arrière	Pivot posteriori e paraurti
LOS214010	Front Pivot & Bumper	Vorderes Drehgelenk und Stoßstange	Pare-chocs et pivot avant	Pivot anteriore e paraurti
LOS214012	Front/Rear Shock Tower, Wing Stay	Vordere/hintere Stoßdämpferbrücke, Kotflügelstütze	Tour d'amortisseur avant/arrière, dispositif de maintien d'aile	Supp. amm. ant./post., supp. alettone
LOS214013	Adjustable Link Set	Anpassbarer Verbindungssatz	Ensemble de liaisons ajustables	Set leveraggio regolabile
LOS214014	Rear Shock Springs (3 pair)	Hintere Stoßdämpferfedern (3)	Ressorts d'amortisseur arrière (3)	Molle ammortizzatori posteriori (3)
LOS214015	Front Shock Springs (3 pair)	Vordere Stoßdämpferfedern (3)	Ressorts d'amortisseur avant (3)	Molle ammortizzatori anteriori (3)
LOS214016	Rod End Set	Stangenkopfsatz	Ensemble d'embout de bielle	Kit teste a snodo
LOS214017	Rear Shock Springs (3pr)	Hintere Stoßdämpferfedern (3pr)	Ressorts d'amortisseur arrière (3 paires)	Molle amm. post. (3 pr)
LOS214018	Front Shock Springs (3pr)	Vordere Stoßdämpferfedern (3pr)	Ressorts d'amortisseur avant (3 paires)	Molle amm. ant.(3 pr)
LOS216002	Ball Stud (4)	Kugelzapfen (4)	Pivot à rotule (4)	Prigioniero a sfera (4)
LOS216003	Screw Set, Button Head	Schraubensatz, Rundkopf	Ensemble de vis, tête bombée	Set viti a testa tonda
LOS216004	Screw Set, Flat Head	Schraubensatz, Flachkopf	Ensemble de vis, tête plate	Set viti a testa piatta
LOS216005	King Pin Set	Sattelzapfensatz	Ensemble axe de pivotement	Set perni di fuso

PART #	ENGLISH	DEUTSCH	FRANÇAIS	ITALIANO
LOS217001	4 x 7 x 2.5mm Ball Bearing (4)	4 x 7 x 2,5 mm Kugellager (4)	Roulement à billes 4 x 7 x 2,5 mm (4)	Cuscinetti a sfera 4x7x2,5 mm (4)
LOS214016	Rod End Set	Stangenkopfsatz	Ensemble d'embout de bielle	Kit teste a snodo
LOS214017	Rear Shock Springs (3pr)	Hintere Stoßdämpferfedern (3pr)	Ressorts d'amortisseur arrière (3 paires)	Molle amm. post. (3 pr)
LOS214018	Front Shock Springs (3pr)	Vordere Stoßdämpferfedern (3pr)	Ressorts d'amortisseur avant (3 paires)	Molle amm. ant.(3 pr)
LOS41018	BK Bar, Rear Mounted, White (2)	BK-Stange, innen befestigt, weiß (2)	Barre BK, montée à l'arrière, blanche (2)	BK Bar, montaggio posteriore, bianco (2)
SPMSSX107	SX107 Micro Metal Gear Servo	BK-Stange, innen befestigt, weiß (2)	Micro servo à engrenage métallique SX107	Micro servo con ingranaggi in metallo SX107

OPTIONAL PARTS | OPTIONALE BAUTEILE | PIÈCES OPTIONNELLES | PEZZI OPZIONALI

PART #	ENGLISH	DEUTSCH	FRANÇAIS	ITALIANO
DYNC2030	Prophet Sport Mini 50W Charger	Prophet Sport Mini 50 W Ladegerät	Chargeur 50 W Prophet Sport Mini	Caricabatterie Prophet Sport Mini 50 W
DYNT2010	Machined Nut Driver Set (4), Metric	Set gefräste Steckschlüssel (4), metrisch	Ensemble de tournevis à écrou usiné (4), métrique	Set di chiavi per dadi lavorate (4), metrico
DYNB825H2	7.4V 800mAh 2S 50C Hardcase LiPo	7.4V 800mAh 2S 50C Hartschale LiPo	Li-Po boîtier rigide 50C 2S 800 mAh 7,4 V	Batteria 7,4 V 800 mAh 2S 50C Hardcase Li-Po
DYNC0095	Adapter: EC2 Device/Banana Plug	Adapter: Adapter EC2-Gerät/ Bananen-Stecker	Adaptateur : dispositif EC2/fiche banane	Adattatore: dispositivo EC2/spina a banana
DYNS0501	Brushless Motor/ESC Combo: 6000Kv	Bürstenloser Motor/Combo-Geschwindig- keitsregler: 6000kv	Combinaison moteur sans balais/ESC : 6000 Kv	Combo motore Brushless/ESC: 6000 Kv
LOS41011	Front/Rear Wheel, Yellow	Vorder-/Hinterrad, gelb	Roue avant/arrière, jaune	Ruota ant./post., gialla
LOS41012	Front/Rear Wheel, White	Vorder-/Hinterrad, weiß	Roue avant/arrière, blanche	Ruota ant./post., bianca
LOS210021	Body, Wing, Clear	Gehäuse, Tragfläche, farblos	Coque, aile, transparente	Carrozzeria, alettone, trasparente
LOS216001	Body Clips (6)	Gehäuseklappen (6)	Clips de carrosserie (6)	Clip carrozzeria (6)
LOS311001	Front Pivot, Aluminum	Vorderes Drehgelenk, Aluminium	Pivot avant, aluminium	Pivot anteriore, alluminio
LOS311002	Bellcrank Drag Link Aluminum	Umlenkhebel, Lenkzwischenstange Aluminium	Levier coudé barre de direction aluminium	Tirante squadretta alluminio
LOS311003	Caster Black, 0 Deg, L/R, Aluminum	Nachlauf schwarz, 0 Grad, links/rechts, Aluminium	Roulette noire, 0deg., gauche/droite, aluminium	Caster block, 0°, SX/DX, alluminio
LOS311005	Hub Set, Rear, Aluminum	Nabensatz, hinten, Aluminium	Ensemble moyeu, arrière, aluminium	Set mozzo, posteriore, alluminio
LOS311006	Pivot Block Set, Rear, Aluminum	Drehgelenksatz schwarz, hinten, Aluminium	Ensemble pivot noir, arrière, aluminium	Set pivot nero, posteriore, alluminio
LOS311007	Front Brace Set, Aluminum	Frontstrebenatz, Aluminium	Ensemble support avant, aluminium	Set bretella anteriore, alluminio
LOS311008	Servo Mount Set, Aluminum	Servohalterungssatz, Aluminium	Ensemble support de servo, aluminium	Set supporto servo, alluminio
LOS311009	Camber Black, Front, Aluminum	Radsturz schwarz, vorn, Aluminium	Carrossage noir, avant, aluminium	Blocco camber, anteriore, alluminio
LOS311010	Servo Arm, Aluminum	Servoarm, Aluminium	Bras de servo, aluminium	Squadretta servo, alluminio
LOS312004	Hex Set, Rear Axle, Aluminum	Sechskantsatz, Hinterachse, Aluminium	Ensemble écrou hexagonal, axe arrière, aluminium	Set hex, assale posteriore, alluminio
LOS312005	Adjustable Motor Plate	Verstellbare Motorplatte	Plaque de moteur ajustable	Piastra motore regolabile
LOS312007	Slipper Plate, HD	Gleiterplatte, HD	Plaque du sabot, ultrarésistante	Piastra di scorrimento, HD
LOS314004	Shock Assembly, Front, Aluminum (2)	Stoßdämpferbaugruppe, vorn, Aluminium (2)	Ensemble amortisseur, avant, aluminium (2)	Gruppo ammortizzatori, alluminio, anteriore (2)
LOS314005	Shock Assembly, Rear, Aluminum (2)	Stoßdämpferbaugruppe, hinten, Aluminium (2)	Ensemble amortisseur, arrière, aluminium (2)	Gruppo ammortizzatori, alluminio, posteriore (2)

EXPLODED VIEW | EXPLOSIONSZEICHNUNG | VUE ÉCLATÉE DES PIÈCES | VISTA ESPLOSA DELLE PARTI

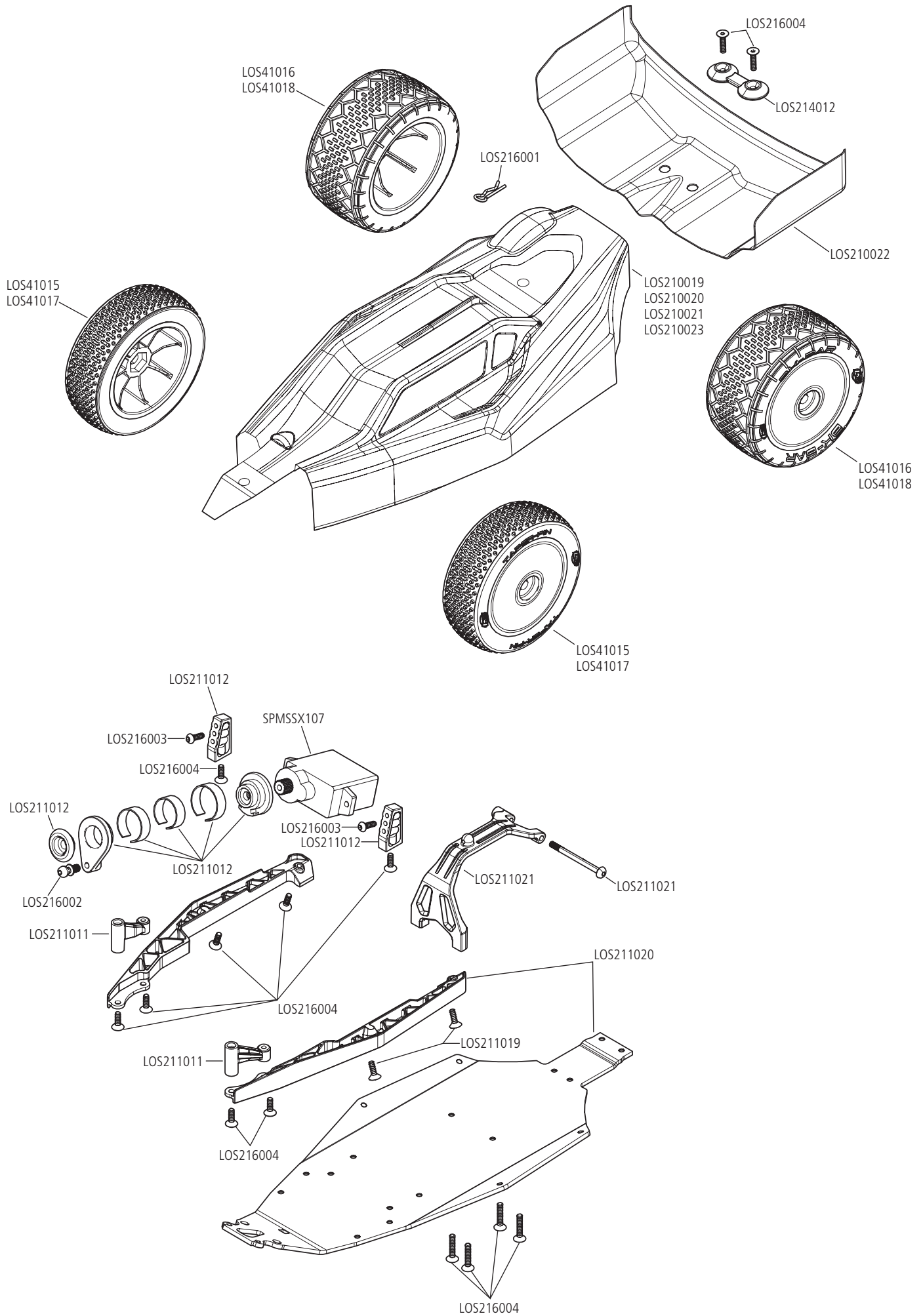

EXPLODED VIEW | EXPLOSIONSZEICHNUNG | VUE ÉCLATÉE DES PIÈCES | VISTA ESPLOSA DELLE PARTI

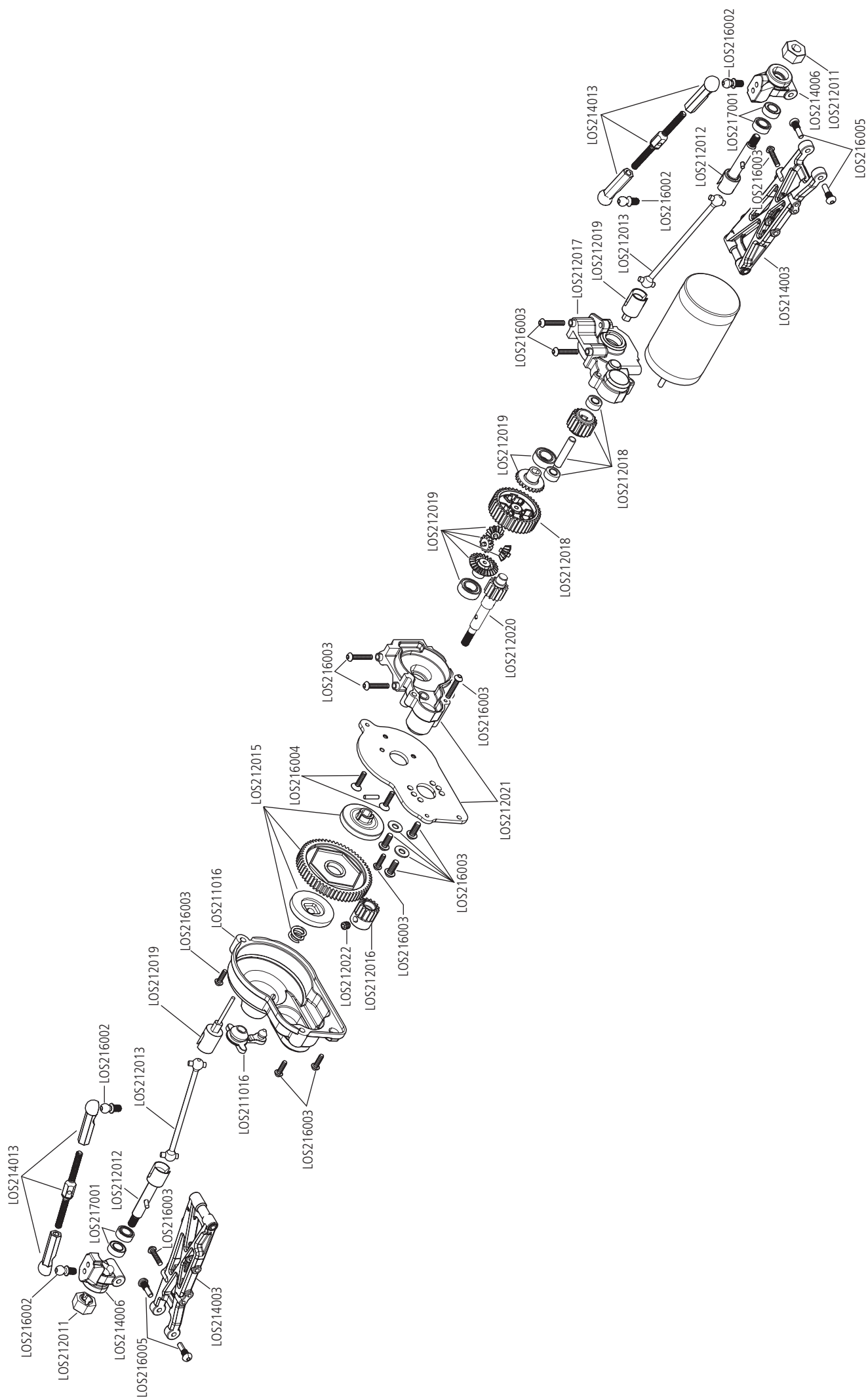

EXPLODED VIEW | EXPLOSIONSZEICHNUNG | VUE ÉCLATÉE DES PIÈCES | VISTA ESPLOSA DELLE PARTI

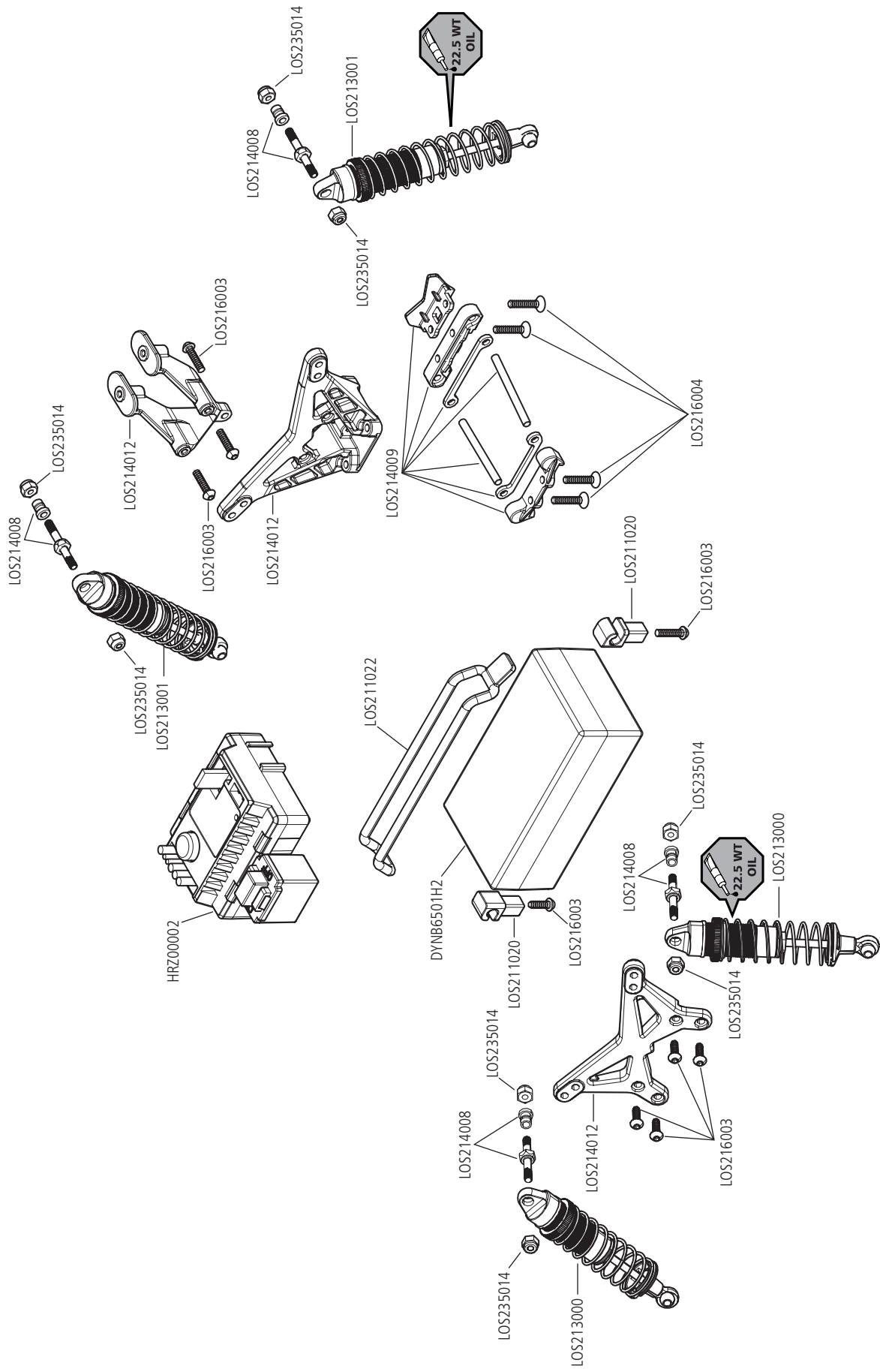



WWW.LOSI.COM

63791

Created 08/2020 | LOS01016

©2020 Horizon Hobby, LLC.

Losi, Mini-B, Dynamite, EC2, and the Horizon Hobby logo are trademarks or registered trademarks of Horizon Hobby, LLC.

The Spektrum trademark is used with permission of Bachmann Industries, Inc. All other trademarks, service marks and logos are property of their respective owners.